



---

# WHAT'S INSIDE MATTERS<sup>®</sup>

---

SPRING 2014 CATALOG





**WHAT'S INSIDE MATTERS®**

There's something in our DNA and in our collective consciousness. It's in our walls, halls, workers, and machines. It makes us different from everyone else out there. It has for over 100 years. And will, for the next 100.

To some, it might look like we're fixated, obsessed. And we'll own up to that. Because all of that focus, the repetition, the tinkering, testing, and what looks like head-banging-against-the-wall – that's what it looks like when you're going after something big.

And when it comes to chasing down dependability, we just can't help ourselves. It's what we've done for years. It inspired us way back when and it inspires us now.

**It's what we're made of.**



# AMERICAN Pride

## From our backyard to your front door

At the core of every American home are appliances that bring special occasions to life and keep everyday events running smoothly. So when you hear that Maytag brand offers products designed, engineered and assembled in the U.S.A., it means our employees get it. Because when they aren't using appliances, they're creating them.



# AMERICAN HIDDEN

**Amana, Iowa**

*Manufacturing and technology center*

**Benton Harbor, Michigan**

*World headquarters*

**Cleveland, Tennessee**

*Manufacturing and technology center*

**Clyde, Ohio**

*Manufacturing*

**Findlay, Ohio**

*Manufacturing*

**Greenville, Ohio**

*Manufacturing*

**Marion, Ohio**

*Manufacturing*

**Ottawa, Ohio**

*Manufacturing*

**Tulsa, Oklahoma**

*Manufacturing*



# PINNACLE OF DEPENDABILITY

Recreating secret family recipes, keeping superhero blanket capes ready for action and serving holiday dinners on grandma's china. Your family depends on you, and that's why you trust us with the truly important things. We build our appliances with durable parts that stand up to all of life's adventures, and we back them up with our best warranties.

With Maytag brand in your home, you're free to focus on what really counts.



Visit [maytag.com](http://maytag.com) for warranty details. Parts vary by model.

## LAUNDRY

- 10** Maxima XL™ High-Efficiency Front Load Laundry Pairs
- 16** Maxima X™ High-Efficiency Front Load Laundry Pairs
- 22** Bravos XL® High-Efficiency Top Load Laundry Pairs
- 28** Bravos X® High-Efficiency Top Load Laundry Pairs
- 34** Centennial® Top Load Laundry Pairs

## REFRIGERATION

- 52** French Door Refrigerators
- 60** Bottom-Freezer Refrigerators
- 64** Side-by-Side Refrigerators
- 68** Top-Freezer Refrigerators
- 74** Specialty Refrigeration

## DISHWASHERS

- 86** Fully Integrated Control Dishwashers
- 88** Traditional Control Dishwashers

## COOKING

- 96** Gemini® Double Oven Ranges
- 102** Freestanding Ranges
- 108** Microwaves
- 114** Wall Ovens
- 122** Cooktops
- 132** Kitchen Ventilation

## ACCESSORIES

- 146** Laundry Accessories
- 148** Refrigeration Accessories
- 150** Dishwasher Accessories
- 152** Cooking Accessories





# BEST CLEANING IN THE INDUSTRY ENABLED BY THE POWERWASH® CYCLE\*

MAYTAG® WASHERS PUT EVEN YOUR WORST STAINS THROUGH THE WRINGER

\*For Bravos XL® washer models MVWB980B and MVWB880B, among leading top load brands, comparable cycles and default settings. For Maxima XL™ washer models MHW6000A, MHW7000A and MHW8000A, among leading front load brands, comparable cycles and settings.



**NEW**

Maxima XL™ High-Efficiency  
Front Load Laundry Pairs

**10**



**NEW**

Maxima X™ High-Efficiency  
Front Load Laundry Pairs

**16**



**NEW**

Bravos XL® High-Efficiency  
Top Load Laundry Pairs

**22**



**NEW**

Bravos X® High-Efficiency  
Top Load Laundry Pairs

**28**



**NEW**

Centennial® Top Load  
Laundry Pairs

**34**

1



2





## PowerWash<sup>®</sup> system

# BEST CLEANING IN THE INDUSTRY\*

Your wardrobe is an expression of you. That's why select washers come fully equipped with the PowerWash<sup>®</sup> system to make sure you have the Best Cleaning in the industry\* at your side, load after load.

# 1

### PowerSpray technology

Water and detergent are sprayed directly onto clothes early in the cycle for enhanced cleaning. This unique technology delivers enhanced cleaning performance by ensuring that detergent is evenly distributed throughout the load.

# 2

### Optimal dispensing

Maytag brand optimal dispensers provide enhanced cleaning performance. The dispensers release detergent and other additives at the right time for better cleaning.

# 3

### PowerWash<sup>®</sup> cycle

The PowerWash<sup>®</sup> cycle uses a combination of extra cleaning action and a thorough rinse to help remove even your toughest stains and deliver the Best Cleaning in the industry.\*

Note: Not all features are available on all models.  
Models shown: MHW8000AG & MVWB980BG. Maxima XL™ washer shown with 15.5" pedestal, model XHPC155XG.  
\*For Bravos XL™ washer models MVWB980B and MVWB880B, among leading top load brands, comparable cycles and default settings. For Maxima XL™ washers: among leading front load brands, comparable cycles and settings.



# Maxima XL™

High-Efficiency Front Load Laundry Pairs

Models shown: MHW8000AG & ME/GD8000AG  
Shown with 15.5" pedestals, model XHPC155XG



**Best Cleaning in the Industry\***

Get the Best Cleaning in the industry\*—in hot or cold water. The PowerWash® cycle delivers the best hot water cleaning while the Cold Wash cycle is the best in cold. Whether it's hot or cold, you can give your clothes the best cleaning\* with a Maxima XL™ washer.



**Overnight Wash & Dry**

Wash and dry a small load of laundry right in the washer.\*\* Whether it's a last-minute wardrobe change or a kid's jersey that has to be ready first thing, you can sleep easy while laundry practically does itself. Start the Overnight Wash & Dry cycle before you go to sleep, and clothes are ready to wear the next morning.



**Best Drying in the Industry†**

Quad baffles and Advanced Moisture Sensing combine for quick and even drying to provide the Best Drying Performance available for any size load.†



**10-Year Limited Parts Warranty††**

All new Maxima XL™ washers include a 10-year limited parts warranty on the washer motor and the stainless steel wash basket.†† Because these two important parts are covered, you won't have to worry about stocking up on quarters for the laundromat.



Visit maytag.com for warranty details.



**SoundGuard® Stainless Steel Dryer Drum**

The stainless steel drum is layered with sound-dampening material to offer quieter tumbling even when noise is generated by hard objects like coins, buckles and buttons.



NOTE: Not all features are available on all models.  
 \*Among leading front load brands, comparable cycles and settings. \*\*Based on a 2-lb load of lightweight fabrics, 12-hour cycle.  
 †Among front load brands, based on equal weighting of time and energy to reach a set dryness level, 18-lb load, heavy duty cycle. ††Visit maytag.com for warranty details.



**NEW MHW6000A**

4.3 cu. ft. capacity

W/G



**NEW MHW7000A**

4.3 cu. ft. capacity

W/G



**NEW MHW8000A**

4.3 cu. ft. capacity

W/G



**COLOR OPTIONS**



**W**  
White

**G**  
Granite

**LIMITED PARTS WARRANTY COVERED MODELS**



Visit [maytag.com](http://maytag.com) for warranty details.

**MHW6000A**  
**MHW7000A**  
**MHW8000A**



All Maxima XL™ high-efficiency front load washers are ENERGY STAR® qualified.

MODELS	NEW MODELS		
	MHW6000A	MHW7000A	MHW8000A
10-year limited parts warranty* on motor and wash basket	•	•	•
Capacity (cu. ft.)	4.3	4.3	4.3
Cycles/Options	11/7	11/7	11/9
PowerWash® system			•
Optimal Dose dispenser			•
PowerSpray technology			•
PowerWash® cycle	•	•	•
Steam	•	•	•
<b>EFFICIENCY</b>			
CEE qualified**	Tier 3	Tier 3	Tier 3
ENERGY STAR® qualified	•	•	•
Energy use†	86% less	85% less	85% less
Water use†	82% less	<b>83% less</b>	83% less
<b>CYCLES</b>			
Allergen	•	•	•
Bedding	•	•	•
Clean Washer with affresh®	•	•	•
Cold Wash	•	•	•
Delicates	•	•	•
Drain & Spin	•	•	•
Normal	•	•	•
Overnight Wash & Dry		•	•
PowerWash®	•	•	•
Rapid Wash	•		
Sanitize	•	•	•
Wrinkle Control	•	•	•
<b>OPTIONS</b>			
Control Lock	•	•	•
Delay Start	•	•	•
Detergent Concentration			•
Drum Light		•	•
End-of-Cycle signal	•	•	•
Extra Rinse	•	•	•
Fresh Hold®		•	•
Fresh Spin™	•		
Max Extract™ extended spin	•	•	•
Soil Levels	3	3	3
Steam for Stains	•	•	•
Temperatures	5	5	5
Water Hardness			•
<b>ADDITIONAL FEATURES</b>			
Advanced Vibration Control™ Plus	•	•	•
Automatic load size determination	•	•	•
Automatic temperature control	•	•	•
Basket material	Stainless steel	Stainless steel	Stainless steel
Digital LED display	•	•	•
Direct Drive motor	•	•	•
Heater	•	•	•
Max spin speed	1,160 RPM	<b>1,360 RPM</b>	1,360 RPM
QuietSeries™ sound package	•	•	•
<b>ACCESSORIES</b>			
Laundry Pair Stack Kit	W10298318RP	W10298318RP	W10298318RP
Optimal Dose dispenser replacement cartridge			W10250743A
Pedestal with chrome accents	XHPC155X	XHPC155X	XHPC155X
<b>MAYTAG® COMMERCIAL TECHNOLOGY</b>			
Durable pump impeller	•	•	•
Nickel-plated, rust-resistant dampers	•	•	•
Zinc-coated, corrosion-resistant springs	•	•	•
<b>SPECIFICATIONS</b>			
Overall dimensions (height x width x depth)	38-3/4" – 39-3/4" x 27" x 32-15/16"	38-3/4" – 39-3/4" x 27" x 32-15/16"	38-3/4" – 39-3/4" x 27" x 32-15/16"
Color options	W/G	W/G	W/G
Recommended dryer	ME/GD6000A	ME/GD7000A	ME/GD8000A

**Bold type indicates step-up feature**

Feature glossary can be found on page 42.  
 Complete product specifications can be found on page 44.  
 Accessories can be found on page 146.

\*Visit maytag.com for warranty details. \*\*Based on the Consortium for Energy Efficiency qualifying product list. Visit cee1.org for more information.  
 †Compared to pre-2004 traditional top load washers.



**NEW ME/GD6000A**

7.4 cu. ft. capacity

W/G



Steam



**NEW ME/GD7000A**

7.4 cu. ft. capacity

W/G



Steam



**NEW ME/GD8000A**

7.4 cu. ft. capacity

W/G



Steam



**COLOR OPTIONS**



**W**  
White



**G**  
Granite



All Maxima XL™ dryers feature high-efficiency sensor drying.



ELECTRIC MODELS GAS MODELS	NEW MODELS		
	MED6000A MGD6000A	MED7000A MGD7000A	MED8000A MGD8000A
Advanced Moisture Sensing	•	•	•
Capacity (cu. ft.)	7.4	7.4	7.4
Cycles/Options	9/7	<b>10/8</b>	10/8
High-efficiency model	•	•	•
Stainless steel drum	•	•	<b>SoundGuard® dryer drum</b>
Steam	•	•	•
<b>CYCLES</b>			
Bedding	•	•	•
Custom Refresh with Steam		•	•
Delicates	•	•	•
Heavy Duty	•	•	•
Normal	•	•	•
Rapid Dry	•	•	•
Refresh with Steam	•	•	•
Sanitize	•	•	•
Timed Dry	•	•	•
Wrinkle Control	•	•	•
<b>OPTIONS</b>			
Control Lock	•	•	•
Damp Dry signal	•	•	•
Drum Light	•	•	•
Dryness Levels	3	3	3
End-of-Cycle signal	•	•	•
Number of Garments (Custom Refresh)		•	•
Reduce Static	•	•	•
Steam Boost	•	•	•
Temperatures	3	3	3
Timed Dry Adjust	•	•	•
Wrinkle Prevent with Steam	•	•	•
<b>ADDITIONAL FEATURES</b>			
Digital LED display	•	•	•
Direct fill steam reservoir via Y-connector	•	•	•
Enhanced airflow monitor	•	•	•
Quad baffles	•	•	•
QuietSeries™ sound package	•	•	•
Reversible door	•	•	•
<b>ACCESSORIES</b>			
Dryer Rack	W10322470A	W10322470A	W10322470A
Laundry Pair Stack Kit	W10298318RP	W10298318RP	W10298318RP
Pedestal with chrome accents	XHPC155X	XHPC155X	XHPC155X
Steam hose kit	W10473735	W10473735	W10473735
<b>MAYTAG® COMMERCIAL TECHNOLOGY</b>			
5-rib dryer belt	•	•	•
Durable high torque motor	•	•	•
<b>SPECIFICATIONS</b>			
Overall dimensions (height x width x depth)	38-3/4" – 39" x 27" x 31"	38-3/4" – 39" x 27" x 31"	38-3/4" – 39" x 27" x 31"
Color options	W/G	W/G	W/G
Recommended washer	MHW6000A	MHW7000A	MHW8000A

**Bold type indicates step-up feature**



# Maxima X™

High-Efficiency Front Load Laundry Pairs

Models shown: MHW4200BG & ME/GD4200BG  
Shown with 15.5" pedestals, model XHPC155XG



### PowerWash® Cycle

The PowerWash® cycle combines extra cleaning action, heated water, extended wash time, stain-releasing steam and thorough rinsing for the perfect defense against the tough and heavy soils your life brings on.



### Fresh Spin™ Option

For those times when you can't move your clothes to the dryer right away, we offer the Fresh Spin™ option. The washer periodically tumbles wet clothes for up to six hours after the cycle's end to help keep clean clothes fresh.\*



### Evenly Dries Your Largest Loads\*\*

The extra-large 7.4 cu. ft. capacity provides enough space to evenly dry your largest loads\*\* straight from the washer.



### 10-Year Limited Parts Warranty†

Maytag® Maxima X™ washers include a 10-year limited parts warranty on the washer motor and the stainless steel wash basket.† Laundry doesn't do itself, but when two of the most important components of the washer are covered for 10 years, it will always get done.



Visit [maytag.com](http://maytag.com) for warranty details.



### Steam-Enhanced Dryer Cycles

Effectively relaxes wrinkles and refreshes clothes with a fine mist that's sprayed into the heated drum as it tumbles to create steam that penetrates fabric fibers.





**NEW MHW3000B**

4.1 cu. ft. capacity

W



**NEW MHW4200B**

4.1 cu. ft. capacity

W/G



**COLOR OPTIONS**



**W**  
White

**G**  
Granite

**LIMITED PARTS WARRANTY COVERED MODELS**



**MHW3000B**  
**MHW4200B**

Visit [maytag.com](http://maytag.com) for warranty details.



All Maxima X™ high-efficiency front load washers are ENERGY STAR® qualified.

MODELS	NEW MODELS	
	MHW3000B	MHW4200B
10-year limited parts warranty* on motor and wash basket	•	•
Capacity (cu. ft.)	4.1	4.1
Cycles/Options	8/4	<b>11/7</b>
PowerWash® cycle		•
Steam		•
<b>EFFICIENCY</b>		
CEE qualified**	Tier 3	Tier 3
ENERGY STAR® qualified	•	•
Energy use†	86% less	83% less
Water use†	76% less	76% less
<b>CYCLES</b>		
Allergen		•
Bedding		•
Clean Washer with affresh®	•	•
Cold Wash	•	•
Delicates	•	•
Drain & Spin	•	•
Heavy Duty	•	
Normal	•	•
PowerWash®		•
Rapid Wash	•	•
Sanitize		•
Sanitize with Oxi	•	
Wrinkle Control		•
<b>OPTIONS</b>		
Control Lock	•	•
Delay Start	•	•
End-of-Cycle signal		•
Extra Rinse	•	•
Fresh Spin™		•
Soil Levels	3	3
Steam for Stains		•
Temperatures	3	<b>5</b>
<b>ADDITIONAL FEATURES</b>		
Advanced Vibration Control™	•	•
Automatic load size determination	•	•
Automatic temperature control	•	•
Basket material	Stainless steel	Stainless steel
Digital LED display	•	•
Direct Drive motor	•	•
Heater		•
Max spin speed	1,160 RPM	1,160 RPM
QuietSeries™ sound package	•	•
<b>ACCESSORIES</b>		
Laundry Pair Stack Kit	W10298318RP	W10298318RP
Pedestal with chrome accents	XHPC155X	XHPC155X
<b>MAYTAG® COMMERCIAL TECHNOLOGY</b>		
Nickel-plated, corrosion resistant dampers	•	•
Zinc-coated, corrosion resistant springs	•	•
<b>SPECIFICATIONS</b>		
Overall dimensions (height x width x depth)	38-3/4" – 39-3/4" x 27" x 32-15/16"	38-3/4" – 39-3/4" x 27" x 32-15/16"
Color options	W	W/G
Recommended dryer	ME/GD3000B	ME/GD4200B

**Bold type indicates step-up feature**

Feature glossary can be found on page 42.  
 Complete product specifications can be found on page 45.  
 Accessories can be found on page 146.

\*Visit maytag.com for warranty details. \*\*Based on the Consortium for Energy Efficiency qualifying product list. Visit cee1.org for more information.  
 †Compared to pre-2004 traditional top load washers.



**NEW ME/GD3000B**

7.4 cu. ft. capacity

W



**NEW ME/GD4200B**

7.4 cu. ft. capacity

W/G



Steam

**COLOR OPTIONS**



**W**  
White



**G**  
Granite



All Maxima X™ front load dryers feature high-efficiency sensor drying.

ELECTRIC MODELS GAS MODELS	NEW MODELS	
	MED3000B MGD3000B	MED4200B MGD4200B
Advanced Moisture Sensing	•	•
Capacity (cu. ft.)	7.4	7.4
Cycles/Options	6/4	9/4
High-efficiency model	•	•
Stainless steel drum	•	•
Steam		•
<b>CYCLES</b>		
Air Dry	•	
Bedding		•
Delicates	•	•
Heavy Duty	•	•
Normal	•	•
Rapid Dry	•	•
Refresh with Steam		•
Sanitize		•
Timed Dry	•	•
Wrinkle Control		•
<b>OPTIONS</b>		
Control Lock	•	•
Damp Dry signal		•
Drum Light		•
Dryness Levels	3	3
End-of-Cycle signal		•
Temperatures	3	5
Timed Dry Adjust	•	•
Wrinkle Prevent	•	•
<b>ADDITIONAL FEATURES</b>		
Digital LED display	•	•
Direct fill steam reservoir via Y-connector		•
Quad baffles	•	•
QuietSeries™ sound package	•	•
Reversible door	•	•
<b>ACCESSORIES</b>		
Dryer Rack	W10322470A	W10322470A
Laundry Pair Stack Kit	W10298318RP	W10298318RP
Pedestal with chrome handle	XHPC155X	XHPC155X
Steam hose kit	W10473734	W10473734
<b>MAYTAG® COMMERCIAL TECHNOLOGY</b>		
5-rib dryer belt	•	•
Durable high-torque motor	•	•
<b>SPECIFICATIONS</b>		
Overall dimensions (height x width x depth)	38-3/4" - 39" x 27" x 31"	38-3/4" - 39" x 27" x 31"
Color options	W	W/G
Recommended washer	MHW3000B	MHW4200B

**Bold type indicates step-up feature**



# Bravos XL<sup>®</sup>

High-Efficiency Top Load Laundry Pairs





### Best Cleaning in the Industry\*

Select washers deliver the Best Cleaning in the industry,\* enabled by the PowerWash® system. The PowerWash® system uses our unique PowerSpray technology, optimal dispensers and the PowerWash® cycle to help power out even the toughest stains.



### 10-Year Limited Parts Warranty\*\*

Bravos XL® washers include a 10-year limited parts warranty on the washer motor and the stainless steel wash basket.\*\* Because these two important parts are covered, you won't have to worry about stocking up on quarters for the laundromat.



Visit [maytag.com](http://maytag.com) for warranty details.



### Maytag® Commercial Technology

Maytag brand washers are known for their dependability. The new Bravos XL® washers continue that legacy with long-lasting, commercial-grade components such as corrosion-resistant springs, a Direct Drive motor and a durable IntelliClean™ impeller.



### Steam Enhanced Dryer Cycles

The Steam Boost option adds a fine mist that is sprayed into the dryer during the cycle to create steam that helps smooth wrinkles. It is available on all cycles and can be used with high, medium-high or medium heat settings.



### Evenly Dries Your Largest Loads†

Worrying about whether you have the space to dry all your clothes is a thing of the past. With an enormous 7.3 cu. ft. capacity dryer, you have enough space to evenly dry your largest loads.†

\*For Bravos XL® washers MVWB980B and MVWB880B: among leading top load brands, comparable cycles and default settings. \*\*Visit [maytag.com](http://maytag.com) for warranty details. †Based on testing of an 18-lb load.



**NEW MVWB700B**

4.5 cu. ft. capacity

W



**NEW MVWB725B**

4.5 cu. ft. capacity

W



**NEW MVWB880B**

4.8 cu. ft. capacity

W



**NEW MVWB980B**

4.8 cu. ft. capacity

W/G



**COLOR OPTIONS**



**W**  
White

**G**  
Granite

**LIMITED PARTS WARRANTY COVERED MODELS**



**MVWB700B**  
**MVWB725B**  
**MVWB880B**  
**MVWB980B**

Visit [maytag.com](http://maytag.com) for warranty details.



All Bravos XL® high-efficiency top load washers are ENERGY STAR® qualified.

MODELS	NEW MODELS			
	MVWB700B	MVWB725B	MVWB880B	MVWB980B
10-year limited parts warranty* on motor and wash basket	•	•	•	•
Capacity (cu. ft.)	4.5	4.5	<b>4.8</b>	4.8
Cycles/Options	10/19	10/19	<b>13/21</b>	16/26
IntelliClean™ impeller	•	•	•	•
PowerWash® system	•	•	•	•
Optimal dispensers	•	•	•	•
PowerSpray technology	•	•	•	•
PowerWash® cycle	•	•	•	•
Steam				•
<b>EFFICIENCY</b>				
CEE qualified†	Tier 3	Tier 3	Tier 3	Tier 3
Energy use**	82% less	82% less	82% less	82% less
ENERGY STAR® qualified	•	•	•	•
Water use**	74% less	74% less	74% less	74% less
<b>CYCLES</b>				
Active Wear				•
Allergen			•	•
Bulky	•	•	•	•
Clean Washer with affresh®	•	•	•	•
Cold Wash			•	•
Colors/Towels			•	•
Delicate/Handwash	•	•	•	•
Heavy Duty	•	•	•	•
Normal	•	•	•	•
PowerWash®	•	•	•	•
Rapid Wash	•	•	•	•
Rinse/Drain & Spin	•	•	•	•
Sanitary with Oxi and Steam				•
Sheets	•	•	•	•
Soak				•
Whites	•	•	•	•
<b>OPTIONS</b>				
Clean Boost with Heater				•
Clean Washer Reminder Reset	•	•	•	•
Delay Start				•
End-of-Cycle signal	•	•	•	•
Extra Rinse	•	•	•	•
Fabric Softener	•	•	•	•
Oxi Treat Stains				•
Soil Levels	3	3	<b>4</b>	4
Spin Speeds	3	3	<b>4</b>	4
Temperatures	4	4	4	<b>5</b>
Water Save Spray Rinse	•	•	•	•
<b>ADDITIONAL FEATURES</b>				
1,200-watt water heater				•
Automatic temperature control	•	•	•	•
Basket material	Stainless steel	Stainless steel	Stainless steel	Stainless steel
Dispensers	Detergent, bleach & fabric softener	Detergent, bleach & fabric softener	Detergent, bleach & fabric softener	Detergent, fabric softener & bleach <b>w/Oxi</b>
Max spin speed	1,100 RPM	1,100 RPM	1,100 RPM	1,100 RPM
QuietSeries™ sound package	•	•	•	•
Riser			•	•
SmoothClose™ lid	•	•	•	•
Window		•	<b>Smoked glass</b>	Smoked glass
<b>ACCESSORIES</b>				
5' Washer Inlet Hose Kit (2-pk)	8212641RP	8212641RP	8212641RP	8212641RP
6' Gooseneck Nylon Braided Fill Hose Kit (2-pk)	8212638RP	8212638RP	8212638RP	8212638RP
10' Washer Inlet Hose Kit (2-pk)	8212656RP	8212656RP	8212656RP	8212656RP
<b>MAYTAG® COMMERCIAL TECHNOLOGY</b>				
2X Life†† tested drive system	•	•	•	•
Corrosion-resistant springs	•	•	•	•
Direct Drive infinite speed motor	•	•	•	•
Full-width, commercial-grade glass window				•
Smooth Balance™ suspension system	•	•	•	•
Steel cabinet and reinforced baseframe	•	•	•	•
Zinc-coated, tuned leveling legs	•	•	•	•
<b>SPECIFICATIONS</b>				
Overall dimensions (height x width x depth)	42 - 44" x 27-9/16" x 27-5/8"	42 - 44" x 27-9/16" x 27-5/8"	45-1/2" x 27-9/16" x 27-5/8"	45-1/2" x 27-9/16" x 27-5/8"
Color options	W	W	W	W/G
Recommended dryer	ME/GDB700B	ME/GDB725B	ME/GDB880B	ME/GDB980B

**Bold type indicates step-up feature**

Feature glossary can be found on page 42.  
 Complete product specifications can be found on page 46.  
 Accessories can be found on page 146.

\*Visit maytag.com for warranty details. \*\*Compared to pre-2004 traditional top load washers.  
 †Based on the Consortium for Energy Efficiency qualifying product list. Visit ceel.org for more information.  
 ††Based on time accelerated, 20-year simulated testing, normal cycle and average use.



**NEW ME/GDB700B**

7.3 cu. ft. capacity

W



**NEW ME/GDB725B**

7.3 cu. ft. capacity

W



Steam



**NEW ME/GDB880B**

7.3 cu. ft. capacity

W



Steam



**NEW ME/GDB980B**

7.3 cu. ft. capacity

W/G



Steam

**COLOR OPTIONS**



**W**  
White

**G**  
Granite

ELECTRIC MODELS GAS MODELS	NEW MODELS			
	MEDB700B MGDB700B	MEDB725B MGDB725B	MEDB880B MGDB880B	MEDB980B MGDB980B
Advanced Moisture Sensing	•	•	•	•
Capacity (cu. ft.)	7.3	7.3	7.3	7.3
Cycles/Options	9/18	10/18	11/19	14/28
GentleBreeze™ drying system	•	•	•	•
High-efficiency model	•	•	•	•
Steam		•	•	•
<b>CYCLES</b>				
Active Wear				•
Auto Refresh		•	•	•
Bulky	•	•	•	•
Custom Refresh				•
Delicate	•	•	•	•
Denim				•
Freshen Up	•	•		
Heavy Duty	•	•	•	•
Normal	•	•	•	•
Sanitize			•	•
Sheets	•	•	•	•
Small Load	•	•	•	•
Timed Dry	•	•	•	•
Towels			•	•
Wrinkle Control	•	•	•	•
<b>OPTIONS</b>				
Damp Dry signal	•	•	•	•
Drum Light	•	•	•	•
Dryness Levels	4	4	5	5
End-of-Cycle signal	•	•	•	•
Number of Garments (Custom Refresh)				5
Reduce Static				•
Steam Boost				•
Temperatures	5	5	5	5
Time Adjust	•	•	•	•
Wrinkle Prevent	•	•	•	<b>with Steam</b>
<b>ADDITIONAL FEATURES</b>				
Digital LED display	•	•	•	•
Direct fill steam reservoir via Y-connector		•	•	•
DuraCushion™ dryer drum	•	•	•	•
Enhanced airflow monitor	•	•	•	•
Front lint filter	•	•	•	•
QuietSeries™ sound package	•	•	•	•
Reversible door	•	•	•	•
Riser			•	•
Vents up to 100 ft in a straight line	•	•	•	•
Window			<b>Smoked glass</b>	Smoked glass
<b>ACCESSORIES</b>				
2-Way Internal Bottom Vent Kit	49610	49610	49610	49610
6' Gooseneck Nylon Braided Fill Hose Kit (2-pk)	8212638RP	8212638RP	8212638RP	8212638RP
Dryer Rack	8577312A	8577312A	8577312A	8577312A
LP Gas Conversion Kit	W10317689	W10317689	W10317689	W10317689
L, R, External Side Vent Kit	49611	49611	49611	49611
<b>MAYTAG® COMMERCIAL TECHNOLOGY</b>				
5-rib dryer belt	•	•	•	•
High-performance motor	•	•	•	•
Premium dryer drum rollers	•	•	•	•
<b>SPECIFICATIONS</b>				
Overall dimensions (height x width x depth)	42" – 44" x 29" x 29-1/4"	42" – 44" x 29" x 29-1/4"	45-1/2" x 29" x 29-1/4"	45-1/2" x 29" x 29-1/4"
Color options	W	W	W	W/G
Recommended washer	MVWB700B	MVWB725B	MVWB880B	MVWB980B

**Bold type indicates step-up feature**



# Bravos X<sup>®</sup>

High-Efficiency Top Load Laundry Pairs



### Best Cleaning in its Class\*

This washer delivers the Best Cleaning in its class,\* enabled by the PowerWash® cycle. This cycle helps free your clothes from even the toughest stains.



### 10-Year Limited Parts Warranty\*\*

Bravos X® washers are backed by a 10-year limited parts warranty on the stainless steel wash basket and the washer motor.\* Laundry doesn't do itself, but when two of the most important components of the washer are covered for 10 years, it will always get done.



Visit [maytag.com](http://maytag.com) for warranty details.



### Fountain™ Impeller

This unique impeller repeatedly scoops up water and detergent from the bottom of your washer and moves it upwards through your clothes.



### Deep Water Wash Cycle

A Deep Water Wash cycle lets you add more water to your wash when you need it.



### Evenly Dries Your Largest Loads†

The GentleBreeze™ drying system with IntelliDry® sensor quickly and efficiently dries clothing with consistent results. As clothes move around the dryer drum, air moves in a counterclockwise loop to thoroughly dry the entire load, so you can count on even drying.†

NOTE: Not all features are available on all models. \*Among leading top load brands, 4.0 cu. ft. capacity or less, comparable cycles and default settings. \*\*Visit [maytag.com](http://maytag.com) for warranty details. †Based on testing of a 16-lb load.



**NEW MVWX500B**

3.8 cu. ft. capacity

W



**NEW MVWX600B**

3.8 cu. ft. capacity

W



**COLOR OPTION**



**W**  
White

**LIMITED PARTS WARRANTY COVERED MODELS**



Visit [maytag.com](http://maytag.com) for warranty details.

**MVWX500B**  
**MVWX600B**



All Bravos X® high-efficiency top load washers are ENERGY STAR® qualified.



MODELS	NEW MODELS	
	MVWX500B	MVWX600B
10-year limited parts warranty* on motor and wash basket	•	•
Capacity (cu. ft.)	3.8	3.8
Cycles/Options	11/13	<b>12/16</b>
Deep Water Wash option	•	•
Fountain™ impeller	•	•
PowerWash® system	•	•
Optimal dispensers	•	•
PowerWash® cycle	•	•
<b>EFFICIENCY</b>		
CEE qualified**	Tier 3	Tier 3
ENERGY STAR® qualified	•	•
Energy use†	81% less	81% less
Water use†	74% less	74% less
<b>CYCLES</b>		
Bulky/Sheets	•	•
Clean Washer with affresh®	•	•
Cold Wash	•	•
Deep Water Wash	•	•
Drain & Spin	•	•
Hand Wash	•	•
Normal	•	•
PowerWash®	•	•
Rinse & Spin	•	•
Sanitize with Oxi	•	•
Soak	•	•
Wrinkle Control	•	•
<b>OPTIONS</b>		
Extra Rinse	2	2
Fabric Softener	2	<b>3</b>
Soil Levels	4	<b>5</b>
Temperatures	5	5
<b>ADDITIONAL FEATURES</b>		
Basket material	Stainless steel	Stainless steel
Dispensers	Detergent & fabric softener	Detergent, fabric softener & <b>Oxi</b>
Max spin speed	800 RPM	800 RPM
QuietSeries™ sound package	•	•
Window	•	•
<b>ACCESSORIES</b>		
5' Nylon Braided Washer Fill Hose Kit (2-pk)	8212487RP	8212487RP
6' Gooseneck Nylon Braided Fill Hose Kit (2-pk)	8212638RP	8212638RP
10' Washer Inlet Hose Kit (2-pk)	8212656RP	8212656RP
<b>MAYTAG® COMMERCIAL TECHNOLOGY</b>		
Commercial-grade motor	•	•
Corrosion-resistant springs	•	•
Synthetic oil	•	•
<b>SPECIFICATIONS</b>		
Overall dimensions (height x width x depth)	43" x 27-1/2" x 27"	43" x 27-1/2" x 27"
Color option	W	W
Recommended dryer	ME/GDX500B	ME/GDX500B

**Bold type indicates step-up feature**

Feature glossary can be found on page 42.  
 Complete product specifications can be found on page 47.  
 Accessories can be found on page 146.

\*Visit maytag.com for warranty details. \*\*Based on the Consortium for Energy Efficiency qualifying product list. Visit cee1.org for more information.  
 †Compared to pre-2004 traditional top load washers.



**NEW ME/GDX500B**

7.0 cu. ft. capacity

W

 high efficiency  
**SensorDrying**

**COLOR OPTION**



**W**  
White

ELECTRIC MODEL GAS MODEL	NEW MODEL	
	MEDX500B	MGDX500B
Capacity (cu. ft.)	7.0	
Cycles/Options	11/11	
GentleBreeze™ drying system	•	
High-efficiency model	•	
IntelliDry® sensor	•	
Sensor Drying	3	
<b>CYCLES</b>		
Freshen Up	•	
Normal	•	
Sanitize	•	
Sensor Dry	3	
Timed Dry	6	
<b>OPTIONS</b>		
End-of-Cycle signal	3	
Temperatures	5	
Wrinkle Control	3	
<b>ADDITIONAL FEATURES</b>		
Drum light	•	
DuraCushion™ dryer drum	•	
QuietSeries™ sound package	•	
Reversible door	•	
<b>ACCESSORIES</b>		
Dryer Rack	8212450A	
LP Gas Conversion Kit	W10317689	
<b>MAYTAG® COMMERCIAL TECHNOLOGY</b>		
5-rib dryer belt	•	
High-performance motor	•	
Premium dryer drum rollers	•	
<b>SPECIFICATIONS</b>		
Overall dimensions (height x width x depth)	43" x 29" x 29-1/4"	
Color option	W	
Recommended washer	MVWX500B, MVWX600B	



# Centennial<sup>®</sup>

Top Load Laundry Pairs



**PowerWash® Cycle**

The PowerWash® cycle uses a combination of extra cleaning action and a thorough rinse to help remove even your toughest stains.



**Fountain™ Impeller**

This unique impeller repeatedly scoops up water and detergent from the bottom of your washer and moves it upwards through your clothes.



**Maytag® Commercial Technology**

Maytag brand washers are known for their long-lasting dependability. The new Centennial® washers continue that legacy with components like a commercial-grade motor, synthetic oil and corrosion-resistant springs.



**Get More Water When You Need It**

Whether it's a load size option or a Deep Water Wash cycle, Centennial® models let you add more water to your wash when you need it.



**GentleBreeze™ Drying System**

The GentleBreeze™ drying system with the IntelliDry® sensor quickly and efficiently dries clothing with consistent results. As clothes move around the dryer drum, air moves in a counterclockwise loop to thoroughly dry the entire load, so you can count on even drying.\*

NOTE: Not all features are available on all models.  
\*Based on testing of a 16-lb load.



**NEW MVWC200B**

3.6 cu. ft. capacity

W



**NEW MVWC300B**

3.6 cu. ft. capacity

W



**NEW MVWC425B**

3.8 cu. ft. capacity

W



**COLOR OPTION**



**W**  
White

MODELS	NEW MODELS		
	MVWC200B	MVWC300B	MVWC425B
Capacity (cu. ft.)	3.6	3.6	<b>3.8</b>
Cycles/Options	9/12	<b>10/15</b>	11/12
Fountain™ impeller			•
LoadFlex™ agitator	•	•	
PowerWash® cycle		•	•
<b>EFFICIENCY</b>			
CEE qualified*			<b>Tier 3</b>
ENERGY STAR® qualified			•
Energy use**			<b>81% less</b>
Water use**			<b>74% less</b>
<b>CYCLES</b>			
Bulky/Sheets		•	•
Clean Washer with affresh®	•	•	•
Cold Wash		•	•
Deep Water Wash			•
Drain & Spin	•	•	•
Hand Wash	•	•	•
Normal	•	•	•
PowerWash®		•	•
Rinse & Spin	•	•	•
Soak		•	•
Wrinkle Control	2	•	•
<b>OPTIONS</b>			
Extra Rinse	•	•	•
Fabric Softener	•	•	•
Load Size	4	4	<b>Automatic</b>
Soil Levels		<b>3</b>	3
Temperatures	4	4	5
<b>ADDITIONAL FEATURES</b>			
Basket material	White porcelain-on-steel	White porcelain-on-steel	<b>Stainless steel</b>
Dispensers	Bleach & fabric softener	Bleach & fabric softener	Bleach
Max spin speed	700 RPM	700 RPM	<b>800 RPM</b>
<b>ACCESSORIES</b>			
5' Washer Inlet Hose Kit (2-pk)	8212641RP	8212641RP	8212641RP
6' Gooseneck Nylon Braided Fill Hose Kit (2-pk)	8212638RP	8212638RP	8212638RP
10' Washer Inlet Hose Kit (2-pk)	8212656RP	8212656RP	8212656RP
<b>MAYTAG® COMMERCIAL TECHNOLOGY</b>			
Commercial-grade motor	•	•	•
Corrosion-resistant springs	•	•	•
Synthetic oil	•	•	•
<b>SPECIFICATIONS</b>			
Overall dimensions (height x width x depth)	43" x 27-1/2" x 27"	43" x 27-1/2" x 27"	43" x 27-1/2" x 27"
Color option	W	W	W
Recommended dryer	ME/GDC300B, ME/GDC400B	ME/GDC300B, ME/GDC400B	ME/GDC300B, ME/GDC400B

**Bold type indicates step-up feature**

Feature glossary can be found on page 42.  
 Complete product specifications can be found on page 48.  
 Accessories can be found on page 146.

\*Based on the Consortium for Energy Efficiency qualifying product list. Visit [cee1.org](http://cee1.org) for more information. \*\*Compared to pre-2004 traditional top load washers.



**NEW ME/GDC300B**

7.0 cu. ft. capacity

W



**NEW ME/GDC400B**

7.0 cu. ft. capacity

W

 high efficiency  
**SensorDrying**

**COLOR OPTION**



**W**  
White



ELECTRIC MODELS GAS MODELS	NEW MODELS	
	MEDC300B MGDC300B	MEDC400B MGDC400B
Capacity (cu. ft.)	7.0	7.0
Cycles/Options	14/5	12/ <b>8</b>
GentleBreeze™ drying system	•	•
High-efficiency model		•
IntelliDry® sensor		•
<b>CYCLES</b>		
Air Fluff	3	
Auto Dry	4	
Delicate		•
Freshen Up		•
Jeans		•
Normal	•	•
Sensor Dry		<b>3</b>
Timed Dry	7	6
<b>OPTIONS</b>		
End-of-Cycle Signal	2	2
Temperatures	3	<b>4</b>
Wrinkle Control		<b>2</b>
<b>ADDITIONAL FEATURES</b>		
Drum light	•	•
DuraCushion™ dryer drum	•	•
Reversible door	•	•
<b>ACCESSORIES</b>		
2-Way Internal Bottom Vent Kit	49610	49610
6' Gooseneck Nylon Braided Fill Hose Kit (2-pk)	8212638RP	8212638RP
Dryer Rack	8577312A	8577312A
LP Gas Conversion Kit	W10317689	W10317689
L, R, External Side Vent Kit	49611	49611
<b>MAYTAG® COMMERCIAL TECHNOLOGY</b>		
5-rib dryer belt	•	•
High-performance motor	•	•
Premium dryer drum rollers	•	•
<b>SPECIFICATIONS</b>		
Overall dimensions (height x width x depth)	43" x 29" x 29-1/4"	43" x 29" x 29-1/4"
Color option	W	W
Recommended washer	MVWC200B, MVWC300B, MVWC425B	MVWC200B, MVWC300B, MVWC425B

**Bold type indicates step-up feature**



# Specialty Laundry



## DependableClean™ Wash System

The LoadFlex™ agitator rolls clothes in a 100° arc through the wash and rinse cycles to provide reliable cleaning, wash after wash.



## Commercial-Grade, Stainless Steel Wash Basket

Resists chips, scratches and odors. Super-tough stainless steel maintains a smooth surface so it won't snag or pill fabrics.



## Metallic Console Styling

Metallic knobs highlight the strong, dependable console.



**ME/GT3800T**

2.4 cu. ft. washer capacity  
5.9 cu. ft. dryer capacity

W

ELECTRIC MODEL	MET3800T
GAS MODEL	MGT3800T
<b>WASHER FEATURES</b>	
Automatic bleach and fabric softener dispensers	•
Automatic temperature control	•
Capacity (cu. ft.)	2.4
Cycles	9
Delicates cycle	•
DependableClean™ wash system	•
Front panel dial controls	•
LoadFlex™ agitator	•
Metallic console styling	•
Porcelain-on-steel wash basket	•
Prewash cycle	•
QuietSeries™ sound package	200
Self-cleaning lint removal system	•
Smooth Balance™ suspension system	•
Speed combinations	3
Temperature settings	4
Water levels	3
<b>DRYER FEATURES</b>	
Adjustable degree of dryness	•
Air Fluff cycle	•
Automatic temperature control	•
Capacity (cu. ft.)	5.9
Cycles/Options	6/1
DuraCushion™ dryer drum	•
Front panel dial controls	•
GentleBreeze™ drying system	•
IntelliDry® sensor	•
Interior light	•
Metallic console styling	•
QuietSeries™ sound package	200
Temperature settings	3
Timed Dry cycle	•
Wrinkle Prevent option	•
<b>ACCESSORIES</b>	
Fill hose included	•
LP Gas Conversion Kit	3392235A
<b>SPECIFICATIONS</b>	
Overall dimensions (height x width x depth)	73" x 27" x 32"
Color option	W



**MHWC7500Y**

2.0 cu. ft. capacity

W



**MED7500Y**

3.8 cu. ft. capacity

W

WASHER MODEL	MHWC7500Y
Automatic detergent, bleach and fabric softener dispenser	•
Automatic temperature control	•
Capacity (cu. ft.)	2.0
Clean Washer cycle	•
Commercial-grade, stainless steel wash basket	•
Cycles/Options	8/6
Delay Start option	up to 12 hours
ENERGY STAR® qualified	•
Heavy Duty cycle	•
IntelliFill™ water level sensor	•
LED controls	•
Max Extract™ extended spin	•
Meets CEE Tier standards*	Tier 1
Normal cycle	•
Rapid Wash cycle	•
Second Rinse option	•
Self-cleaning lint removal system	•
Spin speed	up to 1,200 RPM
Temperature settings	3
TurboClean™ wash system	•

<b>SPECIFICATIONS</b>	
Color option	W
Dimensions (height x width x depth)	33-1/2" x 23-1/2" x 24"

<b>ELECTRIC DRYER MODEL</b>		MED7500Y
Capacity (cu. ft.)		3.8
Damp Dry cycle		Regular/Synthetic
GentleBreeze™ drying system		•
IntelliDry® sensor		•
Iron Dry cycle		Regular/Synthetic
Low/Delicate/Regular temperature		•
More Dry cycle		Regular/Synthetic
Normal cycle		Regular/Synthetic
Stainless steel dryer drum		•
Timed Dry cycle		20/40/60

<b>ACCESSORIES</b>	
Fill hose included	•
Stack Kit Included (W10178021)	•
<b>SPECIFICATIONS</b>	
Overall Dimensions (height x width x depth)	33-1/4" x 23-3/8" x 23-1/4"
Color option	W

**COLOR OPTION**



W  
White

\*Based on the Consortium for Energy Efficiency qualifying product list. Visit ceel.org for more information.

Feature glossary can be found on page 42.

Accessories can be found on page 146.

NOTE: Not all features are available on all models.

**#****10-Year Limited Parts Warranty\***

Some Maytag® washers and dryers include select components backed by a 10-year limited parts warranty† for long-lasting performance.

**2X Life Tested\*\***

Select Maytag brand laundry parts are tested to twice the average life expectancy to help ensure years of dependability.

**A****Advanced Moisture Sensing**

Select dryers use three sensors to monitor incoming and outgoing air temperatures and moisture levels to virtually eliminate overdrying and help save you money.

**Advanced Vibration Control™**

The suspension system minimizes wash drum movement during the spin cycle, and features additional padding to muffle noise and cushion vibration. Plus, enhanced software adjusts load distribution to reduce vibration and noise.

**Advanced Vibration Control™ Plus**

Enhanced with a combination of two ball-bearing balance rings, a six-point suspension system and advanced software, this easily handles the vibration of almost any load size.

**Allergen Cycle**

Select washers feature an allergen cycle that eliminates at least 95% of common allergens from fabrics like dust mites and pet dander.

**C****CEE Qualified**

All models that meet the Consortium for Energy Efficiency (CEE) standards are efficient, with the most efficient products qualifying as Tier 3.† Select markets qualify for CEE Tier rebates. Consult your local utility company for availability.

**Clean Washer Cycle**

This special cycle helps rid the wash basket and tub of odor-causing buildup. Add affresh® Washer Cleaner to enhance results.

**Cold Wash Cycle**

Extra cleaning action combines with PowerSpray technology and active soak to power out tough stains like wine, chocolate and ground-in dirt in cold water. Get the performance of a warm water wash with the energy savings of cold water.

**Commercial-Grade 5-Rib Dryer Belt**

The industry's widest dryer belt stays strong to last long on Maytag® dryers.

**Commercial-Grade Glass Window**

Strong scratch- and shatter-resistant glass on select lids and doors allows you to see your laundry as it washes and dries.

**Commercial-Grade Motor**

Extra power makes it possible to tumble larger loads with less wear on the motor of select dryers.

**Control Lock**

When activated, this feature prohibits unwanted changes from occurring due to accidental operation.

**Custom Refresh with Steam Cycle**

A fine mist is sprayed into the heated dryer drum as it tumbles, creating steam to help touch up loads that have been left in the dryer too long. The cycle ends with a brief cool down period.

**D****Deep Water Wash Cycle**

A Deep Water Wash cycle lets you add more water to your wash when you need it.

**Deep Clean with Heat**

By selecting this option, the internal water heater on select washers maintains water temperature throughout the entire wash cycle. This reduces the need for pretreating while enhancing cleaning performance.

**Delay Start Option**

Automatically starts the washer at a later time to accommodate your schedule and take advantage of reduced energy rates where available.

**DependableClean™ Wash System**

Keeps clothes looking their best. The LoadFlex™ agitator produces an oscillating 100° arc wash motion that rolls clothes through the wash and rinse cycles to provide a reliable clean, wash after wash.

**Digital LED Display**

Bright white, energy-efficient display lighting allows for easy viewing.

**Direct Drive Infinite Speed Motor**

Magnets propel the washer motor, assuring infinite wash, tumble and spin speeds of up to 1,360 RPM. Plus, the motor's 18 lb UL capacity rating is commercial-grade.

**Direct Fill Steam Reservoir**

A Y-connector delivers water from the cold water inlet directly to the dryer. It eliminates the need to fill a reservoir in dryers that feature steam cycles. Included with all steam dryers.

**DuraCushion™ Dryer Drum**

Provides a smooth, scratch-resistant surface for less friction and wear. Clothes gently glide along its surface without snagging or pilling.

**E****ENERGY STAR® Qualified**

An ENERGY STAR® qualification means the appliance exceeds the federal minimum efficiency standards as set forth by the Environmental Protection Agency and the U.S. Department of Energy, helping save money on utility bills.

**Enhanced Airflow Monitor**

Checks for any restrictions of airflow at the start of every cycle, then provides a convenient visual display of the dryer's venting performance.

**F****Fountain™ Impeller**

This unique impeller repeatedly scoops up water and detergent from the bottom of your washer and moves it upwards through your clothes.

**Fresh Hold® Option**

The Fresh Hold™ option uses a built-in fan and tumbling action to keep clothes fresh.

**Fresh Spin™ Option**

Clothes periodically tumble for up to six hours after cycle's end to remain fresh even if you don't move them to the dryer right away.

**G****GentleBreeze™ Drying System**

Quickly and efficiently dries clothing for more consistent results.

**H****High-Efficiency Dryer**

Uses less energy with multiple sensors that stop clothes when they're dry instead of prolonging the cycle for optimal efficiency.

**I****IntelliClean™ Impeller**

A wash plate with fins continuously moves clothes through the water, effectively cleaning without the use of an agitator.

**IntelliDry® Sensor**

Measures moisture levels as clothes dry to minimize the risk of overdrying. Clothes come out dry, yet cool to the touch.

**IntelliFill™ Water Level Sensor**

Built-in sensors match water usage to load size, saving both water and money.

**L****LoadFlex™ Agitator**

Flex fins and a spiral design massage clothing to wash away dirt, keeping whites white and colors bright.

\*Visit maytag.com for warranty details. \*\*For specific 2X Life parts, see specification charts.

†Based on the Consortium for Energy Efficiency qualifying product list. Visit cee1.org for more information.

**M****Max Extract™ Extended Spin Option**

Accelerates the load's final spin to remove moisture and reduce drying time.

**Maytag® Commercial Technology (MCT)**

Select Maytag brand washers and dryers feature long-lasting, commercial-grade components for your home, delivering a lifetime of strength and dependability.

**O****Optimal Dispensing**

Select Maytag® washers provide enhanced cleaning performance thanks to dispensers that release detergent and other additives at the optimal time.

**Optimal Dose Dispenser**

Works in unison with PowerSpray technology to supply the perfect mix of detergent and water throughout the beginning of the wash cycle. This provides significantly better cleaning performance while using less detergent. The dispensing compartment holds up to 12 loads of detergent.††

**Oxi Treat Option**

Automatically dispenses oxygenated stain-fighting liquid or powder pre-treater at the right time to tackle tough stains.

**P****Porcelain-on-Steel Wash Basket**

Resistant to scratches, stains and odors, this wash basket provides a smooth wash surface.

**PowerSpray Technology**

This exclusive technology ensures even detergent distribution for enhanced cleaning performance. A mixture of detergent and water is sprayed directly onto clothes to instantly start cleaning soils and stains.

**PowerWash® Cycle**

The PowerWash® cycle uses a combination of extra cleaning action and a thorough rinse to help remove even your toughest stains and deliver the Best Cleaning in the industry‡ on select washers.

**PowerWash® System**

The PowerWash® system uses our unique PowerSpray technology, optimal dispensers and the PowerWash® cycle to help remove even the toughest stains.

**Q****QuietSeries™ Sound Package**

Available on laundry pairs, specially designed sound absorbers and dampeners reduce noise for quieter operation and less household disruption.

**R****Rapid Dry Cycle**

Dry a small load quickly. This cycle tumbles clothes at high heat for less than 30 minutes and is ideal for sturdy, lightweight fabrics.

**Reduce Static Option**

Steam is introduced at the end of the cycle to help reduce static in the load.

**Refresh with Steam Cycle**

Reduces wrinkles and removes odors in as little as 15 minutes. A fine mist is sprayed into the heated dryer drum as it tumbles to create steam. The cycle ends with a brief cool down period.

**S****Sanitary Cycle with Oxi and Steam**

Wash temperature is increased and Oxi is added to remove 99.9% of household bacteria.††

**Smooth Balance™ Suspension System**

Reduces vibration and noise in the washer, keeping loads balanced while spinning at top performance. In the dryer, drum rollers work with drum glides for quiet operation and low vibration.

**SmoothClose™ Lid**

Keeps the lid on select washers from slamming shut, protecting fingers and eliminating unwanted noise.

**SoundGuard® Stainless Steel Dryer Drum**

This special stainless steel drum is designed to help reduce noise made by zippers, buttons and other hard objects while tumbling.

**Stainless Steel Wash Basket**

Resists chips, scratches and odors. Durable stainless steel maintains a smooth surface so it won't snag or pill fabrics. Select washers feature a tilted basket for easier access.

**SteamClean Option**

A boost of steam penetrates deep into fabric fibers to lift out and eliminate ground-in dirt and set-in soils for a more thorough clean.

**Steam for Stains Option**

Available with select wash cycles including Allergen and PowerWash®, this option uses a combination of water temperature and steam to provide the optimal environment for detergent enzymes to work on removing organic stains.

**W****Water Save Spray Rinse Option**

For improved energy efficiency, this option minimizes water use during spinning by spraying the load instead of filling up the washer.

**Wrinkle Prevent Option**

The dryer continues to tumble after clothes are dry, without heat, to help prevent wrinkles from setting in.

**Z****Zinc-Coated, Corrosion-Resistant Springs**

These commercial-grade, corrosion-resistant springs contribute to the dependable cleaning performance of Maytag brand's Better Built washers.

**Zinc-Coated, Tuned Leveling Legs**

Specially designed leveling legs minimize vibration during high washer spin speeds.

WASHER MODELS	MHW6000A	MHW7000A	MHW8000A
<b>CYCLES</b>			
Allergen	•	•	•
Bedding	•	•	•
Clean Washer with affresh®	•	•	•
Cold Wash	•	•	•
Delicates	•	•	•
Drain & Spin	•	•	•
Normal	•	•	•
Overnight Wash & Dry		•	•
PowerWash®		•	•
Rapid Wash	•		
Sanitize	•	•	•
Wrinkle Control	•	•	•
<b>OPTIONS</b>			
Control Lock	•	•	•
Delay Start	•	•	•
Detergent Concentration			•
Drum Light		•	•
End-of-Cycle signal	•	•	•
Extra Rinse	•	•	•
Fresh Hold®		•	•
Fresh Spin™	•		
Max Extract™ extended spin	•	•	•
Max spin speed	1,160 RPM	<b>1,360 RPM</b>	1,360 RPM
Soil Levels	3	3	3
Steam for Stains	•	•	•
Temperatures	5	5	5
Water Hardness			•
<b>DIMENSIONS</b>			
Height (A)	38-3/4" – 39-3/4"	38-3/4" – 39-3/4"	38-3/4" – 39-3/4"
Width (B)	27"	27"	27"
Depth (C)	32-15/16"	32-15/16"	32-15/16"
Approximate shipping weight	245 lbs	245 lbs	255 lbs

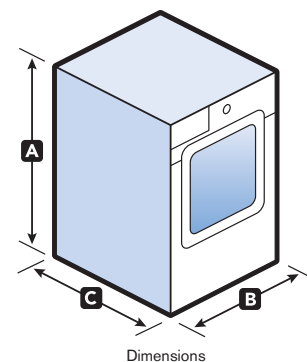

ELECTRIC DRYER MODELS	MED6000A	MED7000A	MED8000A
GAS DRYER MODELS	MGD6000A	MGD7000A	MGD8000A
<b>CYCLES</b>			
Bedding	•	•	•
Custom Refresh with Steam		•	•
Delicates	•	•	•
Heavy Duty	•	•	•
Normal	•	•	•
Rapid Dry	•	•	•
Refresh with Steam	•	•	•
Sanitize	•	•	•
Timed Dry	•	•	•
Wrinkle Control	•	•	•
<b>OPTIONS</b>			
Control Lock	•	•	•
Damp Dry signal	•	•	•
Drum Light	•	•	•
Dryness Levels	3	3	3
End-of-Cycle signal	•	•	•
Number of Garments (Custom Refresh)		•	•
Reduce Static	•	•	•
Steam Boost	•	•	•
Temperatures	3	3	3
Timed Dry Adjust	•	•	•
Wrinkle Prevent with Steam	•	•	•
<b>DIMENSIONS</b>			
Height (A)	38-3/4" – 39"	38-3/4" – 39"	38-3/4" – 39"
Width (B)	27"	27"	27"
Depth (C)	31"	31"	31"
Approximate shipping weight	Electric 140 lbs Gas 141 lbs	Electric 140 lbs Gas 141 lbs	Electric 175 lbs Gas 175 lbs

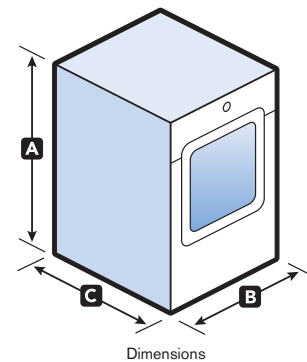

**Bold type indicates step-up feature**

Height dimensions will vary according to adjustment of leveling legs.  
 Dimensions shown are for planning purposes only.  
 See Installation Instructions packed with product for complete information.

WASHER MODELS	MHW3000B	MHW4200B
<b>CYCLES</b>		
Allergen		•
Bedding		•
Clean Washer with affresh®	•	•
Cold Wash	•	•
Delicates	•	•
Drain & Spin	•	•
Heavy Duty	•	
Normal	•	•
PowerWash®		•
Rapid Wash	•	•
Sanitize		•
Sanitize with Oxi	•	
Wrinkle Control		•
<b>OPTIONS</b>		
Control Lock	•	•
Delay Start	•	•
End-of-Cycle signal		•
Extra Rinse	•	•
Fresh Spin™		•
Max spin speed	1,160 RPM	1,160 RPM
Soil Levels	3	3
Steam for Stains		•
Temperatures	3	5
<b>DIMENSIONS</b>		
Height (A)	38-3/4" – 39-3/4"	38-3/4" – 39-3/4"
Width (B)	27"	27"
Depth (C)	32-15/16"	32-15/16"
Approximate shipping weight	214 lbs	216 lbs

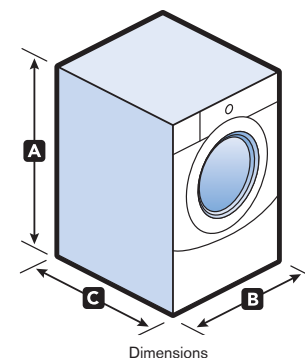

ELECTRIC DRYER MODELS	MED3000B	MED4200B
<b>GAS DRYER MODELS</b>		
<b>CYCLES</b>		
Air Dry	•	
Bedding		•
Delicates	•	•
Heavy Duty	•	•
Normal	•	•
Rapid Dry	•	•
Refresh with Steam		•
Sanitize		•
Timed Dry	•	•
Wrinkle Control		•
<b>OPTIONS</b>		
Control Lock	•	•
Damp Dry signal		•
Drum Light		•
Dryness Levels	3	3
End-of-Cycle signal		•
Temperatures	3	5
Timed Dry Adjust	•	•
Wrinkle Prevent	up to 140 minutes	up to 140 minutes
<b>DIMENSIONS</b>		
Height (A)	38-3/4" – 39"	38-3/4" – 39"
Width (B)	27"	27"
Depth (C)	31"	31"
Approximate shipping weight	137 lbs	146 lbs

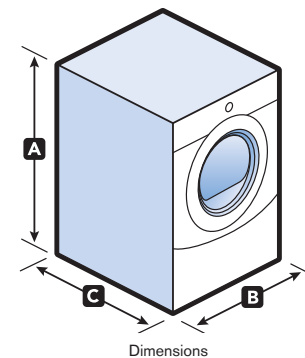

**Bold type indicates step-up feature**

Height dimensions will vary according to adjustment of leveling legs.  
 Dimensions shown are for planning purposes only.  
 See Installation Instructions packed with product for complete information.

WASHER MODELS	MVWB700B	MVWB725B	MVWB880B	MVWB980B
<b>CYCLES</b>				
Active Wear				•
Allergen			•	•
Bulky	•	•	•	•
Clean Washer with affresh®	•	•		•
Cold Wash			•	•
Colors/Towels			•	•
Delicate/Handwash	•	•	•	•
Heavy Duty	•	•	•	•
Normal	•	•	•	•
PowerWash®	•	•	•	•
Rapid Wash	•	•	•	•
Rinse/Drain & Spin	•	•	•	•
Sanitary with Oxi and Steam				•
Sheets	•	•	•	•
Soak				•
Whites	•	•	•	•
<b>OPTIONS</b>				
Clean Boost with Heater				•
Clean Washer Reminder Reset	•	•	•	•
Delay Start				•
End-of-Cycle signal	High/Low/Off	High/Low/Off	High/Low/Off	High/Low/Off
Extra Rinse	•	•	•	•
Fabric Softener	•	•	•	•
Oxi Treat Stains				•
Soil Levels	Light/Medium/Heavy	Light/Medium/Heavy	Light/Medium/Heavy/ <b>Extra heavy</b>	Light/Medium/Heavy/ Extra heavy
Spin Speeds	Low/Medium/Max Extract™	Low/Medium/Max Extract™	<b>No spin</b> /Low/Medium/ Max Extract™	No spin/Low/Medium/ Max Extract™
Temperatures	Cold/Cool/Warm/Hot	Cold/Cool/Warm/Hot	Cold/Cool/Warm/Hot	<b>Eco cold</b> /Cold/Cool/ Warm/Hot
Water Save Spray Rinse	•	•	•	•
<b>DIMENSIONS</b>				
Height (A)	42" – 44"	42" – 44"	45-1/2"	45-1/2"
Width (B)	27-9/16"	27-9/16"	27-9/16"	27-9/16"
Depth (C)	27-5/8"	27-5/8"	27-5/8"	27-5/8"
Approximate shipping weight	175 lbs	175 lbs	175 lbs	175 lbs

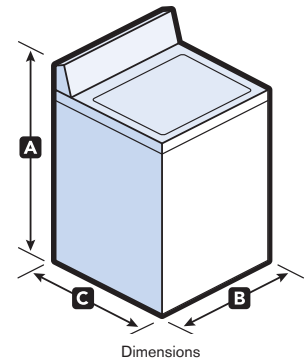

DRYER MODELS	MEDB700B	MEDB725B	MEDB880B	MEDB980B
GAS DRYER MODELS	MGDB700B	MGDB725B	MGDB880B	MGDB980B
<b>CYCLES</b>				
Active Wear				•
Auto Refresh with Steam		•	•	•
Bulky	•	•	•	•
Custom Refresh with Steam				•
Delicate	•	•	•	•
Denim				•
Freshen Up	•	•	•	•
Heavy Duty	•	•	•	•
Normal	•	•	•	•
Sanitize			•	•
Sheets	•	•	•	•
Small Load	•	•	•	•
Timed Dry	•	•	•	•
Towels			•	•
Wrinkle Control	•	•	•	•
<b>OPTIONS</b>				
Damp Dry signal	•	•	•	•
Drum Light	•	•	•	•
Dryness Levels	Damp/Less/Normal/More	Damp/Less/Normal/More	Damp/Less/Normal/More/ <b>Very</b>	Damp/Less/Normal/More/Very
End-of-Cycle signal	High/Low/Off	High/Low/Off	High/Low/Off	High/Low/Off
Number of Garments (Custom Refresh)				<b>1-2, 3-4, 5-6, 7-9, 10-12</b>
Reduce Static				•
Steam Boost				•
Temperatures	Air only/Extra low/Low/ Medium/High	Air only/Extra low/Low/ Medium/High	Air only/Extra low/Low/ Medium/High	Air only/Extra low/Low/ Medium/High
Wrinkle Prevent	up to 150 minutes	up to 150 minutes	up to 150 minutes	up to 150 minutes <b>with steam</b>
<b>DIMENSIONS</b>				
Height (A)	42" – 44"	42" – 44"	45-1/2"	45-1/2"
Width (B)	29"	29"	29"	29"
Depth (C)	29-1/4"	29-1/4"	29-1/4"	29-1/4"
Approximate shipping weight	156 lbs	156 lbs	156 lbs	156 lbs

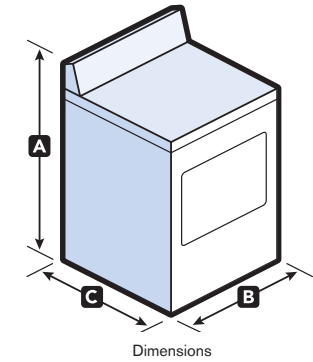

**Bold type indicates step-up feature**

Dimensions shown are for planning purposes only. See Installation Instructions packed with product for complete information.



WASHER MODELS	MVWX500B	MVWX600B
<b>CYCLES</b>		
Bulky/Sheets	•	•
Clean Washer with affresh®	•	•
Cold Wash	•	•
Deep Water Wash	•	•
Drain & Spin	•	•
Hand Wash	•	•
Normal	•	•
PowerWash®	•	•
Rinse & Spin	•	•
Sanitize with Oxi		•
Soak	•	•
Wrinkle Control	•	•
<b>OPTIONS</b>		
Extra Rinse	•	•
Fabric Softener	•	<b>with Oxi</b>
Oxi		•
Soil Levels	Extra Heavy/Heavy/Medium/Light	Extra Heavy/Heavy/Medium/ <b>Medium Light</b> /Light
Temperatures	Hot/Warm/Cool/Cold/Tap Cold	Hot/Warm/Cool/Cold/Tap Cold
<b>DIMENSIONS</b>		
Height (A)	43"	43"
Width (B)	27-1/2"	27-1/2"
Depth (C)	27"	27"
Height with lid open	53-2/5"	53-2/5"
Approximate shipping weight	135 lbs	135 lbs

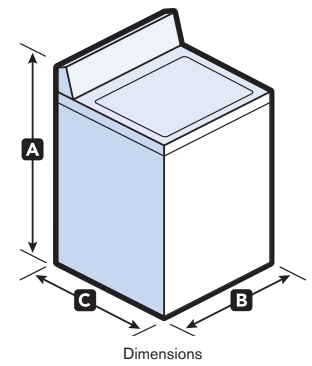

ELECTRIC DRYER MODEL	MEDX500B
GAS DRYER MODEL	MGDX500B
<b>CYCLES</b>	
Energy Preferred	•
Freshen Up	•
Less Dry	•
More Dry	•
Sanitize	•
Timed Dry	20-70 minutes
Wrinkle Control	•
<b>OPTIONS</b>	
End-of-Cycle signal	High/Low/Off
Temperatures	Sanitize/High/Medium/Low/Air Fluff
Wrinkle Control	•
<b>DIMENSIONS</b>	
Height (A)	43"
Width (B)	29"
Depth (C)	29-1/4"
Depth with door open	52-1/2"
Approximate shipping weight	120 lbs

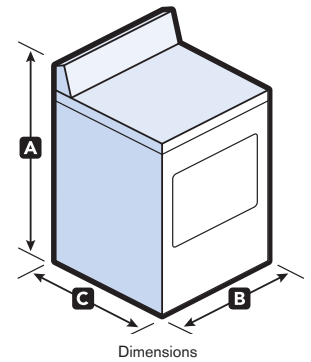

**Bold type indicates step-up feature**

Height dimensions will vary according to adjustment of leveling legs.  
 Dimensions shown are for planning purposes only.  
 See Installation Instructions packed with product for complete information.

WASHER MODELS	MVWC200B	MVWC300B	MVWC425B
<b>CYCLES</b>			
Bulky/Sheets		•	•
Cold Wash		•	•
Clean Washer with affresh®	•	•	•
Drain & Spin	•	•	•
Hand Wash	•	•	•
Normal	Heavy/Regular/Light	•	•
PowerWash®		•	•
Rinse & Spin	•	•	•
Soak		•	•
Wrinkle Control	•	•	•
<b>OPTIONS</b>			
Deep Water Wash			•
Extra Rinse	•	•	•
Fabric Softener	•	•	•
Load Size	Super/Large/Medium/Small	Super/Large/Medium/Small	<b>Automatic</b>
Soil Levels		<b>Heavy/Light/Regular</b>	Heavy/Light/Regular
Temperatures	Hot/Warm/Cool/Cold	Hot/Warm/Cool/Cold	Hot/Warm/Cool/Cold/ <b>Tap Cold</b>
<b>DIMENSIONS</b>			
Height (A)	43"	43"	43"
Width (B)	27-1/2"	27-1/2"	27-1/2"
Depth (C)	27"	27"	27"
Approximate shipping weight	136 lbs	132 lbs	132 lbs

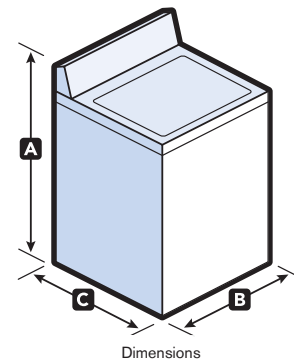

ELECTRIC DRYER MODELS	MEDC300B	MEDC400B
GAS DRYER MODELS	MGDC300B	MGDC400B
<b>CYCLES</b>		
Air Fluff	3	
Damp Dry	•	
Delicate		•
Energy Preferred	•	•
Freshen Up		•
Heavy Dry	•	•
Jeans		•
Less Dry	•	•
Normal Dry	•	
More Dry	•	•
Timed Dry	20-70 minutes	20-70 minutes
Wrinkle Control	•	•
<b>OPTIONS</b>		
End-of-Cycle signal	•	•
Temperatures	High/Medium/Low	High/Medium/Low/ <b>Air Fluff</b>
Wrinkle Control		<b>up to 90 minutes</b>
<b>DIMENSIONS</b>		
Height (A)	43"	43"
Width (B)	29"	29"
Depth (C)	29-1/4"	29-1/4"
Approximate shipping weight	125 lbs	125 lbs

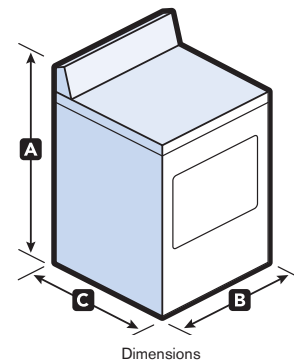

**Bold type indicates step-up feature**

Height dimensions will vary according to adjustment of leveling legs.  
 Dimensions shown are for planning purposes only.  
 See Installation Instructions packed with product for complete information.

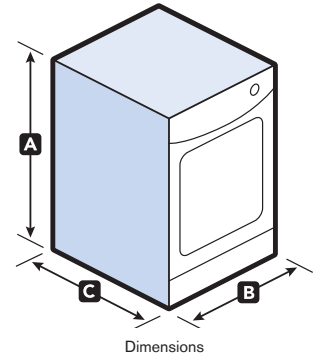
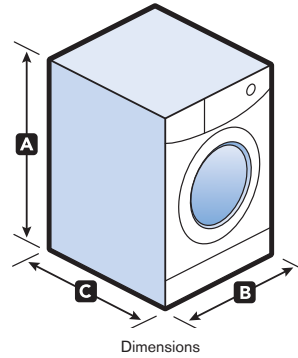
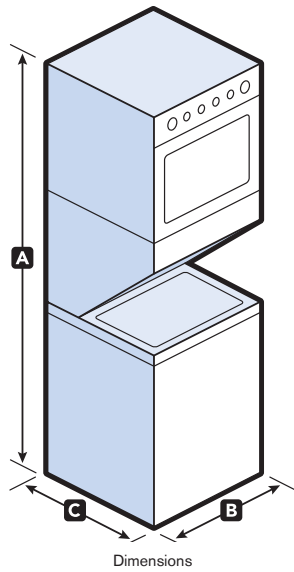

REFRIGERATION

STACKED LAUNDRY PAIR	MET3800T MGT3800T
<b>WASHER CYCLES</b>	
Casual Light	•
Casual Regular	•
Delicates Heavy	•
Delicates Light	•
Delicates Regular	•
Normal Heavy	•
Normal Light	•
Normal Regular	•
Prewash	•
<b>DRYER CYCLES</b>	
Air Fluff	•
Sensor Dry	High/Low Heat/More Dry
Sensor Dry	High/Low Heat/Energy Preferred
Sensor Dry	High/Low Heat/Less Dry
Timed Dry	•
Timed Dry	Freshen Up
<b>DRYER OPTIONS</b>	
Wrinkle Prevent	•
<b>DIMENSIONS</b>	
Height (A)	73"
Width (B)	27"
Depth (C)	32"
Depth with door open 90°	51-1/4"
Approximate shipping weight	Electric 312 lbs Gas 310 lbs

WASHER MODEL	MHWC7500Y
<b>CYCLES</b>	
Clean Washer	•
Delicates	•
Drain/Spin	•
Heavy Duty	•
Normal	•
Rapid Wash	•
Rinse/Spin	•
Wrinkle Control	•
<b>OPTIONS</b>	
Delay Start	•
Low Spin	•
Max Extract™	•
Prewash	•
Second Rinse	•
Wrinkle Prevent	•
<b>DIMENSIONS</b>	
Height (A)	33-1/2"
Width (B)	23-1/2"
Depth (C)	24"
Depth with door open 90°	36-1/4"
Approximate shipping weight	172 lbs

DRYER MODEL	MED7500Y
<b>CYCLES</b>	
Damp Dry cycle	Regular/Synthetic
Iron Dry cycle	Regular/Synthetic
Normal cycle	Regular/Synthetic
More Dry cycle	Regular/Synthetic
Timed Dry cycle	20/40/60
<b>DIMENSIONS</b>	
Height (A)	33-1/4"
Width (B)	23-3/8"
Depth (C)	23-1/4"
Depth with door open 90°	39"
Approximate shipping weight	89 lbs

Height dimensions will vary according to adjustment of leveling legs.  
Dimensions shown are for planning purposes only.  
See Installation Instructions packed with product for complete information.

REFRIGERATION



Model shown: MFT2976AEM

# BETTER BUILT COMPRESSOR\*

MAYTAG® REFRIGERATORS KEEP THEIR COOL EVEN IN A HEAT WAVE

\*Better Built compressors found in french door refrigerator models MFT2672AE and MFT2976AE.



French Door Refrigerators

**52**



Bottom-Freezer Refrigerators

**60**



Side-by-Side Refrigerators

**64**



Top-Freezer Refrigerators

**68**



# **French Door**

Refrigerators



### Cool Core™ Temperature Management

When it comes to consistent cooling, the new Ice<sub>2</sub>O® refrigerator has more at the core. With Cool Core™ temperature management, electronic sensors monitor temperatures and let the heart of the machine—the Better Built compressor—work with the Dual Cool® evaporators to send the right kind of cold just where you need it. So you can depend on fresh and frozen food staying its best.



### 10-Year Limited Parts Warranty\*

Select Maytag® refrigerators are backed by a 10-year limited parts warranty\* on the compressor. It is the most vital component of the refrigerator and acts as the engine that keeps food cold.



Visit [maytag.com](http://maytag.com) for warranty details.



### Store-N-Door® Dispensing System

By putting the ice bin in the door, we've given you the space to fit more groceries in the refrigerator. The ice bin is also removable, making it perfect for filling large containers, blenders for smoothies and more.



### Temperature-Controlled Wide-N-Fresh™ Deli Drawer

This drawer gives you the convenience to tackle after-school or late-night snack attacks. Complete with temperature controls, it is the ideal size for large party platters and deli trays.



### Easy Access Freezer Storage System

With the new Dual Level Flex Divider, we've got your freezer storage needs down cold. Designed to divide the freezer space for more flexible organization, this special compartment provides easy, adjustable access to frozen favorites by moving from one side to the other. There's even in-door pizza storage specifically designed to keep a quick meal within easy reach.



**MFI2269VE**  
22 cu. ft. capacity  
Ice<sub>2</sub>O® refrigerator  
W/B/M



**MFI2665XE**  
26 cu. ft. capacity  
Ice<sub>2</sub>O® refrigerator  
W/B/M



**NEW MFT2672AE**  
26 cu. ft. capacity  
Ice<sub>2</sub>O® refrigerator  
W/B/M



**MFT2976AE**  
29 cu. ft. capacity  
Ice<sub>2</sub>O® refrigerator  
W/B/M



**MFX2570AE**  
25 cu. ft. capacity  
Ice<sub>2</sub>O® 4-door refrigerator  
W/B/M





MODELS	MFI2269VE	MFI2665XE	<b>NEW MODEL</b> MFT2672AE	MFT2976AE	MF2570AE
10-year limited parts warranty* on compressor		•	•	•	•
Capacity (cu. ft.)	22	<b>26</b>	26	<b>29</b>	25
CEE qualified**	Tier 1	<b>Tier 2</b>	Tier 2	Tier 2	Tier 1
Cooling system	Quad Cool™	Quad Cool™	Quad Cool™	<b>Cool Core™ temperature management</b>	Quad Cool™
Dual Cool® evaporators				•	
ENERGY STAR® qualified	•	•	•	•	•
<b>REFRIGERATOR FEATURES</b>					
Accelerated cooling/ice mode	Max Cool	<b>Fast Cool</b>	<b>Fast Ice</b>	<b>Speed Cool</b> /Fast Ice	Speed Cool
Beverage Chiller™ compartment	•				
Bright white LED interior lighting			•	•	•
Contoured, french door styling	•	•	•	•	•
Door bins	1 Gallon, 1 Standard	<b>3 Gallon, 3 Standard</b>	<b>3 Clear extra-deep gallon, 3 Standard, 2-liter</b>	3 Clear extra-deep gallon, 3 Standard, 2-liter	3 Clear gallon, 3 Standard, <b>1 Wine holder</b>
Easy Access refrigerator drawer					•
EasyGlide™ adjustable					<b>2 Half-width</b>
Spill-Catcher™ glass shelves					
FreshFlow™ air filter			AIR1 (W10311524)	AIR1 (W10311524)	
FreshFlow™ produce preserver			FRESH1 (W10346771A)	FRESH1 (W10346771A)	
Humidity controlled FreshLock™ crispers	2	2	2	2	
Measured Fill					•
PUR® retractable water and ice filter with water filter indicator light	•	•	•	•	•
Removable drawer dividers			<b>1</b>	<b>1</b>	<b>2 with 1 organizer</b>
Spill-Catcher™ glass shelves	1 Full-width fixed, 3 Half-width	1 Full-width fixed, 3 Half-width, <b>1 Mini</b>	1 Full-width fixed, 3 Half-width <b>adjustable</b> , 1 Flip down	1 Full-width fixed <b>metal trim</b> , 3 Half-width adjustable <b>metal trim</b> , 1 Flip down <b>metal trim</b>	1 Full-width fixed, 1 Half-width adjustable, 1 Mini
Water filter cartridge replacement no.	FILTER4 (UKF8001)	FILTER4 (UKF8001)	FILTER2 (W10415645A)	FILTER2 (W10415645A)	FILTER4 (UKF8001)
Wide-N-Fresh™ deli drawer	Temperature controlled	•	Temperature controlled	Temperature controlled	
<b>FREEZER FEATURES</b>					
Bin organization system	2 Upper slide-out, 1 Lower	1 Upper, 1 Lower	<b>Easy Access system</b>	Easy Access system	<b>1 Upper slide-out, 1 Lower</b>
Factory-installed ice maker with ice bin	•	•	•	•	•
Glide-out freezer drawer with SmoothClose™ drawer track system	•	<b>2X Life† tested drawer glides</b>	2X Life† tested drawer glides	2X Life† tested drawer glides	2X Life† tested drawer glides
Ice system	Direct Chill	Direct Chill	<b>Store-N-Door®</b>	<b>Store-N-Door® with window</b>	Direct Chill
Lower basket/bin divider	•	•	•	•	•
Right Size ice cubes and crushed ice		•	•	•	•
Solid stainless steel ice maker auger	•	•	•	•	•
<b>EXTERIOR FEATURES</b>					
Door alarm	•	•	•	•	•
Durable metal handles††	•	•	•	•	•
Electronic control system	Push button	<b>Precision Touch</b>	Precision Touch	Precision Touch	Precision Touch
External filtered ice and water dispenser	•	<b>Flush dispenser</b>	Flush dispenser	Flush dispenser	Flush dispenser
Exterior temperature controls with lockout	•	•	•	•	•
Front Fill ice and water				•	
Hidden hinges	•	•	•	•	•
Power outage indicator				•	•
Sabbath Mode					•
<b>BETTER BUILT COMPONENTS</b>					
Compressor			•	•	
Patented door seal	•	•	•	•	•
Strongbox™ hinge design	•	•	•	•	•
<b>SPECIFICATIONS</b>					
Overall dimensions (height including hinges x width x depth including handles)	70-1/8" x 32-5/8" x 34-1/4"	70-1/8" x 35-5/8" x 35-1/4"	70-1/8" x 35-11/16" x 35-11/16"	69-15/16" x 35-5/8" x 35-11/16"	70-1/8" x 35-5/8" x 35-5/8"
Smooth door color options	W/B	W/B	W/B	W/B	W/B
Monochromatic door color option	M	M	M	M	M

Bold type indicates step-up feature

COLOR OPTIONS



**W**  
White with White Cabinet



**B**  
Black with Black Cabinet



**M**  
Monochromatic Stainless Steel with Apollo Gray Cabinet

LIMITED PARTS WARRANTY COVERED MODELS



Visit maytag.com for warranty details.

**MFI2665XE**  
**MFT2672AE**  
**MFT2976AE**  
**MF2570AE**

Refrigerator interiors can be found on page 58.  
Feature glossary can be found on page 76.  
Complete product specifications can be found on page 78.  
Accessories can be found on page 148.

\*Visit maytag.com for warranty details. \*\*Based on the Consortium for Energy Efficiency qualifying product list. Visit ceel.org for more information. †Freezer drawer glides tested to 300,000 openings and closings. ††Monochromatic stainless steel models only.



**MFF2055YE**  
20 cu. ft. capacity  
Fits a 30" opening  
W/B/M



**MFF2258VE**  
22 cu. ft. capacity  
W/B/M



**MFF2558VE**  
25 cu. ft. capacity  
W/B/M



**COLOR OPTIONS**



**W**  
White with  
White Cabinet

**B**  
Black with  
Black Cabinet

**M**  
Monochromatic Stainless Steel  
with Apollo Gray Cabinet

**LIMITED PARTS WARRANTY COVERED MODELS**



Visit [maytag.com](http://maytag.com) for warranty details.

**MFF2055YE**  
**MFF2258VE**  
**MFF2558VE**

MODELS	MFF2055YE	MFF2258VE	MFF2558VE
10-year limited parts warranty* on compressor	•	•	•
Capacity (cu. ft.)	20	<b>22</b>	<b>25</b>
CEE qualified**	Tier 2	Tier 1	Tier 1
Cooling system	Dual Cool®	Dual Cool®	Dual Cool®
ENERGY STAR® qualified	•	•	•
<b>REFRIGERATOR FEATURES</b>			
Accelerated cooling/ice mode	Speed Cool		
Beverage Organizer™ rack		•	•
Bright white LED interior lighting	•	•	•
Covered dairy compartment		•	•
Door bins	Tilt-N-Go	2 Clear gallon	2 Clear gallon
EasyGlide™ adjustable Spill-Catcher™ glass shelves	1 Full-width fold away		
FreshFlow™ air filter	AIR1 (W10311524)		
FreshFlow™ produce preserver	FRESH1 (W10346771A)		
Humidity controlled FreshLock™ crispers	2	2	2
PUR® retractable water and ice filter with water filter indicator light	Ice only		
Spill-Catcher™ glass shelves	1 Full-width fixed	1 Full-width fixed, <b>4 Half-width adjustable</b>	1 Full-width fixed, 4 Half-width adjustable
Temperature controlled Wide-N-Fresh™ deli drawer	•	•	•
Water filter cartridge replacement no.	FILTER1 (W10295370)		
<b>FREEZER FEATURES</b>			
Factory-installed ice maker with ice bin	•	•	•
Glide-out freezer drawer with SmoothClose™ drawer track system	•	•	•
Lower basket/bin divider	•	•	•
Slide-out baskets	1 Upper, 1 Lower	1 Upper, 1 Lower	1 Upper, 1 Lower
<b>EXTERIOR FEATURES</b>			
Contoured, french door styling	•	•	•
Door alarm	•		
Hidden hinges	•	•	•
QuietSeries™ sound package	•	•	•
Stainless finish handles†	•	•	•
<b>BETTER BUILT COMPONENTS</b>			
Patented door seal	•	•	•
Strongbox™ hinge design	•	•	•
<b>SPECIFICATIONS</b>			
Overall dimensions (height including hinges x width x depth including handles)	68-1/2" x 29-1/2" x 34-5/8"	70-1/8" x 32-5/8" x 34-1/2"	70-1/8" x 35-5/8" x 35-1/2"
Smooth door color options	W/B	W/B	W/B
Monochromatic door color option	M	M	M

**Bold type indicates step-up feature**

Refrigerator interiors can be found on page 58.  
 Feature glossary can be found on page 76.  
 Complete product specifications can be found on page 78.  
 Accessories can be found on page 148.

\*Visit maytag.com for warranty details. \*\*Based on the Consortium for Energy Efficiency qualifying product list. Visit cee1.org for more information. †Monochromatic stainless steel models only.



**MFI2269VE**  
22 cu. ft. capacity  
Ice2O® refrigerator  
W/B/M



**MFI2665XE**  
26 cu. ft. capacity  
Ice2O® refrigerator  
W/B/M



**MFX2570AE**  
25 cu. ft. capacity  
Ice2O® 4-door refrigerator  
W/B/M



**MFF2055YE**  
20 cu. ft. capacity  
Fits a 30" opening  
W/B/M





**NEW MFT2672AE**

26 cu. ft. capacity  
Ice2O® refrigerator  
W/B/M



**MFT2976AE**

29 cu. ft. capacity  
Ice2O® refrigerator  
W/B/M



**MFF2258VE**

22 cu. ft. capacity  
W/B/M



**MFF2558VE**

25 cu. ft. capacity  
W/B/M





# Bottom-Freezer

## Refrigerators



### Clear Deli Drawer

From bacon to bologna, keep all of your sandwich fixings in one spot. This drawer is the perfect place to store deli meat and cheese.



### Humidity Controlled FreshLock™ Crispers

Provides dependable storage for produce with humidity controls to help preserve the freshness of fruit and vegetables.



### Spill-Catcher™ Glass Shelves

The sealed edges of these glass shelves help contain spills for quick and easy cleanup.



**MBF1958XE**  
19 cu. ft. capacity  
Reversible door  
W/B/S ecoconserve refrigerator



**MBF2258XE**  
22 cu. ft. capacity  
Reversible door  
W/B ecoconserve refrigerator



**MBR2258XE**  
22 cu. ft. capacity  
Right opening door  
S ecoconserve refrigerator



**MBL2258XE**  
22 cu. ft. capacity  
Left opening door  
S ecoconserve refrigerator

MODELS	MBF1958XE	MBF2258XE	MBR2258XE MBL2258XE
Capacity (cu. ft.)	19	<b>22</b>	22
CEE qualified*	Tier 3	Tier 3	Tier 3
EcoConserve® model	•	•	•
ENERGY STAR® qualified	•	•	•
<b>REFRIGERATOR FEATURES</b>			
Automatic moisture control	•	•	•
BrightSeries™ lighting package	•	•	•
Clear deli drawer	•	•	•
Cooling system	Dual Cool®	Dual Cool®	Dual Cool®
Humidity controlled FreshLock™ crispers	2	2	2
Removable covered dairy compartment	•	•	•
Specialty door storage	1 Gallon shelf	1 Gallon shelf	1 Gallon shelf
Spill-Catcher™ glass shelves	1 Full-width fixed, 4 Half-width adjustable	1 Full-width fixed, 4 Half-width adjustable	1 Full-width fixed, 4 Half-width adjustable
<b>FREEZER FEATURES</b>			
Factory-installed ice maker with ice bin	•	•	•
Glide-out freezer drawer with SmoothClose™ drawer track system	•	•	•
Lower basket divider	•	•	•
Slide-out wire basket	2	2	2
<b>EXTERIOR FEATURES</b>			
QuietSeries™ sound package	•	•	•
Radius doors	•	•	•
Reversible door	•	•	•
<b>BETTER BUILT COMPONENTS</b>			
Foam-in-place insulation	•	•	•
Heavy-duty hinges	•	•	•
<b>SPECIFICATIONS</b>			
Overall dimensions (height including hinges x width x depth including handles)	66-15/16" x 29-5/8" x 33-3/8"	69-15/16" x 32-5/8" x 33-3/8"	69-15/16" x 32-5/8" x 33-3/8"
Smooth door color options	W/B	W/B	S
Stainless door color option	S		

**Bold type indicates step-up feature**

**COLOR OPTIONS**



**W**  
White with  
White Cabinet



**B**  
Black with  
Black Cabinet



**S**  
Stainless Steel

Refrigerator interiors can be found on page 62.  
Feature glossary can be found on page 76.  
Complete product specifications can be found on page 79.  
Accessories can be found on page 148.

\*Based on the Consortium for Energy Efficiency qualifying product list. Visit [cee1.org](http://cee1.org) for more information.



**MBF1958XE**  
19 cu. ft. capacity  
Reversible door  
W/B/S



**MBF2258XE**  
22 cu. ft. capacity  
Reversible door  
W/B







**MBR2258XE**  
22 cu. ft. capacity  
Right opening door



S



**MBL2258XE**  
22 cu. ft. capacity  
Left opening door



S





## Side-by-Side Refrigerators



### LED Lights

These long-lasting lights are engineered to cast a brighter, whiter light so everything in the refrigerator is easier to see. Plus, it uses less energy than incandescent bulbs.



### 10-Year Limited Parts Warranty\*

Select Maytag® refrigerators are backed by a 10-year limited parts warranty\* on the compressor. It is the most vital component of the refrigerator and acts as the engine that keeps food cold.



### Store-N-Door® Plus Dispensing System

By putting the ice bin in the door, we've given you 30% more usable freezer storage space.\*\* The ice bin is also removable, making it perfect for filling large containers like blenders.

Model shown: MSB27C2XAM

NOTE: Not all features are available on all models.

\*Visit [maytag.com](http://maytag.com) for warranty details. \*\*Compared to 25 cu. ft. Maytag® models with conventional ice makers.

**COLOR OPTIONS**



**W**  
White with  
White Cabinet



**B**  
Black with  
Black Cabinet



**M**  
Monochromatic Stain-  
less Steel with Apollo  
Gray Cabinet

**LIMITED PARTS WARRANTY COVERED MODELS**



**MSB27C2XA**

Visit [maytag.com](http://maytag.com) for warranty details.



**NEW**  
**MSF22D4XA**  
22 cu. ft. capacity  
W/B/M



**MSB27C2XA**  
27 cu. ft. capacity  
W/B/M



MODELS	NEW MODEL MSF22D4XA	MSB27C2XA
10-year limited parts warranty* on compressor		•
Capacity (cu. ft.)	22	<b>27</b>
CEE qualified†	Tier 1	<b>Tier 3</b>
ENERGY STAR® qualified	•	•
<b>REFRIGERATOR FEATURES</b>		
Adjusti-Temp™ deli drawer	•	•
BrightSeries™ lighting package	LED	LED
Covered dairy compartment	•	•
Exterior ice and water dispenser with night-light	•	•
Humidity controlled FreshLock™ crispers	•	•
PUR® push-button water and ice filter with water filter indicator light	•	•
Slide-out snack drawer	•	•
Specialty door bins	2 Clear gallon	<b>3</b> Clear gallon
Speed Cool		•
Spill-Catcher™ glass shelves	2 Adjustable, 1 Fixed	<b>3</b> Adjustable, 1 Fixed
Store-N-Door® Plus dispensing system		•
Temperature controls	Internal, up-front dial	<b>External</b>
Water filter cartridge replacement no.	FILTER1 (W10295370A)	FILTER1 (W10295370A)
<b>FREEZER FEATURES</b>		
Adaptive Defrost system	•	•
Factory-installed ice maker with auger and ice bin	•	•
Fast Ice accelerated ice production		•
Freezer door shelves	4 Standard	3 Standard
Freezer lighting	•	•
Freezer shelves	3 Fixed wire, 1 Adjustable wire	<b>3 Adjustable glass</b>
Plastic freezer basket	•	•
Right Size ice cubes and crushed ice	•	•
<b>EXTERIOR FEATURES</b>		
Built-in surge protector	•	•
Control lock	•	•
Door open alarm		•
Electronic control system	Push button	<b>Tap Touch</b>
Exterior temperature controls		•
<b>BETTER BUILT COMPONENTS</b>		
Durable metal handles††	•	•
Hidden hinges		•
<b>SPECIFICATIONS</b>		
Overall dimensions (height including hinges x width x depth including handles)	66-1/4" x 32-3/4" x 35"	69" x 35-1/2" x 34"
Smooth door color options	W/B	W/B
Stainless door color option	M	M

**Bold type indicates step-up feature**

Refrigerator interiors can be found on page 66.  
Feature glossary can be found on page 76.  
Complete product specifications can be found on page 79.  
Accessories can be found on page 148.

\*Visit [maytag.com](http://maytag.com) for warranty details. †Based on the Consortium for Energy Efficiency qualifying product list. Visit [cee1.org](http://cee1.org) for more information.  
††Monochromatic stainless steel models only.



**NEW MSF22D4XA**

22 cu. ft. capacity

W/B/M



**MSB27C2XA**

27 cu. ft. capacity

W/B/M







# Top-Freezer

Refrigerators



### 10-Year Limited Parts Warranty\*

Select Maytag® refrigerators are backed by a 10-year limited parts warranty\* on the compressor. It is the most vital component of the refrigerator and acts as the engine that keeps food cold.



Visit [maytag.com](http://maytag.com) for warranty details.



### Humidity Controlled FreshLock™ Crispers

These sealed crispers give you plenty of storage space, while the humidity control helps prolong the freshness of your fruits and vegetables.



### Industry-Exclusive Full-Width Fold-Away Shelf

The shelf's design makes it easy to store taller items on the shelf below. Unlike other brands, the fold-away section extends the entire width of the shelf, so you'll always have room for tall bottles and pitchers.



### Up-Front Electronic Controls

Placing the electronic controls at the front of the refrigerator makes it easy to adjust the temperature without having to move stored items out of the way.



### FreshFlow™ Produce Preserver

Produce preserver packets used in the crisper help absorb the ethylene gas that causes fruit and vegetables to over ripen, and helps produce stay fresher longer. Replace packet every six months for optimal performance.



**M8RXEGMA**  
18 cu. ft. capacity  
W/B/S



**M9BXXGMY**  
19 cu. ft. capacity  
W/B/M



**ecoconserve**  
refrigerator

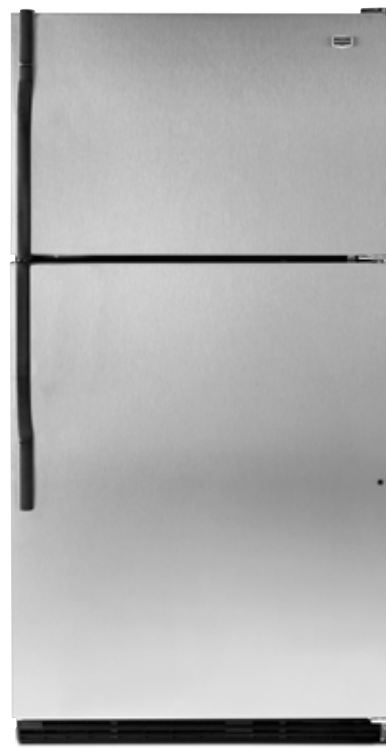

**M1TXEGMY**  
21 cu. ft. capacity  
W/Q/B/S



**M1BXXGMY**  
21 cu. ft. capacity  
W/B/M



**ecoconserve**  
refrigerator



MODELS	M8RXEGMA	M9BXXGMY	M1TXEGMY	M1BXXGMY
10-year limited parts warranty* on compressor		•		•
ADA compliant**		•	•	•
Capacity (cu. ft.)	18	<b>19</b>	<b>21</b>	21
CEE qualified†	Tier 1	<b>Tier 3</b>	Tier 1	<b>Tier 3</b>
EcoConserve® model		•		•
ENERGY STAR® qualified	•	•	•	•
<b>REFRIGERATOR FEATURES</b>				
Automatic moisture control		•	•	•
Clear deli drawer		•	•	•
Cool Flow™ ventilation		•		•
Covered dairy compartment	•	•		•
Flip-up utility shelf			•	
Fold-away shelf		<b>1 Full-width</b>		<b>1 Full-width</b>
FreshFlow™ air filter		<b>AIR1 (W10311524)</b>		<b>AIR1 (W10311524)</b>
FreshFlow™ produce preserver		<b>FRESH1 (W10346771A)</b>		<b>FRESH1 (W10346771A)</b>
Full-width gallon door shelf	•			
Full-width standard door shelf	•	•	•	•
Humidity controlled FreshLock™ crispers	2 Half-width	<b>2 Split-width</b>	2 Split-width	2 Split-width
Specialty door bins	3 Clear adjustable gallon	<b>3 Clear adjustable gallon, 1 Easy Access tilt out</b>	3 Adjustable gallon	<b>3 Clear adjustable gallon, 1 Easy Access tilt out</b>
Speed Cool		•		•
Spill-Catcher™ glass shelves	2 Full-width adjustable, 1 Full-width fixed	1 Full-width adjustable, 1 Full-width fixed	2 Full-width adjustable, 1 Full-width fixed	1 Full-width adjustable, 1 Full-width fixed, 1 Half-width adjustable
Up-front controls	Single knob	<b>Electronic</b>	Single knob	<b>Electronic</b>
<b>FREEZER FEATURES</b>				
Ice maker	Factory installed	Factory installed	Factory installed	Factory installed
Shelf	Full-width glass	Full-width wire	Full-width wire	Full-width wire
<b>EXTERIOR FEATURES</b>				
Door style	Contoured	Beveled	Flat	Beveled
Reversible doors	•	Door reversal kit (W10395149)	•	Door reversal kit (W10395149)
<b>BETTER BUILT COMPONENTS</b>				
Foam-in-place insulation	•	•	•	•
Heavy-duty hinges	•	•	•	•
<b>SPECIFICATIONS</b>				
Overall dimensions (height including hinges height x width x depth including handles)	68" x 28" x 30-3/8"	66-1/3" x 29-1/2" x 34"	66-1/4" x 32-1/2" x 32-3/4"	66-1/4" x 32-1/2" x 34"
Smooth door color options	W/B	W/B	W/Q/B	W/B
Stainless door color option	S	M	S	M

**Bold type indicates step-up feature**

**COLOR OPTIONS**



**W**  
White with White Cabinet



**Q**  
Bisque with Bisque Cabinet



**B**  
Black with Black Cabinet



**S**  
Stainless Steel with Black Cabinet



**M**  
Monochromatic Stainless Steel with Apollo Gray Cabinet

**LIMITED PARTS WARRANTY COVERED MODELS**



Visit [maytag.com](http://maytag.com) for warranty details.

**M9BXXGMY**  
**M1BXXGMY**

Refrigerator interiors can be found on page 72.  
Feature glossary can be found on page 76.  
Complete product specifications can be found on page 80.  
Accessories can be found on page 148.

\*Visit [maytag.com](http://maytag.com) for warranty details. \*\*Model meets ADA push/pull force and reach range guidelines and must be installed in compliance with current ADA Standards.  
†Based on the Consortium for Energy Efficiency qualifying product list. Visit [cee1.org](http://cee1.org) for more information.



**M8RXEGMA**  
18 cu. ft. capacity  
W/B/S



**M9BXXGMY**  
19 cu. ft. capacity  
W/B/M



**ecoconserve**  
refrigerator



**M1TXEGMY**  
21 cu. ft. capacity  
W/Q/B/S



**M1BXXGMY**  
21 cu. ft. capacity  
W/B/M



**ecoconserve**  
refrigerator



# Specialty Refrigeration



## Beverage Center

Store 12 standard bottles of wine and a variety of food and other beverages in two different temperature zones.



## Refrigerator

Keep food and beverages nearby and help save money on utility bills with this ENERGY STAR® qualified refrigerator.



## Ice Maker

Make entertaining a breeze by producing up to 50 lbs of ice every 24 hours and storing up to 25 lbs of ice at any time.

**MBCM24FWB**

5.8 cu. ft. capacity  
Stainless steel

**MURM24FWB**

5.7 cu. ft. capacity  
Stainless steel

**MIM1554XR  
MIM1555YR**

25-lb storage capacity  
Stainless steel

BEVERAGE CENTER MODEL	MBCM24FWB
Auto defrost	•
Capacity (cu. ft.)	5.8
Dual temperature zones	Top 38-48°F, Bottom 50-70°F
Exterior temperature control	•
Interior light	•
LED temperature display with dimmer	•
Removable, tempered-glass shelves	2
Reversible-swing door	•
UV-protected thermal glass door	•
Wine rack capacity (bottles)	12
BETTER BUILT COMPONENTS	
Heavy-duty hinges	•
High-efficiency compressor	•
Stainless steel handle	•
SPECIFICATIONS	
Overall dimensions (height x width x depth including handle)	34-5/8" - 35-1/8" x 23-3/4" x 26-13/16"
Color option	S

REFRIGERATOR MODEL	MURM24FWB
Capacity (cu. ft.)	5.7
Clear door bins	3
ENERGY STAR® qualified	•
Exterior temperature control	•
Frost-free design	•
Interior light	•
Removable, tempered-glass shelves	3
Reversible-swing door	•
Temperature range	34-50°F
BETTER BUILT COMPONENTS	
Heavy-duty hinges	•
High-efficiency compressor	•
Stainless steel handle	•
SPECIFICATIONS	
Overall dimensions (height x width x depth including handle)	34-5/8" - 35-1/8" x 23-3/4" x 26-13/16"
Color option	S

ICE MAKER MODELS	MIM1554XR	MIM1555YR
24-hour ice production	up to 50 lbs	up to 50 lbs
Auto ice level control/shutoff	•	•
Automatic Rinse cycle	•	•
Clean cycle with indicator light	•	•
Cleaning needed status light	•	•
Fast Ice	•	•
Ice condensate pump (part no.)	Optional (1901)	<b>Included (1901A)</b>
Ice scoop with holder	•	•
Ice storage capacity	up to 25 lbs	up to 25 lbs
Interior light	•	•
Reversible-swing door	•	•
Service indicator light	•	•
ACCESSORIES		
Stainless steel filler kit	8171487	8171487
Stainless steel trim kit	8171347	8171347
BETTER BUILT COMPONENTS		
Heavy-duty hinges	•	•
High-efficiency compressor	•	•
SPECIFICATIONS		
Overall dimensions (height x width x depth including handle)	33-5/8" - 34-3/8" x 14-7/8" x 24-3/8"	33-5/8" - 34-3/8" x 14-7/8" x 24-3/8"
Color option	S	S

**Bold type indicates step-up feature**

**#****10-Year Limited Parts Warranty\***

Some Maytag® refrigerators include select components backed by a 10-year limited parts warranty† for long-lasting performance.

**2X Life Tested\*\***

Select durable Maytag brand parts are tested to twice the average life expectancy to help ensure years of dependability.

**A****ADA Compliant**

Refrigerators with this feature meet standards set by the Americans with Disabilities Act for push/pull force, height and reach, and must be installed in compliance with current ADA Standards.

**Adaptive Defrost**

Saves energy by monitoring and minimizing the length of defrost cycles.

**Adjusti-Temp™ Deli Drawer**

Helps preserve freshness of meat, cheese and other deli items by allowing cool air from the freezer to enter the drawer at an adjustable level.

**B****Better Built Components**

Select Maytag® appliances feature certain components that are Better Built, providing the enhanced performance Maytag brand is known for.

**Better Built Compressor**

As the heart of the refrigerator, this Better Built compressor is engineered to deliver consistent performance for years of dependable cooling.

**Beverage Chiller™ Compartment**

Keeps gallon-size containers of milk, juice or other drinks up to 4°F colder than the rest of the refrigerator.

**Beverage Organizer™ Rack**

Opens up shelf space and keeps beverage cans and bottles neatly organized.

**BrightSeries™ Lighting Package**

Provides improved lighting for a brighter interior.

**C****CEE Qualified**

All models that meet the Consortium for Energy Efficiency (CEE) standards are efficient, with the most efficient products qualifying as Tier 3.† Select markets qualify for CEE Tier rebates. Consult your local utility company for availability.

**Control Lock**

When activated, this feature prohibits unwanted changes from occurring due to accidental operation.

**Cool Core™ Temperature Management**

Electronic sensors work with the Better Built compressor and Dual Cool® evaporators to send the right kind of cold just where you need it.

**Counter Depth Styling**

Fits virtually flush with surrounding cabinetry for an integrated kitchen design. Creates a built-in appearance without the built-in price while eliminating installation hassles.

**D****Direct Chill Ice System**

Dependably produces and stores ice by directing freezer air into the sealed icebox.

**Dual Cool® Cooling System**

Two thermostats closely monitor each compartment to help minimize wide temperature fluctuations.

**Dual Cool® Evaporators**

So you can depend on your fresh and frozen food staying its best, Dual Cool® evaporators generate separate humidity levels in the refrigerator and freezer.

**Dual Temperature Zones**

This specialty feature in the Beverage Center stores wine at an optimal temperature while also chilling other beverages at a different temperature.

**E****Easy Access Freezer Storage System**

Our Dual Level Flex Divider gives you easy access to frozen favorites, moving from one side to the other for flexible organization. There's even in-door pizza storage specifically designed to keep a quick meal within easy reach.

**Easy Access Refrigerator Drawer**

The fully extendable Easy Access refrigerator drawer holds up to five bags of groceries and provides accessibility even in the back. Two removable, adjustable dividers and one organizer create flexible storage options. Plus, this convenient counter-height drawer is easily accessible to the whole family, including children.

**EasyGlide™ Shelves**

These adjustable glass shelves slide in and out with minimal effort, making it easy to access items stored in the back of the refrigerator.

**EcoConserve® Refrigerators**

Exceeding federal minimum energy standards by 30%, these extra-efficient refrigerators are rated Tier 3† qualified by the Consortium for Energy Efficiency (CEE) and help save even more money on utility bills.

**ENERGY STAR® Qualification**

An ENERGY STAR® qualification means the appliance exceeds the federal minimum efficiency standards as set forth by the Environmental Protection Agency and the U.S. Department of Energy, helping save money on utility bills.

**Exterior Temperature Controls**

Located on the outside of the refrigerator, these convenient controls can be adjusted without even opening the door.

**External Filtered Ice and Water Dispenser**

Allows easy access to ice and chilled water, even for tall glasses and pitchers.

**Extra-Deep Gallon Door Bins**

These extra-large door bins store gallon-size containers and more. Bins are removable and adjustable for flexible loading and quick cleaning.

**F****Fast Cool and Max Cool**

*See Speed Cool Option.*

**Fast Ice**

Produces ice at an accelerated rate to help ensure there's always ice on hand.

**Fill-N-Chill™ Dispenser**

Conveniently dispenses ice and water at the same time, helping to lower the amount of time you spend standing at the dispenser.

**Flip-Up Utility Shelf**

Located in the refrigerator door, this convenient shelf can securely hold smaller items. It can also be flipped up to store taller items like ketchup and bottles of wine on the shelf or in the bin below.

**Foam-in-Place Insulation**

Keeps cold air in and warm air out, helping to maintain temperatures and save energy.

**FreshFlow™ Air Filter**

15 times more powerful than baking soda at reducing common food odors in the refrigerator. Replace every six months.

**FreshFlow™ Produce Preserver**

Helps absorb the ethylene gas that causes fruits and vegetables to over ripen, helping produce stay fresher longer. Replace packet every six months.

**FreshLock™ Crispers**

The full-size design of these crispers provides ample storage for produce. Select crispers also feature humidity control.

**G****Gallon Door Bins**

Sturdy, gallon-size door bins provide a simple solution for storing large items like bottles, jugs and containers. Remove and adjust them for flexible storage needs and easier cleaning.

**H****High-Temperature Alarm**

Monitors the refrigerator and freezer compartments to ensure they don't rise above 50°F or 15°F, respectively. If either compartment rises above the temperature threshold for a specified time, the light on the screen will illuminate until the alarm is reset.

**L****LCD Display**

Easily see settings and options (on select models) with this convenient screen.

**LED Interior Lighting**

These long-lasting lights are engineered to cast a brighter, more natural light so it's easier to see your food. They also use less energy than incandescent lighting.

**M****Measured Fill Option**

This feature accurately dispenses the perfect amount of water in ounces, cups or liters.

**P****Precision Touch Electronic Controls**

Smooth, sleek controls make choices easy with the touch of a button. It's simple to change the interior temperature or get cubed or crushed ice from the dispenser.

**PUR® Water and Ice Filter with Indicator Light**

Reduces contaminants from household water while retaining fluoride, giving you filtered water from your refrigerator for up to six months.† The indicator light lets you know when it's time to change the filter.

**PureChill™ Internal Water Dispenser**

Features a water dispenser inside the refrigerator cabinet for cold, fresh water at any time.

**Q****Quad Cool® Cooling System**

Four thermostats closely monitor the refrigerator and freezer compartments, the ice maker and exterior temperatures to help minimize wide temperature fluctuations.

**R****Ramp-Up LED Lighting**

Ramp-up LED lights reach their full output in stages, for a more premium experience. These LED lights use less energy, produce less heat than incandescent lighting and deliver long-lasting performance.

**Reliable Electronic Touch Controls**

These easy-to-use touchpad electronic controls offer precise temperature adjustment.

**Right Size Ice Cubes**

These smaller ice cubes are more compact than normal ice, making them an ideal fit for refillable water bottles and easier to blend for smoothies.

**S****Sabbath Mode**

Side-by-side models: When activated, all control lights and the night-light will be disabled until the feature is turned off. Bottom-freezer and Ice2O® models: When activated, all control lights, interior lights and alarm tones will be disabled.

**Service Indicator Light**

This light conveniently alerts you when the ice maker unit may need service.

**SmoothClose™ Freezer Drawer Track System**

This dependable drawer design makes storing and accessing frozen food easy. Opens and closes effortlessly and holds up to 120 lbs of food.

**Speed Cool Option**

Speed Cool unleashes a cold blast of air to your refrigerator, giving you an easy way to get your food to the perfect temperature. So you can load up your fridge, then quickly cool it down.

**Spill-Catcher™ Shelves**

Spill-Catcher™ shelves have sleek metal-trimmed edges that help keep leaks and spills from becoming a big mess. Select shelves slide out for convenience.

**Store-N-Door® Ice Dispensing System**

In select french door models the ice bin is in the door for more usable refrigerator storage space and easier access for filling large containers.

**Store-N-Door® Plus Ice Dispensing System**

In select side-by-side models ice production and storage is in the freezer door, creating 30% more usable space, compared to 25 cu. ft. Maytag® side-by-side refrigerators with conventional ice makers.

**Strongbox™ Hinge Design**

Provides structural integrity for the door frame, keeping doors aligned and reducing cold air loss.

**W****Wide-N-Fresh™ Deli Drawer**

This drawer is the ideal size for large party platters, deli trays and snacks. Most models feature temperature controlled drawers.

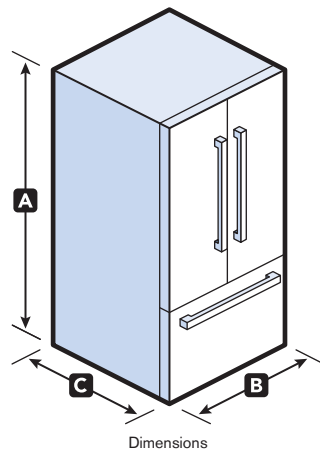

ICE <sub>2</sub> O® FRENCH DOOR MODELS	MFI2269VE	MFI2665XE	MFT2672AE	MFT2976AE	MFX2570AE
<b>DIMENSIONS &amp; SPECIFICATIONS</b>					
Height including hinges (A)	70-1/8"	70-1/8"	70-1/8"	69-15/16"	70-1/8"
Width (B)	32-5/8"	35-5/8"	35-11/16"	35-5/8"	35-5/8"
Depth including handles (C)	34-1/4"	35-1/4"	35-11/16"	35-9/16"	35-5/8"
Height excluding door hinges	68-1/2"	68-5/8"	68-5/8"	68-5/8"	68-5/8"
Depth of cabinet	28"	29"	28-15/16"	28-15/16"	29"
Depth excluding handles	31-7/8"	32-7/8"	33-3/16"	28-15/16"	32-7/8"
Depth w/door open 90°	47"	48"	48"	48"	48"
Approximate shipping weight	350 lbs	375 lbs	352 lbs	352 lbs	298 lbs
<b>CAPACITY</b>					
Freezer volume (cu. ft.)	6.0	6.6	6.8	7.7	6.6
Fresh food volume (cu. ft.)	16.0	19.0	19.4	20.9	18.4
Total shelf area (sq. ft.)	22.4	26.1	25.8	26.8	25.0
Total volume (cu. ft.)	22.0	25.6	26.1	28.6	25.0

FRENCH DOOR MODELS	MFF2055YE	MFF2258VE	MFF2558VE
<b>DIMENSIONS &amp; SPECIFICATIONS</b>			
Height including hinges (A)	68-1/2"	70-1/8"	70-1/8"
Width (B)	29-1/2"	32-5/8"	35-5/8"
Depth including handles (C)	34-5/8"	34-1/2"	35-1/2"
Height excluding door hinges	67-1/2"	68-7/8"	68-7/8"
Depth of cabinet	28-1/2"	28-1/8"	29-1/8"
Depth excluding handles	32-5/16"	32"	33"
Depth w/door open 90°	52-1/2"	47-1/8"	48-1/8"
Approximate shipping weight	255 lbs	350 lbs	350 lbs
<b>CAPACITY</b>			
Freezer volume (cu. ft.)	6.0	5.7	7.3
Fresh food volume (cu. ft.)	13.5	16.1	17.5
Total shelf area (sq. ft.)	19.7	21.5	28.8
Total volume (cu. ft.)	19.5	21.8	24.8



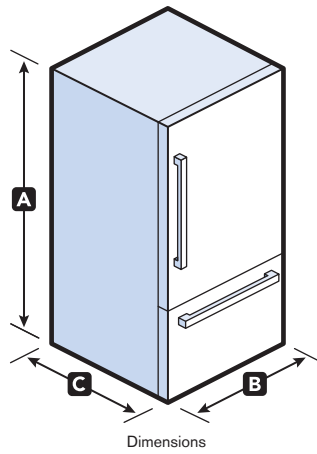

BOTTOM-FREEZER MODELS	MBF1958XE	MBF2258XE	MBR2258XE	MBL2258XE
<b>DIMENSIONS &amp; SPECIFICATIONS</b>				
Height including hinges (A)	66-15/16"	69-15/16"	69-15/16"	69-15/16"
Width (B)	29-5/8"	32-5/8"	32-5/8"	32-5/8"
Depth including handles (C)	33-3/8"	33-3/8"	33-3/8"	33-3/8"
Height excluding door hinges	65-1/2"	68-1/2"	68-1/2"	68-1/2"
Depth of cabinet	28-1/8"	28-1/8"	28-1/8"	28-1/8"
Depth excluding handles	30-7/8"	30-7/8"	30-7/8"	30-7/8"
Depth w/door open 90°	59"	62"	62"	62"
Approximate shipping weight	250 lbs	260 lbs	260 lbs	260 lbs
<b>CAPACITY</b>				
Freezer volume (cu. ft.)	5.6	6.3	6.3	6.3
Fresh food volume (cu. ft.)	12.9	15.6	15.6	15.6
Total shelf area (sq. ft.)	20.0	23.5	23.5	23.5
Total volume (cu. ft.)	18.5	21.9	21.9	21.9

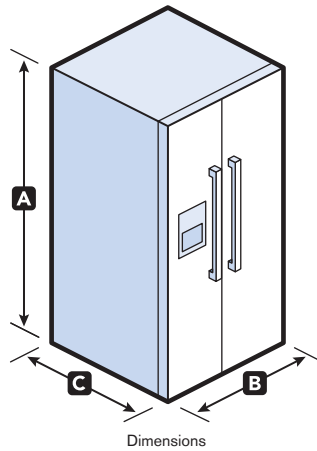

SIDE-BY-SIDE MODELS	MSF22D4XA	MSB27C2XA
<b>DIMENSIONS &amp; SPECIFICATIONS</b>		
Height including hinges (A)	66-1/4"	69"
Width (B)	32-3/4"	35-1/2"
Depth including handles (C)	35"	34"
Height excluding door hinges	65-7/8"	68-1/2"
Depth of cabinet	29-5/8"	29-5/8"
Depth excluding handles	32-3/8"	33-3/4"
Depth w/door open 90°	48-7/8"	50-3/4"
Approximate shipping weight	245 lbs	298 lbs
<b>CAPACITY</b>		
Freezer volume (cu. ft.)	7.4	9.9
Fresh food volume (cu. ft.)	14.6	16.6
Total shelf area (sq. ft.)	22.0	27.1
Total volume (cu. ft.)	22.0	26.5

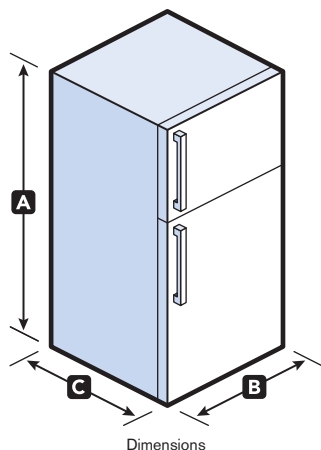

TOP-FREEZER MODELS	M8RXEGMA	M9BXXGMY	M1TXEGMY	M1BXXGMY
<b>DIMENSIONS &amp; SPECIFICATIONS</b>				
Height including hinges (A)	68"	66-1/3"	66-1/4"	66-1/4"
Height excluding door hinges	67-3/8"	65-1/2"	65-1/2"	65-1/2"
Width (B)	28"	29-1/2"	32-1/2"	32-1/2"
Depth including handles (C)	30-3/8"	34"	32-3/4"	34"
Depth of cabinet	26-3/8"	28-1/2"	28-1/2"	28-1/2"
Depth excluding handles	30-3/8"	32-1/2"	30-5/8"	32-1/2"
Depth w/door open 90°	54-3/8"	59-1/4"	62-1/4"	62-1/4"
Approximate shipping weight	225 lbs	183 lbs	205 lbs	205 lbs
<b>CAPACITY</b>				
Freezer volume (cu. ft.)	4.1	5.3	6.2	6.1
Fresh food volume (cu. ft.)	13.5	13.6	14.4	15.0
Total shelf area (sq. ft.)	18.7	18.0	20.8	20.2
Total volume (cu. ft.)	17.5	18.9	20.6	21.0

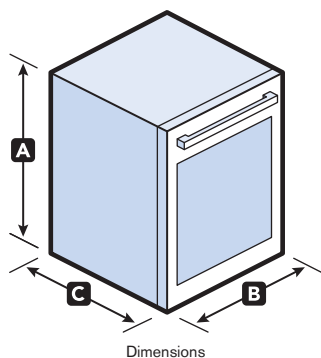

BEVERAGE CENTER	MBCM24FWB
<b>DIMENSIONS &amp; SPECIFICATIONS</b>	
Height (A)	34-5/8" - 35-1/8"
Width (B)	23-3/4"
Depth including handle (C)	26-13/16"
Depth excluding handle	24-3/8"
Depth w/door open 90°	47"
Approximate shipping weight	134 lbs
<b>CAPACITY</b>	
Total shelf area (sq. ft.)	7.9
Total volume (cu. ft.)	5.8

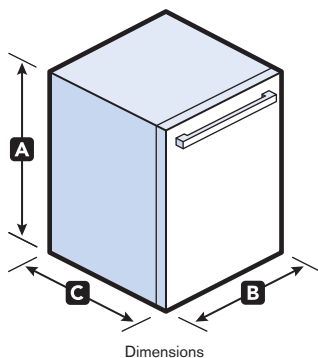

REFRIGERATOR	MURM24FWB
<b>DIMENSIONS &amp; SPECIFICATIONS</b>	
Height (A)	34-5/8" - 35-1/8"
Width (B)	23-3/4"
Depth including handle (C)	26-13/16"
Depth excluding handle	24-3/8"
Depth w/door open 90°	47"
Approximate shipping weight	120 lbs
<b>CAPACITY</b>	
Total shelf area (sq. ft.)	6.7
Total volume (cu. ft.)	5.7

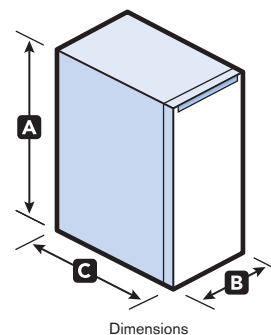

ICE MAKER	MIM1554XR	MIM1555YR
<b>DIMENSIONS &amp; SPECIFICATIONS</b>		
Height (A)	33-5/8" - 34-3/8"	33-5/8" - 34-3/8"
Width (B)	14-7/8"	14-7/8"
Depth including handle (C)	24-3/8"	24-3/8"
Depth excluding handle	23-1/8"	23-1/8"
Depth w/door open 90°	36-7/8"	36-7/8"
Approximate shipping weight	98 lbs	98 lbs

DISHWASHERS

DISHWASHERS



Model shown: MDB8959SAS

# INDUSTRY'S MOST POWERFUL MOTOR AVAILABLE\*

MAYTAG® DISHWASHERS HAVE THE STEELY  
RESOLVE FOR THE WORST KIND OF DIRTY

\*Among leading brands.



Fully Integrated  
Control Dishwashers

**86**



Traditional  
Control Dishwashers

**88**



# Dishwashers



### 2X Life\* Tested Motor

Maytag® dishwashers are Better Built with the industry's most powerful motor available.\*\* These motors have been tested to twice the average dishwasher life expectancy\* to deliver years of dependable cleaning.



### 10-Year Limited Parts Warranty†

The 4-blade stainless steel chopper, nylon racks and stainless steel tub on select dishwashers are all backed by a 10-year limited parts warranty† for dependable, long-lasting performance.



Visit [maytag.com](http://maytag.com) for warranty details.



### Jetclean® Plus Steam Cycle

Cleans everything from your messiest pans to your finest stemware. High pressure spray jets and increased temperatures power off tough, stuck-on food while finishing steam helps clean and reduce spots on glassware.



### 100% Stainless Steel Tub

This attractive, 100% stainless steel tub retains heat from wash and rinse cycles to promote drying of the dishes. The stainless steel tub also cools faster than your dishes, which helps draw moisture to the tub walls, helping prevent spots on glassware and water drops on plastic containers.



### Tiered Upper Rack

With an improved design, this tiered upper rack holds tall items like oversized glassware and 9" plates. Plus, the improved design creates more room in the lower rack, allowing you to vertically place large, 9" x 13" pans for ultimate dish loading flexibility.



**MDB6769PA**  
 Jetclean® Plus dishwasher  
 W/B/S



**NEW MDB8959SB**  
 Jetclean® Plus dishwasher  
 W/B/S



**COLOR OPTIONS**



**W**  
 White

**B**  
 Black

**S**  
 Stainless Steel

**LIMITED PARTS WARRANTY & 30-DAY QUIET GUARANTEE COVERED MODELS**



Visit [maytag.com](http://maytag.com) for warranty details.

**MDB8959SB**



30-Day Quiet Guarantee valid through 12/31/14, visit [maytag.com](http://maytag.com) for details.

**MDB8959SB**



MODELS	MDB6769PA	NEW MODEL MDB8959SB
10-year limited parts warranty* on nylon racks, stainless steel tub and 4-blade stainless steel chopper		•
30-Day Quiet Guarantee**		•
Cycles/Options	6/6	6/7
Easy-close latch	•	•
ENERGY STAR® qualified	•	•
Jetclean® Plus Steam cycle	•	•
Jetclean® Plus wash system	•	•
Oversize Capacity Plus tall tub	•	•
Place setting capacity	14	<b>15</b>
QuietSeries™ sound package	57 dBA†	<b>50 dBA†</b>
Tub interior	Armor Gray	<b>100% Stainless Steel</b>
<b>WASH SYSTEM</b>		
High-pressure spray jets	•	•
Rinse-aid dispenser	•	•
Wash levels	3	3
<b>CONTROL FEATURES</b>		
Automatic temperature control	•	•
Fully integrated controls	•	•
Microprocessor controls with touchpad	•	•
Precision Clean™ turbidity sensor	•	•
<b>CYCLES</b>		
Auto Clean	•	•
Jetclean® Plus Steam	•	•
Light Wash	•	•
Normal Wash	•	•
Quick Wash	•	•
Rinse Only	•	•
<b>OPTIONS</b>		
Control Lock	•	•
Delay Start	2/4/8 Hour	2/4/8 Hour
Extra Dry		•
Heated Dry	•	•
Hi-Temp Wash	•	•
Steam Sanitize	•	•
ToughScrub™	•	
ToughScrub™ Plus		•
<b>RACK FLEXIBILITY</b>		
Adjustable, removable upper rack	•	•
Ball tip rack tines	•	•
High-side lower rack with Stack-Rack shelves		•
Lower rack fold-away tines		•
Premium adjustable upper rack		•
Premium dark DuraGuard® nylon racks	•	•
Premium rack glides		•
Split & Fit™ silverware basket	•	•
Strong Grip tiered upper rack	•	
Upper rack cup shelf	•	•
Upper rack light-item clips		<b>4</b>
<b>BETTER BUILT COMPONENTS</b>		
2X Life†† tested motor	•	•
4-blade stainless steel chopper	•	•
<b>SPECIFICATIONS</b>		
Overall dimensions (height x width x depth excluding handle)	33-7/8" – 34-1/2" x 23-7/8" x 24-1/2"	33-7/8" – 34-1/2" x 23-7/8" x 24-1/2"
Color options	W/B/S	W/B/S

**Bold type indicates step-up feature**

Feature glossary can be found on page 91.  
Complete product specifications can be found on page 92.  
Accessories can be found on page 150.

\*Visit maytag.com for warranty details. \*\*30-Day Quiet Guarantee valid through 12/31/14, visit maytag.com for details.  
†Per IEC standards. ††Twice life testing based on accelerated 20-year life testing, normal cycle, average use.



**MDB4709PA**

Jetclean® Plus dishwasher  
W/Q/B/M



**NEW MDB7749SB**

Jetclean® Plus dishwasher  
W/Q/B/M



**COLOR OPTIONS**



**W**  
White



**Q**  
Bisque



**B**  
Black



**M**  
Monochromatic  
Stainless Steel

**LIMITED PARTS WARRANTY & 30-DAY QUIET GUARANTEE COVERED MODELS**



Visit [maytag.com](http://maytag.com) for warranty details.

**MDB7749SB**



30-Day Quiet Guarantee valid through 12/31/14, visit [maytag.com](http://maytag.com) for details.

**MDB7749SB**

MODELS	MDB4709PA	NEW MODEL MDB7749SB
10-year limited parts warranty* on nylon racks, stainless steel tub and 4-blade stainless steel chopper		•
30-Day Quiet Guarantee**		•
Cycles/Options	5/5	<b>6/6</b>
Easy-close latch	•	•
ENERGY STAR® qualified	•	•
Jetclean® Plus Steam cycle		•
Jetclean® Plus wash system	•	•
Oversize Capacity Plus tall tub	•	•
Place setting capacity	12	<b>13</b>
QuietSeries™ sound package	57 dBA†	<b>50 dBA†</b>
Tub interior	Armor Gray	<b>100% Stainless Steel</b>
<b>WASH SYSTEM</b>		
High-pressure spray jets	•	•
Rinse-aid dispenser	•	•
Wash levels	3	3
<b>CONTROL FEATURES</b>		
2-1/2" Flush console	•	•
Automatic temperature control	•	•
Microprocessor controls with touchpads	•	•
Precision Clean™ turbidity sensor	•	•
<b>CYCLES</b>		
Auto Clean		•
Heavy Wash	•	
Jetclean® Plus Steam		•
Light Wash	•	•
Normal Wash	•	•
Quick Wash	•	•
Rinse Only	•	•
<b>OPTIONS</b>		
Control Lock	•	•
Delay Start	2/4/8 Hour	2/4/8 Hour
Heated Dry	•	•
Hi-Temp Wash	•	•
Steam Sanitize	•	•
ToughScrub™		•
<b>RACK FLEXIBILITY</b>		
Ball tip rack tines	•	•
Premium dark DuraGuard® nylon racks	•	•
Standard silverware basket	•	•
Tiered upper rack	•	•
Upper rack cup shelf	•	•
<b>BETTER BUILT COMPONENTS</b>		
2X Life†† tested motor	•	•
4-blade stainless steel chopper	•	•
<b>SPECIFICATIONS</b>		
Overall dimensions (height x width x depth excluding console)	33-7/8" - 34-1/2" x 23-7/8" x 24-1/2"	<b>33-7/8" - 34-1/2" x 23-7/8" x 24-1/2"</b>
Color options	W/Q/B/M	W/Q/B/M

**Bold type indicates step-up feature**

Feature glossary can be found on page 91.  
Complete product specifications can be found on page 93.  
Accessories can be found on page 150.

\*Visit maytag.com for warranty details. \*\*30-Day Quiet Guarantee valid through 12/31/14, visit maytag.com for details.  
†Per IEC standards. ††Twice life testing based on accelerated 20-year life testing, normal cycle, average use.



**COLOR OPTIONS**



**W**  
White



**B**  
Black

**PORTABLE DISHWASHER**

MODEL	MDC4809PA
Active-door latch system	•
Cycles/Options	5/4
ENERGY STAR® qualified	•
Jetclean® Plus wash system	•
Oversize Capacity Plus tall tub	•
Place setting capacity	10
QuietSeries™ sound package	64 dBA*
Tub interior	White
<b>WASH SYSTEM</b>	
High-pressure spray jets	•
Rinse-aid dispenser	•
Wash levels	2
<b>CONTROL FEATURES</b>	
Automatic temperature control	•
Microprocessor controls with touchpads	•
<b>CYCLES</b>	
1-Hour Wash	•
Heavy Wash	•
Light Wash	•
Normal Wash	•
Rinse Only	•
<b>OPTIONS</b>	
Delay Start	4-Hour
Heated Dry	•
Hi-Temp Wash	•
Sani Rinse	•
<b>RACK FLEXIBILITY</b>	
One-piece, removable silverware basket	•
Vinyl racks	•
<b>BETTER BUILT COMPONENTS</b>	
2X Life** tested motor	•
4-blade stainless steel chopper	•
<b>SPECIFICATIONS</b>	
Overall dimensions (height x width x depth excluding console)	37" x 24" x 26-1/2"
Color options	W/B



**COLOR OPTIONS**



**W**  
White



**B**  
Black



**S**  
Stainless Steel

**TRASH COMPACTOR**

MODEL	MTUC7000AW
1/3-HP motor	•
5-to-1 compaction ratio	•
Bag retainer buttons	•
Capacity (cu. ft.)	1.4
Drawer opener pedal	•
Fan with charcoal filter	•
Front levelers/Rear rollers	•
Plastic bags	•
QuietSeries™ sound package	•
Removable knob	On/Off/Start
Side release bin	•
Solid Pack feature	On/Off
Undercounter	•
Wrap-around drawer panel	•
Zinc-coated frame, base and interior	•
<b>SPECIFICATIONS</b>	
Overall dimensions (height x width x depth excluding console)	34-1/8" – 34-1/2" x 15" x 24"
Color options	W/B/S

NOTE: The portable dishwasher's side panel color matches the color of the front panel.

\*Per IEC standards. \*\*Twice life testing based on accelerated 20-year life testing, normal cycle, average use.

Accessories can be found on page 150.

**#****10-Year Limited Parts Warranty<sup>†</sup>**

Some Maytag<sup>®</sup> dishwashers are backed by a 10-year limited parts warranty<sup>†</sup> on the nylon racks, stainless steel tub and 4-blade stainless steel chopper for long-lasting performance.

**100% Stainless Steel Tub**

This attractive, 100% stainless steel tub retains heat from wash and rinse cycles to promote drying of the dishes. The stainless steel tub also cools faster than your dishes, which helps draw moisture to the tub walls, helping prevent spots on glassware and water drops on plastic containers.

**2X Life Tested<sup>††</sup> Motor**

Maytag<sup>®</sup> dishwasher motors have been tested to twice the average dishwasher life expectancy<sup>††</sup> to deliver years of dependable cleaning.

**30-Day Quiet Guarantee<sup>‡</sup>**

If customers are not completely satisfied that their new dishwasher is quieter than their previous model, select models may be returned within 30 days of the date of purchase for a full refund.<sup>‡</sup>

**A****Adjustable and Removable Racks**

The racks can be adjusted to customize each load or completely removed for washing oversized items in the lower rack.

**Armor Gray Tub Interior**

Gray, durable plastic interior reduces the appearance of stains to keep the dishwasher looking clean longer.

**Auto Clean Cycle**

Gauges the soil level of the load, then automatically adjusts temperature, wash time and the number of fills accordingly for optimal cleaning without overusing resources.

**B****Ball Tip Rack Tines**

Rounded tips are gentle on dishes, helping to prevent them from being scratched.

**Better Built Components**

Select Maytag<sup>®</sup> dishwashers feature a 2X Life<sup>††</sup> tested motor and a stainless steel chopper blade that are Better Built to provide the enhanced performance Maytag brand is known for.

**C****Control Lock**

When activated, this feature prohibits unwanted changes from occurring due to accidental operation.

**D****Delay Start Option**

Automatically starts the dishwasher at a later time to accommodate your schedule and take advantage of reduced energy rates where available.

**E****ENERGY STAR<sup>®</sup> Qualification**

An ENERGY STAR<sup>®</sup> qualification means the dishwasher exceeds the federal minimum efficiency standards as set forth by the Environmental Protection Agency and the U.S. Department of Energy, helping save money on utility bills.

**Extra Dry Option**

Extends drying time by 20 minutes for 20% better drying performance versus normal cycle with heated dry.

**F****Fold-Away Tines**

Securely holds plates and bowls in place or folds flat to make room for larger items.

**Fully Integrated Controls**

This durable control panel is tucked away, providing a strong, sleek exterior that lowers the possibility of unintended use.

**H****Heated Dry Option**

Allows you to select a drying cycle that includes heat so dishes are dry when you put them away.

**Hi-Temp Wash Option**

Adds an extra rinse and elevates the temperature to 145°F by the end of the rinse cycle to help reduce water spots and remove any remaining particles.

**High-Pressure Spray Jets**

Creates increased water pressure to remove tough food particles.

**High-Side Lower Rack**

Holds two 9" x 13" pans in an upright position for greater loading flexibility.

**J****Jetclean<sup>®</sup> Plus Steam Cycle**

Cleans everything from your messiest pans to your finest stemware. High pressure spray jets and increased temperatures power off tough, stuck-on food while finishing steam helps clean and reduce spots on glassware.

**Jetclean<sup>®</sup> Plus Wash System**

Uses high-pressure spray jets to remove tough food particles. A stainless steel chopper blade pulverizes food, preventing particles from plugging the wash system and spray jets. The filtration system captures tiny food particles to prevent redistribution.

**L****Light-Item Clips**

Located in the upper rack, the curved clips provide gentle tension against the tine to secure lightweight items.

**P****Precision Clean<sup>™</sup> Turbidity Sensor**

Detects food soil, detergent, rinse aid and temperature. Adjusts to deliver optimum washing and rinsing action for superb cleaning results.

**Premium Dark DuraGuard<sup>®</sup> Nylon Racks**

These heavy-duty racks help protect dishes from scratches and damage while resisting rust.

**Premium Rack Glides**

Premium rack glides allow you to slide out the upper rack effortlessly, even under the weight of heavy dishes or baking pans.

**Q****QuietSeries<sup>™</sup> Sound Packages**

Specially designed sound absorbers and dampeners reduce noise for quieter operation and less household disruption.

**S****Split & Fit<sup>™</sup> Silverware Basket**

This silverware basket can be divided into two halves to fit almost any situation.

**Stainless Steel Chopper**

Pulverizes the food particles that come off your plates so they don't end up recirculating and sticking to your dishes.

**Steam Sanitize Option**

Sanitizes dishes with a high-temperature rinse that reduces 99.999% of food soil bacteria, then adds the finishing touch of steam.

**Strong Grip Tiered Upper Rack**

With an improved design, this rack makes room for tall items while providing easy access and a modern look with the durability and strength Maytag brand is known for.

**T****Tiered Upper Rack**

With an improved design, this upper rack holds tall items like 9" plates and glasses. It also creates enough room in the lower rack to vertically place two 9" x 13" pans.

**ToughScrub<sup>™</sup> and ToughScrub<sup>™</sup> Plus Options**

The ToughScrub<sup>™</sup> option maintains or raises the temperature to 145°F and increases wash time to power off dried-on, baked-on food. The ToughScrub<sup>™</sup> Plus option maintains or raises the temperature to 156°F and also incorporates steam as an added attack against difficult food soils.

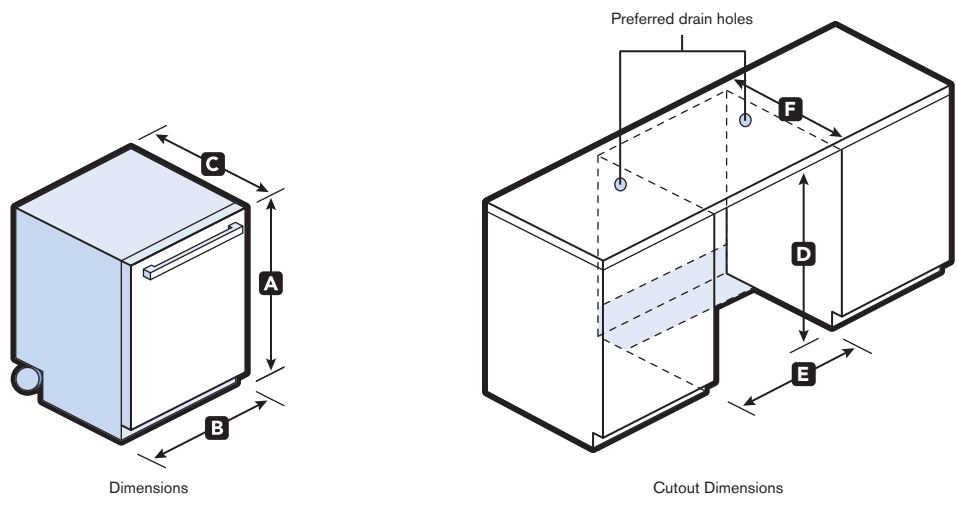

MODELS	MDB6769PA	MDB8959SB
<b>DIMENSIONS &amp; SPECIFICATIONS</b>		
Height (A)	33-7/8" – 34-1/2"	33-7/8" – 34-1/2"
Width (B)	23-7/8"	23-7/8"
Depth including handle (C)	27-1/2"	27-1/2"
Depth excluding handle	24-1/2"	24-1/2"
Approximate shipping weight	85 lbs	103 lbs
Volts (amps) required	120 (15)	120 (15)
<b>CUTOUT DIMENSIONS</b>		
Minimum height (D)	34"	34"
Width (E)	24"	24"
Depth (F)	24"	24"
<b>CYCLES</b>		
Auto Clean	•	•
Jetclean® Plus Steam	•	•
Light Wash	•	•
Normal Wash	•	•
Quick Wash	•	•
Rinse Only	•	•
<b>OPTIONS</b>		
Control Lock	•	•
Delay Start	2/4/8 Hour	2/4/8 Hour
Extra Dry	•	•
Heated Dry	•	•
Hi-Temp Wash	•	•
Steam Sanitize	•	•
ToughScrub™	•	•
ToughScrub™ Plus		•

**Bold type indicates step-up feature**

Dimensions shown are for planning purposes only. See Installation Instructions packed with product for complete information.

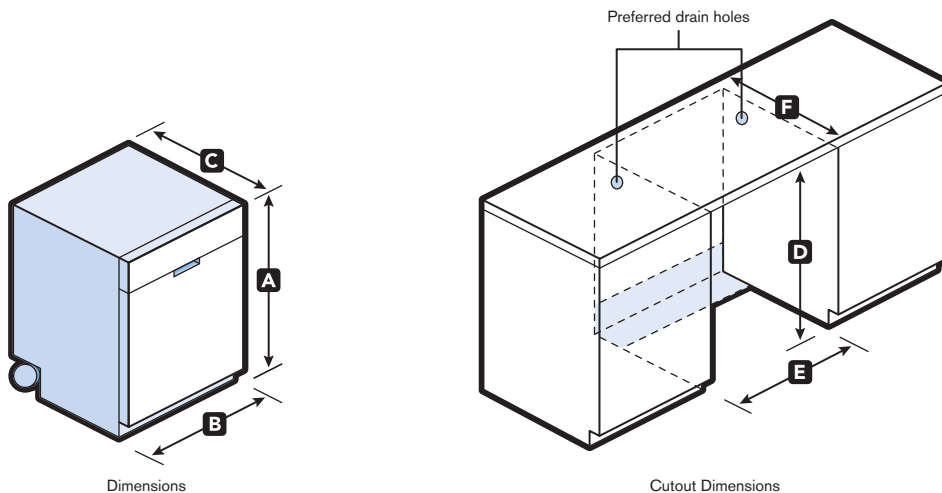

MODELS	MDB4709PA	MDB7749SB
<b>DIMENSIONS &amp; SPECIFICATIONS</b>		
Height (A)	33-7/8" – 34-1/2"	33-7/8" – 34-1/2"
Width (B)	23-7/8"	23-7/8"
Depth including console (C)	25-1/2"	25-1/2"
Depth excluding console	24-1/2"	24-1/2"
Approximate shipping weight	85 lbs	92 lbs
Volts (amps) required	120 (15)	120 (15)
<b>CUTOUT DIMENSIONS</b>		
Minimum height (D)	34"	34"
Width (E)	24"	24"
Depth (F)	24"	24"
<b>CYCLES</b>		
Auto Clean		•
Heavy Wash	•	
Jetclean® Plus Steam		•
Light Wash	•	•
Normal Wash	•	•
Quick Wash	•	•
Rinse Only	•	•
<b>OPTIONS</b>		
Control Lock	•	•
Delay Start	2/4/8 Hour	2/4/8 Hour
Heated Dry	•	•
Hi-Temp Wash	•	•
Steam Sanitize	•	•
ToughScrub™		•

**Bold type indicates step-up feature**

COOKING



COOKING

Model shown: MIT8795BS



# TWICE THE COOKING CONVENIENCE

MAYTAG® DOUBLE OVENS HAVE THE CAPACITY AND POWER TO REDEFINE FAST FOOD



Gemini® Double Oven Ranges  
**96**



Freestanding Ranges  
**102**



Microwaves  
**108**



Wall Ovens  
**114**



Cooktops  
**122**



**Gemini<sup>®</sup>**  
Double Oven Ranges



### Induction Cooking Technology

Induction brings the speed of a gas range to a cooktop that is sleek and easy to clean. It heats the pan, not the surrounding cooktop, which makes cleanup easier and ultra efficient, too. Best of all, it rapidly and precisely delivers heat, speeding cooking so you'll have more time to enjoy the food you love.



### Power Preheat

Gemini® electric ranges combine the power of the bake and broil elements, convection fan and Power Vents to preheat up to 40% faster than full-size conventional Maytag® ovens.\*

**PowerPreheat**



### 10-Year Limited Parts Warranty\*\*

Components covered by this 10-year limited parts warranty\*\* include electric oven and cooktop elements and the glass cooktop, as well as the gas oven and cooktop burners and die-cast metal grates.



Visit [maytag.com](http://maytag.com) for warranty details.



### Power Center Cooktops

Power Center cooktops include a versatile configuration of four or five cooktop elements or burners built to provide the power and flexibility you've come to expect from Maytag brand.

**PowerCenter**  
ELECTRIC COOKTOP

**PowerCenter**  
INDUCTION COOKTOP

**PowerCenter**  
GAS COOKTOP



### EvenAir™ True Convection with Third Element and Auto Conversion

With EvenAir™ true convection, you'll be able to roast up to 30% faster than a conventional oven, while getting outstanding baking performance. Plus, Auto Conversion converts standard time and temperatures to their convection equivalents, making sure your legendary family recipes come out perfect.



**MET8665X**  
6.7 cu. ft. total capacity  
W/B/S



**NEW MET8776B**  
6.7 cu. ft. total capacity  
W/B/S

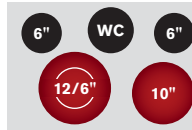

**MET8885X**  
6.7 cu. ft. total capacity  
W/B/S

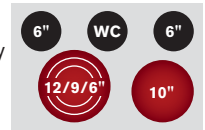

**NEW MIT8795B**  
6.7 cu. ft. total capacity  
Induction Range  
S

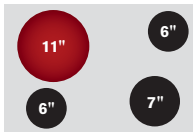

MODELS	NEW MODEL			NEW INDUCTION MODEL
	MET8665X	MET8776B	MET8885X	MIT8795B
10-year limited parts warranty* on the ceramic glass cooktop, cooktop elements and oven elements	•	•	•	•
<b>OVEN FEATURES</b>				
Auto-lock self-cleaning ovens with adjustable levels (both ovens)	•	•	•	•
Capacity - total (cu. ft.)	6.7	6.7	6.7	6.7
Upper oven (cu. ft.)	2.5	2.5	2.5	2.5
Lower oven (cu. ft.)	4.2	4.2	4.2	4.2
Control lockout	•	•	•	•
EvenAir™ convection (lower oven)		•		
EvenAir™ true convection with third element (lower oven)			•	•
Hidden bake element with Power Vents		•	•	•
High/low variable broil (both ovens)	•	•	•	•
Oven rack positions	2 Upper/5 Lower	2 Upper/5 Lower	2 Upper/5 Lower	2 Upper/5 Lower
Upper oven	1 Standard	1 Standard	1 Standard	1 Standard
Lower oven	2 Standard	2 Standard	2 Standard	<b>1 Heavy-duty/1 Heavy-duty rollout</b>
Power Preheat	•	•	•	•
Precision Cooking™ system with Precise Preheat, Precise Bake and Precise Broil (both ovens)	•	•	•	•
Sabbath Mode	•	•	•	•
<b>POWER CENTER FEATURES</b>				
6", 1,800-watt induction element				<b>LF, RR</b>
7", 2,500-watt induction element				<b>RF</b>
9"/6", 3,000/1,400-watt Dual-Choice™ radiant element	LF			
10", 3,200-watt Speed Heat™ radiant element	RF	RF	RF	
11", 3,700-watt Speed Heat™ induction element				<b>LR</b>
12"/6", 2,700/1,050-watt Dual-Choice™ radiant element		<b>LF</b>		
12"/9"/6", 2,700/1,950/1,050-watt Triple-Choice™ radiant element			<b>LF</b>	
<b>COOKTOP FEATURES</b>				
6", 700-watt radiant element	RR	LR	RR	
6", 1,200-watt radiant element	LR	RR	LR	
100-watt Precision Warming™ center	Center	Center	Center	
Hot surface indicator light	•	•	•	
<b>CONTROL FEATURES</b>				
Display readout	Amber	Amber	Amber	Amber
Keep Warm™ and Delay Bake/Clean settings	•	•	•	•
Reliable electronic touch oven controls	•	•	•	•
<b>EXTERIOR FEATURES</b>				
DuraClean™ smooth-gloss backguard	•	•	•	•
Glass-front oven doors**	•	•	•	•
Stainless steel-wrapped backguard†	•	•	•	•
<b>BETTER BUILT COMPONENTS</b>				
Durable metal door handles†	•	•	•	•
Heavy-duty door hinges	•	•	•	•
Heavy-duty racks				•
Shatter-resistant cooktop	•	•	•	•
<b>SPECIFICATIONS</b>				
Overall dimensions (height x width x depth including handles)	47-1/8" x 29-15/16" x 28-1/2"	47-7/8" x 29-15/16" x 28-1/2"	47-1/8" x 29-15/16" x 28-1/2"	47-7/8" x 29-15/16" x 28-1/2"
Color options	W/B/S	W/B/S	W/B/S	S

**Bold type indicates step-up feature**

**COLOR OPTIONS**



**W**  
White



**B**  
Black



**S**  
Stainless Steel

**LIMITED PARTS WARRANTY COVERED MODELS**



Visit [maytag.com](http://maytag.com) for warranty details.

**MET8665X MET8885X  
MET8776B MIT8795B**

Feature glossary can be found on page 134.  
Complete product specifications can be found on page 136.  
Accessories can be found on page 152.

\*\*Stainless steel models have chamfered door edges. †Stainless steel models only.  
\*Visit [maytag.com](http://maytag.com) for warranty details.



**MGT8655X**

6.0 cu. ft. total capacity

W/B/S

5,000 BTU	9,200 BTU
15,000 BTU	9,200 BTU



**MGT8775X**

6.0 cu. ft. total capacity

W/B/S

5,000 BTU	9,200 BTU
16,000 BTU	9,200 BTU



**MGT8885X**

6.0 cu. ft. total capacity

W/B/S

5,000 BTU	7,350 BTU	5,000 BTU
16,000 BTU	10,000 BTU	



MODELS	MGT8655X	MGT8775X	MGT8885X
10-year limited parts warranty* on the die-cast metal grates, oven burners and cooktop burners	•	•	•
<b>OVEN FEATURES</b>			
Auto-lock self-cleaning ovens with adjustable levels (both ovens)	•	•	•
Capacity - total (cu. ft.)	6.0	6.0	6.0
Upper oven (cu. ft.)	2.1	2.1	2.1
Lower oven (cu. ft.)	3.9	3.9	3.9
Closed-door broiling (upper oven)	•	•	•
Control lockout	•	•	•
EvenAir™ convection (lower oven)	•	•	•
EvenAir™ true convection with third element (lower oven)			•
Hidden bake burner	•	•	•
High/low variable broil (upper oven)	•	•	•
Oven rack positions	2 Upper/5 Lower	2 Upper/5 Lower	2 Upper/5 Lower
Upper oven	1 Standard	1 Standard	1 Standard
Lower oven	2 Standard	2 Standard	2 Standard
Power Preheat	•	•	•
Precision Cooking™ system with Precise Preheat, Precise Bake and Precise Broil (both ovens)	•	•	•
Sabbath Mode	•	•	•
<b>POWER CENTER FEATURES</b>			
7,350-BTU Griddle burner (griddle included)			<b>Center</b>
15,000-BTU Power Cook burner	LF		
16,000-BTU Speed Heat™ burner		<b>LF</b>	LF
<b>COOKTOP FEATURES</b>			
5,000-BTU 5th burner		<b>Center</b>	
5,000-BTU burner	LR	LR	LR, RR
9,200-BTU burner	RR, RF	RR, RF	
10,000-BTU burner			<b>RF</b>
DuraClean™ die-cast metal burner grates	Full-width	Full-width	Full-width
DuraClean™ lift-off burner caps	•	•	•
Sealed surface burners	•	•	•
<b>CONTROL FEATURES</b>			
Display readout	Amber	Amber	Amber
Electronic ignition	•	•	•
Keep Warm™ and Delay Bake/Clean settings	•	•	•
Reliable electronic touch oven controls	•	•	•
<b>EXTERIOR FEATURES</b>			
DuraClean™ smooth-gloss backguard	•	•	•
Glass-front oven doors**	•	•	•
Stainless steel-wrapped backguard†	•	•	•
<b>BETTER BUILT COMPONENTS</b>			
Die-cast metal burner grates	•	•	•
Durable metal door handles†	•	•	•
Heavy-duty door hinges	•	•	•
Heavy-duty racks	•	•	•
<b>SPECIFICATIONS</b>			
Overall dimensions (height x width x depth including handles)	47-1/8" x 29-15/16" x 28-1/2"	47-1/8" x 29-15/16" x 28-1/2"	47-1/8" x 29-15/16" x 28-1/2"
Color options	W/B/S	W/B/S	W/B/S

**Bold type indicates step-up feature**

**COLOR OPTIONS**



**W**  
White



**B**  
Black



**S**  
Stainless Steel

**LIMITED PARTS WARRANTY COVERED MODELS**



Visit [maytag.com](http://maytag.com) for warranty details.

**MGT8655X**  
**MGT8775X**  
**MGT8885X**

Feature glossary can be found on page 134.  
Complete product specifications can be found on page 136.  
Accessories can be found on page 152.

NOTE: All gas ranges can be converted for use with LP gas.  
\*Visit [maytag.com](http://maytag.com) for warranty details. \*\*Stainless steel models have chamfered door edges. †Stainless steel models only.



# Freestanding

Ranges





### Large Capacity Oven

When a surprise visit turns the family dinner into a reunion, there's no need to worry. With 6.2 cu. ft. capacity, there's plenty of space for a main course on the lower rack and a couple side dishes above. Cooking big has never been so easy.



### 10-Year Limited Parts Warranty\*

Components covered by this 10-year limited parts warranty\* include electric oven and cooktop elements and the ceramic glass cooktop, as well as the gas oven and cooktop burners and die-cast metal grates.



Visit [maytag.com](http://maytag.com) for warranty details.

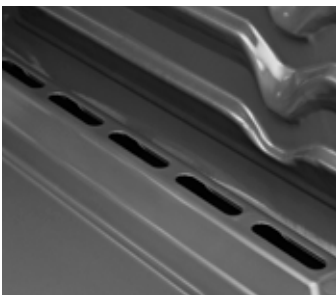

### Power Preheat

By combining the power of the bake and broil burners, convection fan and Power Vents, gas ovens preheat in just 6 minutes and electric in 8 minutes.\*\* This way, your meals can get to the table quicker.



### Power Center Cooktops

Power Center cooktops include a versatile configuration of four or five elements or burners built to provide the power and flexibility you've come to expect from Maytag brand.



### AquaLift® Self-Cleaning Technology

Get your oven clean in less than an hour with odor-free, low temperature AquaLift® self-cleaning technology. This innovative coating on the oven interior activates with water and heat to release tough baked-on soils from underneath so food and debris easily wipe away. Temperatures stay below 200°F as compared to ovens that require heat of up to 800°F during the self-cleaning cycle.



NOTE: Not all features are available on all models. \*Visit [maytag.com](http://maytag.com) for warranty details. \*\*Based on single rack baking with Power Preheat option vs. three-rack baking without option selected.



**NEW MER7685B**

5.3 cu. ft. capacity  
W/B/S

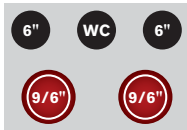

**NEW MER8680B**

6.2 cu. ft. capacity  
W/B/S

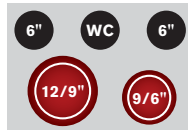

**MER8775A**

6.2 cu. ft. capacity  
W/B/S

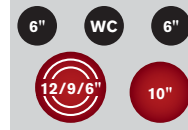

**MER8880A**

6.2 cu. ft. capacity  
W/B/S

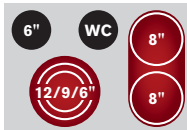

**MIR8890A**

6.2 cu. ft. capacity  
Induction Range  
S

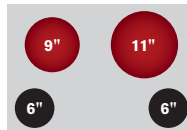

MODELS	NEW MODELS				INDUCTION RANGE
	MER7685B	MER8680B	MER8775A	MER8880A	MIR8890A
10-year limited parts warranty* on the ceramic glass cooktop, cooktop elements and oven elements		•	•	•	•
<b>OVEN FEATURES</b>					
AquaLift™ self-cleaning technology		•	•	•	•
Auto Convection Conversion				•	•
Automatic oven light	•	•	•	•	•
Capacity (cu. ft.)	5.3	<b>6.2</b>	6.2	6.2	6.2
Control lockout	•	•	•	•	•
EvenAir™ convection			•		
EvenAir™ true convection with third element				•	•
Hidden bake element	•				
Hidden bake element with power vents		•	•	•	•
Max capacity rack	•	•	•	•	•
Oven racks	2	2	<b>3</b>	3	3
Panoramic view oven window		•	•	•	•
Power Preheat				•	•
Precision Cooking™ system with Precise Preheat, Precise Bake and Precise Broil	•	•	•	•	•
Sabbath Mode	•	•	•	•	•
Variable broil	•	•	•	•	•
<b>POWER CENTER FEATURES</b>					
6", 1,800-watt induction element					<b>LF, RF</b>
8", 1800-watt radiant element				<b>RF, RR</b>	
9", 3,200-watt Speed Heat™ induction element					<b>LR</b>
9"/6", 3,000/1,400-watt Dual-Choice™ radiant element	LF, RF	RF			
10", 3,200-watt Speed Heat™ radiant element			<b>RF</b>		
11", 3,700-watt Speed Heat™ induction element					<b>RR</b>
12"/9", 3,000/1,900-watt Dual-Choice™ radiant element		<b>LF</b>			
12"/9"/6", 3,000/2,200/1,100-watt Triple-Choice™ radiant element			<b>LF</b>	LF	
800-watt bridge radiant element				<b>Right</b>	
<b>COOKTOP FEATURES</b>					
6", 1,200-watt radiant element	RR, LR	RR, LR	RR		
6", 300/1,300-watt melt element			<b>LR</b>	LR	
100-watt Precision Warming™ center	Center	Center	Center		
Hot surface indicator light	•	•	•	•	•
Induction cooktop					•
<b>CONTROL FEATURES</b>					
Display readout	Amber	Amber	Amber	Amber	Amber
Electronic clock with timer	•	•	•	•	•
Keep Warm™ and Delay Bake settings		•	•	•	•
Reliable electronic touch oven controls	•	•	•	•	•
<b>EXTERIOR FEATURES</b>					
Stainless steel-wrapped backguard**	•	•	•	•	•
Storage drawer	•	•	•	•	•
Warming drawer with handle					•
<b>BETTER BUILT COMPONENTS</b>					
Durable metal door handle**	•	•	•	•	•
Durable metal door hinges	•	•	•	•	•
Shatter-resistant cooktop	•	•	•	•	•
<b>SPECIFICATIONS</b>					
Overall dimensions (height x width x depth including handle)	46-7/8" x 29-7/8" x 27-1/2"	46-7/8" x 29-7/8" x 27-3/4"	46-7/8" x 29-7/8" x 27-3/4"	46-7/8" x 29-7/8" x 27-3/4"	46-7/8" x 29-7/8" x 27-3/4"
Color options	W/B/S	W/B/S	W/B/S	W/B/S	S

**Bold type indicates step-up feature**

**COLOR OPTIONS**



**W**  
White



**B**  
Black



**S**  
Stainless Steel

**LIMITED PARTS WARRANTY COVERED MODELS**



Visit [maytag.com](http://maytag.com) for warranty details.

**MER8680B** **MER8880A**  
**MER8775A** **MIR8890A**

Feature glossary can be found on page 134.  
Complete product specifications can be found on page 137.  
Accessories can be found on page 152.

\*Visit [maytag.com](http://maytag.com) for warranty details. \*\*Stainless Steel models only.



**MGR7685A**  
5.0 cu. ft. capacity  
W/B/S

9,500 BTU	5,000 BTU
15,000 BTU	15,000 BTU



**MGR8670A**  
5.8 cu. ft. capacity  
W/B/S

9,500 BTU	5,000 BTU
15,000 BTU	15,000 BTU



**MGR8674A**  
5.8 cu. ft. capacity  
W/B/S

9,500 BTU	5,000 BTU
17,000 BTU	15,000 BTU



**MGR8775A**  
5.8 cu. ft. capacity  
W/B/S

9,500 BTU	5,000 BTU
17,000 BTU	15,000 BTU



**MGR8880A**  
5.8 cu. ft. capacity  
W/B/S

9,500 BTU	5,000 BTU
17,000 BTU	15,000 BTU



MODELS	MGR7685A	MGR8670A	MGR8674A	MGR8775A	MGR8880A
10-year limited parts warranty* on the die-cast metal grates, oven burners and cooktop burners		•	•	•	•
<b>OVEN FEATURES</b>					
AquaLift™ self-cleaning technology		•	•	•	•
Auto Convert Conversion					•
Automatic oven light	•	•	•	•	•
Capacity (cu. ft.)	5.0	<b>5.8</b>	5.8	5.8	5.8
Control lockout	•	•	•	•	•
EvenAir™ convection				•	
EvenAir™ true convection with third element					•
Max capacity rack	•	•	•	•	•
Oven racks	2	2	2	<b>3</b>	3
Panoramic view oven window		•	•	•	•
Power Preheat					•
Precision Cooking™ system with Precise Preheat, Precise Bake and Precise Broil	•	•	•	•	•
Sabbath Mode	•	•	•	•	•
Variable broil	•	•	•	•	•
<b>POWER CENTER FEATURES</b>					
15,000-BTU Power Cook burner	LF, RF	LF, RF	RF	RF	RF
17,000-BTU Speed Heat™ burner			<b>LF</b>	LF	LF
Integrated griddle system (griddle included)					•
<b>COOKTOP FEATURES</b>					
5,000-BTU Flex-Choice™ simmer burner	RR	RR	RR	RR	RR
8,000-BTU 5th burner			<b>Center</b>	Center	Center
9,500-BTU burner	LR	LR	LR	LR	LR
DuraClean™ die-cast metal burner grates	•	•	•	•	•
Sealed surface burners	•	•	•	•	•
Upswept porcelain cooktop	•	•	•	•	•
<b>CONTROL FEATURES</b>					
Display readout	Amber	Amber	Amber	Amber	Amber
Electronic clock with timer	•	•	•	•	•
Keep Warm™ and Delay Bake settings	•	•	•	•	•
Reliable electronic touch oven controls	•	•	•	•	•
<b>EXTERIOR FEATURES</b>					
Stainless steel-wrapped backguard**	•	•	•	•	•
Storage drawer	•	•	•	•	•
<b>BETTER BUILT COMPONENTS</b>					
Die-cast metal grates	•	•	•	•	•
Durable metal door handle**	•	•	•	•	•
Durable metal door hinges	•	•	•	•	•
<b>SPECIFICATIONS</b>					
Overall dimensions (height x width x depth including handle)	46-7/8" x 29-7/8" x 27-9/16"	46-7/8" x 29-7/8" x 27-7/8"	46-7/8" x 29-7/8" x 27-7/8"	46-7/8" x 29-7/8" x 27-7/8"	46-7/8" x 29-7/8" x 27-7/8"
Color options	W/B/S	W/B/S	W/B/S	W/B/S	W/B/S

**Bold type indicates step-up feature**

**COLOR OPTIONS**



**W**  
White



**B**  
Black



**S**  
Stainless Steel

**LIMITED PARTS WARRANTY COVERED MODELS**



Visit [maytag.com](http://maytag.com) for warranty details.

**MGR8670A MGR8775A**  
**MGR8674A MGR8880A**

Feature glossary can be found on page 134.  
Complete product specifications can be found on page 137.  
Accessories can be found on page 152.

NOTE: All gas ranges can be converted for use with LP gas.  
\*Visit [maytag.com](http://maytag.com) for warranty details. \*\*Stainless Steel models only.



# Microwaves

Countertop and Over-the-Range

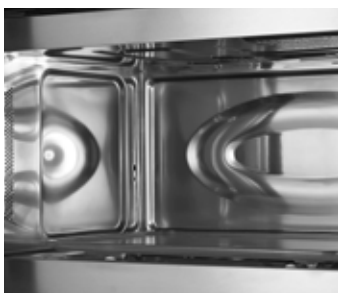

### Better Built Components

With a stainless steel interior, hidden vent and stainless finish handle,\* these microwaves provide a premium look and feature components that are built to last.



### 2.0 cu. ft. Capacity

Select microwave models can easily fit a 10" x 15" pan, so there's plenty of space to cook whatever you want—a large lasagna, a roast, side dishes and more.



### WideGlide™ Tray

Entire family meals like casseroles cook evenly every time by moving back and forth within the spacious 2.0 cu. ft. interior. The WideGlide™ tray not only moves, but provides plenty of room for large pans. This allows the flexibility for multiple dishes or one large piece of cookware like a 10" x 15" pan to cook all your family's favorites.



### Sensor Cooking Options

Cook a wide range of foods with microwave sensors that monitor and automatically adjust cooking time and power as needed.



### 10-Year Limited Parts Warranty\*\*

Select Maytag® over-the-range microwaves are backed by a 10-year limited parts warranty\*\* on the magnetron for dependable, long-lasting performance. The magnetron generates the energy needed to heat food. Without it, your microwave won't work, which is why Maytag brand covers it for 10 years.



Visit [maytag.com](http://maytag.com) for warranty details.



**UMC5165A**  
1.6 cu. ft. capacity  
Countertop Microwave  
W/B/S



**MMV1164W**  
1.6 cu. ft. capacity  
Over-the-Range Microwave  
W/B/S



**MMV4203W**  
2.0 cu. ft. capacity  
Over-the-Range Microwave  
W/B/S

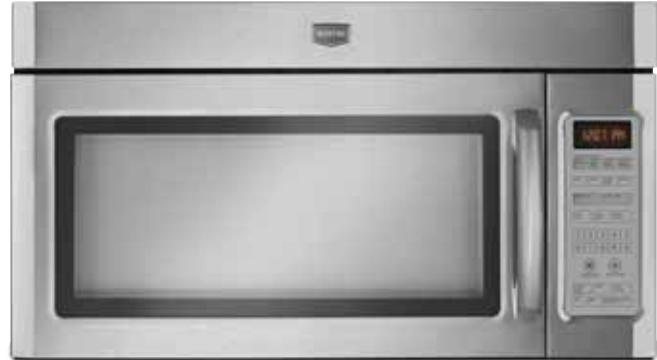

**NEW MMV4206B**  
2.0 cu. ft. capacity  
Over-the-Range Microwave  
W/B/S



**MMV5208W**  
2.0 cu. ft. capacity  
Over-the-Range Microwave  
W/B/S



**MMV6180W**  
1.8 cu. ft. capacity  
Over-the-Range Microwave  
W/B/S



	COUNTERTOP MODEL			NEW MODEL		
MODELS	UMC5165A	MMV1164W	MMV4203W	MMV4206B	MMV5208W	MMV6180W
10-year limited parts warranty* on magnetron				•	•	•
<b>OVEN FEATURES</b>						
Capacity (cu. ft.)	1.6	1.6	<b>2.0</b>	2.0	2.0	1.8
Charcoal odor filter		•	•	•	•	•
Control lockout	•	•	•	•	•	•
Cooktop light timer			•	•	•	•
Delay-Stop fan settings					•	•
Display readout	Amber	Amber	Amber	Amber	Amber	Amber
Display with digital clock	•	•	•	•	•	•
Ductless or optional outside venting		•	•	•	•	•
Filter indicator message				•	•	•
Incandescent cooktop light		•	•	•	•	•
Interior cooking rack			•	•	•	•
Interior light	•	•	•	•	•	•
Mesh grease filter		•	•	•	•	•
Microwave power output (watts)	1,200	1,000	1,000	1,000	1,000	1,000
Precision Cooking™ system	•	•	•	•	•	•
Reliable electronic touch controls	•	•	•	•	•	•
Turntable	•	•	•	•	<b>WideGlide™</b>	•
Variable power levels	10	10	10	10	10	10
Ventilation system		<b>2-speed, 220-CFM fan</b>	<b>3-speed, 300-CFM fan</b>	3-speed, 300-CFM fan	<b>4-speed, 300-CFM fan</b>	<b>5-speed, 300-CFM fan</b>
<b>COOKING OPTIONS</b>						
Add 1 Minute		•				
Add 30 Seconds	•		•	•	•	•
Auto Cook		•	•	•	•	•
Auto Defrost	•	•	•	•	•	•
Auto Reheat		•	•	•	•	•
Baked Potato	•	•	•	•	•	•
Casserole		•	•	•	•	•
Dinner Plate	•	•	•	•	•	•
EvenAir™ convection						•
Frozen Entrée	•	•	•	•	•	•
Kids Meals			•	•	•	•
Pizza	•	•	•	•	•	•
Popcorn	•	•	•	•	•	•
Sensor cooking options	•			•	•	•
Sensor Reheat				•	•	•
Snacks			•	•	•	•
Soften/Melt			•	•	•	•
<b>BETTER BUILT COMPONENTS</b>						
Flush hidden vent		•	•	•	•	•
Stainless finish handle**		•	•	•	•	•
Stainless steel interior				•	•	•
<b>SPECIFICATIONS</b>						
Overall dimensions (height x width x depth including handle)	13" x 21-3/4" x 17-1/4"	17-1/4" x 29-15/16" x 17-3/4"	17-1/4" x 29-15/16" x 17-3/4"	17-1/4" x 29-15/16" x 17-3/4"	17-1/4" x 29-15/16" x 17-3/4"	17-1/4" x 29-15/16" x 17-3/4"
Color options	W/B/S	W/B/S	W/B/S	W/B/S	W/B/S	W/B/S

**Bold type indicates step-up feature**

**COLOR OPTIONS**



**W**  
White



**B**  
Black



**S**  
Stainless Steel

**LIMITED PARTS WARRANTY COVERED MODELS**



**MMV4206B**  
**MMV5208W**  
**MMV6180W**

Visit [maytag.com](http://maytag.com) for warranty details.

Feature glossary can be found on page 134.  
Complete product specifications can be found on page 138.  
Accessories can be found on page 152.

\*Visit [maytag.com](http://maytag.com) for warranty details. \*\*Stainless steel models only.



## FIT system

# REVOLUTIONIZING WALL OVEN REPLACEMENT

With the FIT system, replacing your wall oven has never been easier. You can customize installation to your cabinet cutout\* so the hardest part is choosing which hard-working Maytag® oven fits your life...not your cabinet.



New wall ovens can leave space when installed in old cutouts



Adjustable inserts raise the height to cabinet level



Finishing trim covers the gap for a sleek, seamless appearance

\*Available on 27" and 30" double and single wall ovens. See product specifications for minimum and maximum installation dimensions.



**fit**  
SYSTEM



# Wall Ovens



### 10-Year Limited Parts Warranty\*

The oven elements are covered by a 10-year limited parts warranty\* to ensure the long-lasting performance Maytag brand is known for.



Visit [maytag.com](http://maytag.com) for warranty details.



### 8-Minute Power Preheat

This oven combines the power of the bake and broil burners, convection element and fan to preheat the oven 40% faster in 30" wall ovens.\*\* This way, your meals can get to the table quicker.



### Industry-Leading Capacities†

With industry-leading capacity† and power, Maytag® wall ovens deliver the space to get it all done and the power to get it done fast. Now you can cook everything from everyday meals to large family feasts with confidence.



### Industry-First FIT System

With the innovative FIT system, replacing your wall oven has never been easier. Adjustable inserts give you the flexibility to customize installation to your cabinet cutout,†† so the hardest part is choosing which hard-working Maytag® oven fits your life...not your cabinet.



### EvenAir™ True Convection with Third Element and Auto Conversion

With convection, you'll be able to roast foods up to 30% faster than a standard oven, while getting uniform browning and outstanding baking performance. Plus, Auto Conversion converts standard time and temperatures to their convection equivalents, making sure your legendary family recipes come out perfect.



**MEW7627A 27"**  
8.6 cu. ft. total capacity  
W/B/S



**MEW9627A 27"**  
8.6 cu. ft. total capacity  
B/S



**MEW7630A 30"**  
10 cu. ft. total capacity  
W/B/S



**MEW9630A 30"**  
10 cu. ft. total capacity  
B/S

MODELS	MEW7627A	MEW9627A	MEW7630A	MEW9630A
10-year limited parts warranty* on oven elements	•	•	•	•
<b>OVEN FEATURES</b>				
Auto Conversion option		<b>Upper</b>		<b>Upper</b>
Automatic oven light	•	•	•	•
Capacity - total (cu. ft.)	8.6	8.6	10.0	10.0
Upper oven (cu. ft.)	4.3	4.3	5.0	5.0
Lower oven (cu. ft.)	4.3	4.3	5.0	5.0
Closed door broiling	•	•	•	•
EvenAir™ true convection with third element		<b>Upper</b>		<b>Upper</b>
FIT system	•	•	•	•
Heavy-duty oven racks (upper/lower)	2/2	2/2	2/2	2/2
Heavy-duty third roll-out rack (upper)		<b>1 Upper</b>		<b>1 Upper</b>
Hidden bake element	•	•	•	•
Optional porcelain-enamel broiler pan	Part no. 4396923RW	Part no. 4396923RW	Part no. 4396923RW	Part no. 4396923RW
Oven rack positions (upper/lower)	6/6	6/6	6/6	6/6
Panoramic view oven window	•	•	•	•
Power Preheat	•	•	•	•
Precision Cooking™ system with Precise Preheat, Precise Bake and Precise Broil	•	•	•	•
Sabbath Mode	•	•	•	•
Self-cleaning oven with adjustable levels	Upper/Lower	Upper/Lower	Upper/Lower	Upper/Lower
Size	27"	27"	30"	30"
Variable Broil	•	•	•	•
<b>CONTROL FEATURES</b>				
Control lockout	•	•	•	•
Cook & Hold setting (upper oven)	•	•	•	•
Keep Warm™ and Delay Bake/Clean settings	•	•	•	•
Display readout	Amber	Amber	Amber	Amber
Electronic clock with timer	•	•	•	•
Favorite setting	•	•	•	•
Reliable electronic touch oven controls	•	<b>with 4.3" LCD screen</b>	•	<b>with 4.3" LCD screen</b>
<b>BETTER BUILT COMPONENT</b>				
2X Life** door hinges	•	•	•	•
Durable metal door handles	•	•	•	•
<b>SPECIFICATIONS</b>				
Cutout dimensions (opening height† x width x depth)	48-7/8" – 52-3/16" x 25-1/2" x 24"	48-7/8" – 52-3/16" x 25-1/2" x 24"	48-7/8" – 52-3/16" x 28-1/2" x 24"	48-7/8" – 52-3/16" x 28-1/2" x 24"
Overall dimensions (height x width x depth including handles)	51-3/16" x 27" x 23-1/4"	51-3/16" x 27" x 23-1/4"	51-3/16" x 30" x 23-1/4"	51-3/16" x 30" x 23-1/4"
Volts (amps) required	240/208 (40)	240/208 (40)	240/208 (40)	240/208 (40)
Color options	W/B/S	B/S	W/B/S	B/S

**Bold type indicates step-up feature**

**COLOR OPTIONS**



**W**  
White



**B**  
Black



**S**  
Stainless Steel

**LIMITED PARTS WARRANTY COVERED MODELS**



Visit [maytag.com](http://maytag.com) for warranty details.

**MEW7627A MEW7630A**  
**MEW9627A MEW9630A**

Feature glossary can be found on page 134.  
Complete product specifications can be found on page 139.  
Accessories can be found on page 152.

\*Visit [maytag.com](http://maytag.com) for warranty details. \*\*Twice the life testing based on average use.  
†With FIT system height ranges for MEW7627A, MEW9627A, MEW7630A & MEW9630A.



**MEW7527A 27"**

4.3 cu. ft. capacity  
W/B/S



**MEW9527A 27"**

4.3 cu. ft. capacity  
B/S



**MEW7530A 30"**

5.0 cu. ft. capacity  
W/B/S



**MEW9530A 30"**

5.0 cu. ft. capacity  
B/S



**MMW9730A 30"**

1.4 cu. ft. capacity microwave  
5.0 cu. ft. capacity oven  
B/S



COMBINATION WALL OVEN					
MODELS	MEW7527A	MEW9527A	MEW7530A	MEW9530A	MMW9730A
10-year limited parts warranty* on oven elements	•	•	•	•	•
<b>OVEN FEATURES</b>					
Auto Conversion option		•		•	•
Automatic oven light	•	•	•	•	•
Capacity (cu. ft.)	4.3	4.3	5.0	5.0	1.4 (Microwave) / 5.0 (Oven)
Closed door variable broil	•	•	•	•	•
EvenAir™ true convection with third element		•		•	•
FIT system	•	•	•	•	•
Heavy-duty oven racks	2	2	2	2	2 Lower oven
Heavy-duty third roll-out rack		1		1	1
Hidden bake element	•	•	•	•	•
Optional porcelain-enamel broiler pan	Part no. 4396923RW	Part no. 4396923RW	Part no. 4396923RW	Part no. 4396923RW	Part no. 4396923RW
Oven rack positions	6	6	6	6	6 Lower oven
Panoramic view oven window	•	•	•	•	•
Power Preheat		•		•	•
Precision Cooking™ system with Precise Preheat, Precise Bake and Precise Broil	•	•	•	•	•
Sabbath Mode	•	•	•	•	•
Self-cleaning oven with adjustable levels	•	•	•	•	Lower oven
Size	27"	27"	30"	30"	30"
<b>CONTROL FEATURES</b>					
Control lockout	•	•	•	•	•
Cook & Hold setting	•		•		
Keep Warm™ and Delay Bake/Clean settings	•	•	•	•	•
Display readout	Amber	Amber	Amber	Amber	Amber
Electronic clock with timer	•	•	•	•	•
Favorite setting	•	•	•	•	•
Reliable electronic touch oven controls	•	<b>with 4.3" LCD screen</b>	•	<b>with 4.3" LCD screen</b>	with 4.3" LCD screen
<b>MICROWAVE FEATURES</b>					
Auto Cook/Auto Reheat/Auto Defrost					•
Drop down door					•
Sensor cooking					•
<b>BETTER BUILT COMPONENTS</b>					
2X Life** door hinges	•	•	•	•	•
Durable metal door handles	•	•	•	•	•
Stainless steel microwave interior					•
<b>SPECIFICATIONS</b>					
Cutout dimensions (opening height† x width x depth)	26-15/16" – 29-7/16" x 25-1/2" x 24"	26-15/16" – 29-7/16" x 25-1/2" x 24"	26-15/16" – 29-7/16" x 25-1/2" x 24"	26-15/16" – 29-7/16" x 25-1/2" x 24"	41" – 41-1/2" x 28-1/2" x 24"
Overall dimensions (height x width x depth including handles)	28-3/4" x 27" x 23-1/4"	28-3/4" x 27" x 23-1/4"	28-3/4" x 30" x 23-1/4"	28-3/4" x 30" x 23-1/4"	42-9/16" x 30" x 23-1/4"
Volts (amps) required	240/208 (20)	240/208 (30)	240/208 (20)	240/208 (20)	240/208 (40)
Color options	W/B/S	B/S	W/B/S	B/S	B/S

**Bold type indicates step-up feature**

**COLOR OPTIONS**



**W**  
White



**B**  
Black



**S**  
Stainless Steel

**LIMITED PARTS WARRANTY COVERED MODELS**



Visit [maytag.com](http://maytag.com) for warranty details.

**MEW7527A** **MEW9530A**  
**MEW9527A** **MMW9730A**  
**MEW7530A**

Feature glossary can be found on page 134.  
 Complete product specifications can be found on page 139.  
 Accessories can be found on page 152.

\*Visit [maytag.com](http://maytag.com) for warranty details. \*\*Twice the life testing based on average use.  
 †With FIT system height ranges for MEW7527A, MEW9527A, MEW7530A, MEW9530A & MMW9730A.



**CWE5100AC 24"**

5.2 cu. ft. total capacity

B



**CWE5800AC 24"**

5.2 cu. ft. total capacity

E/B/S



**CWE4100AC 24"**

2.8 cu. ft. capacity

E/B



**CWE4800AC 24"**

2.8 cu. ft. capacity

E/B/S



**CWG3100AA 24"**

4.0 cu. ft. total capacity

E/B/S



**CWG3600AA 24"**

4.9 cu. ft. total capacity

B/S

MODELS	ELECTRIC DOUBLE WALL OVENS		ELECTRIC SINGLE WALL OVENS		GAS SINGLE WITH BROILER WALL OVENS	
	CWE5100AC	CWE5800AC	CWE4100AC	CWE4800AC	CWG3100AA	CWG3600AA
<b>OVEN FEATURES</b>						
Broiler compartment					<b>Standard</b>	<b>Extra-large</b>
Broiler compartment window with light						•
Capacity - total (cu. ft.)	5.2	5.2	2.8	2.8	4.0	<b>4.9</b>
Upper oven (cu. ft.)	2.8	2.8			2.7	2.7
Lower oven (cu. ft.)	2.4	2.4			1.3 Broiler	<b>2.2 Broiler</b>
Dual-control broiler elements	•	•	•	•		
Optional porcelain-enamel broiler pan	Part no. 4396923RW	Part no. 4396923RW	Part no. 4396923RW	Part no. 4396923RW	Included	Included
Oven light	•	•	•	•	•	•
Oven rack positions (upper/lower)	4/3	4/3	4	4	4/2	<b>4/3</b>
Precision Cooking™ system with Precise Preheat, Precise Bake and Precise Broil	•	•	•	•	•	•
Self-cleaning oven with adjustable levels		<b>Upper</b>			•	
Size	24"	24"	24"	24"	24"	24"
Standard oven racks (upper/lower)	2/1	2/1	2	2	2/1	2/1
Standard oven window	•	•	•	•	•	•
<b>CONTROL FEATURES</b>						
Delay Start oven control		•			•	•
Display readout	Green	Green	Green	Green	Green	Green
Electronic clock with timer	•	•	•	•	•	•
Reliable electronic touch oven controls	•	•	•	•	•	•
<b>EXTERIOR FEATURES</b>						
Frameless glass-front oven door	•	•	•	•	•	•
Monochromatic oven handles	•	•	•	•	•	Monochromatic
<b>SPECIFICATIONS</b>						
Cutout dimensions (opening height x width x depth)	45-3/8" x 22-3/8" x 24"	45-3/8" x 22-3/8" x 24"	28-11/16" x 22-3/8" x 24"	28-11/16" x 22-3/8" x 24"	38" x 22-3/8" x 24"	45-3/8" x 22-3/8" x 24"
Overall dimensions (height x width x depth including handles)	46-5/16" x 23-7/8" x 27-1/4"	46-5/16" x 23-7/8" x 27-1/4"	29-5/8" x 23-7/8" x 27-1/4"	29-5/8" x 23-7/8" x 27-1/4"	39-1/4" x 23-7/8" x 27-1/2"	46-5/16" x 23-7/8" x 27-1/2"
Volts (amps) required	240/208 (40)	240/208 (40)	240/208 (20)	240/208 (20)	120 (15)	120 (15)
Color options	B	E/B/S	E/B	E/B/S	E/B/S	B/S

**Bold type indicates step-up feature**

**COLOR OPTIONS**



**E**  
White



**B**  
Black



**S**  
Stainless Steel

Feature glossary can be found on page 134.  
Complete product specifications can be found on page 140.  
Accessories can be found on page 152.



# Cooktops



### Sleek Styling

The frameless design and smooth, seamless surface on Maytag brand built-in cooktops provide a streamlined, premium look to any kitchen. Pair a cooktop with a redesigned wall oven for a powerful cooking package that will update any kitchen.



### Smoothtop Glass-Ceramic Surface

This smooth, shatter-resistant cooktop can be easily cleaned. It also resists scratching, chipping and cracking, which keeps it looking better, longer.



### Stainless Steel Surface with DuraClean™ Continuous Die-Cast Metal Recessed Grates

Recessed grates bring a sleek, commercial look to the cooktop and allow for pots and pans to smoothly slide around for fewer spills and easier transition.



### Power Cook Burner

At 15,000-BTUs, this burner provides the power necessary for faster boiling and better searing. It's ideal for large jobs like stir-frying and canning.



### Flex-Choice™ Simmer Burner

Cook a variety of sauces and soups on this burner. With adjustable levels of heat, from 5,000-BTUs down to 1,000-BTUs, it provides a full-power simmer burner and warm setting in one.

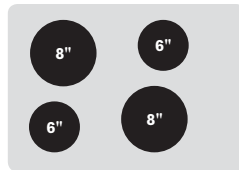

**MEC4430W 30"**

W/B

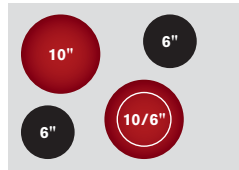

**NEW MEC7430B 30"**

W/B/S

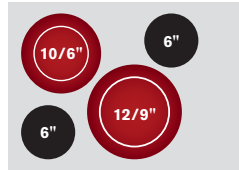
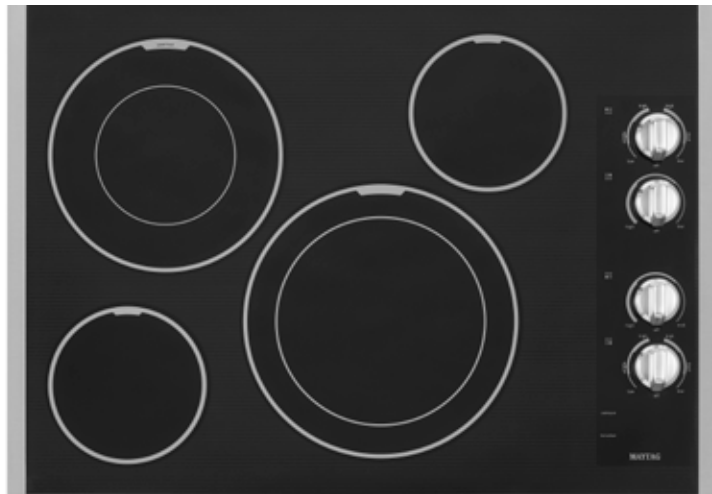

**NEW MEC9530B 30"**

B/S

MODELS	NEW MODELS		
	MEC4430W	MEC7430B	MEC9530B
10-year limited parts warranty* on cooktop elements		•	•
Frameless design	•	•	•
No-drip chrome bowls	•		
Porcelain-enamel surface	•		
Size	30"	30"	30"
Smoothtop glass-ceramic surface		•	•
<b>POWER CENTER FEATURES</b>			
10", 3,200-watt Speed Heat™ radiant element		<b>LR</b>	
10"/6", 3,000/1,400-watt Dual-Choice™ radiant element		<b>RF</b>	LR
12"/9", 3,000/1,950-watt Dual-Choice™ radiant element			<b>RF</b>
<b>COOKTOP FEATURES</b>			
6", 1,200-watt radiant element		<b>LF, RR</b>	LF, RR
6", 1,500-watt coil element	LF, RR		
8", 2,350-watt coil element	LR, RF		
<b>CONTROL FEATURES</b>			
Dishwasher safe removable control knobs	•	•	•
Element-in-Use/Hot surface indicator lights	•	•	•
<b>BETTER BUILT COMPONENT</b>			
Shatter-resistant cooktop		•	•
<b>SPECIFICATIONS</b>			
Cutout dimensions (opening width x depth)	28-5/16" x 19-13/16"	29-1/2" x 20-1/2"	29-1/2" x 20-1/2"
Overall dimensions (height x width x depth)	3-1/4" x 30" x 21"	3-3/4" x 31" x 21-3/4"	3-3/4" x 31" x 21-3/4"
Volts (amps) required	240/208 (40)	240/208 (40)	240/208 (40)
Color options	W/B	W/B/S	B/S

**Bold type indicates step-up feature**

**COLOR OPTIONS**



**W**  
White



**B**  
Black



**S**  
Stainless Steel

**LIMITED PARTS WARRANTY COVERED MODELS**



**MEC7430B**  
**MEC9530B**

Visit [maytag.com](http://maytag.com) for warranty details.

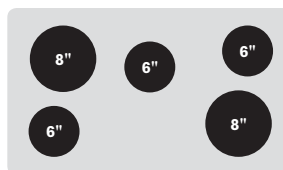

**MEC4536W 36"**

W/B/C

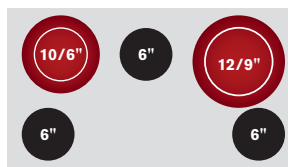

**NEW MEC9536B 36"**

B/S

COLOR OPTIONS



**W**  
White



**B**  
Black



**C**  
Chrome



**S**  
Stainless Steel

LIMITED PARTS WARRANTY COVERED MODEL



Visit [maytag.com](http://maytag.com) for warranty details.

**MEC9536B**



MODELS	MEC4536W	NEW MODEL MEC9536B
10-year limited parts warranty* on cooktop elements		•
Frameless design	•	•
No-drip chrome bowls	•	
Porcelain-enamel surface**	•	
Size	36"	36"
Smoothtop glass-ceramic surface		•
<b>POWER CENTER FEATURES</b>		
10"/6", 3,000/1,400-watt Dual-Choice™ radiant element		<b>LR</b>
12"/9", 3,000/1,950-watt Dual-Choice™ radiant element		<b>RR</b>
<b>COOKTOP FEATURES</b>		
6", 1,200-watt coil element	Center	
6", 1,200-watt radiant element		LF, RF, Center
6", 1,500-watt coil element	LF, RR	
8", 2,350-watt coil element	LR, RF	
<b>CONTROL FEATURES</b>		
Dishwasher safe removable control knobs	•	•
Element-in-Use/Hot surface indicator lights	•	•
<b>BETTER BUILT COMPONENT</b>		
Shatter-resistant cooktop		•
<b>SPECIFICATIONS</b>		
Cutout dimensions (opening width x depth)	34-7/8" x 19-13/16"	35-1/2" x 20-1/2"
Overall dimensions (height x width x depth)	3-1/4" x 36" x 21"	3-3/4" x 36-7/16" x 21-3/4"
Volts (amps) required	240/208 (40)	240/208 (40)
Color options	W/B/C	B/S

**Bold type indicates step-up feature**

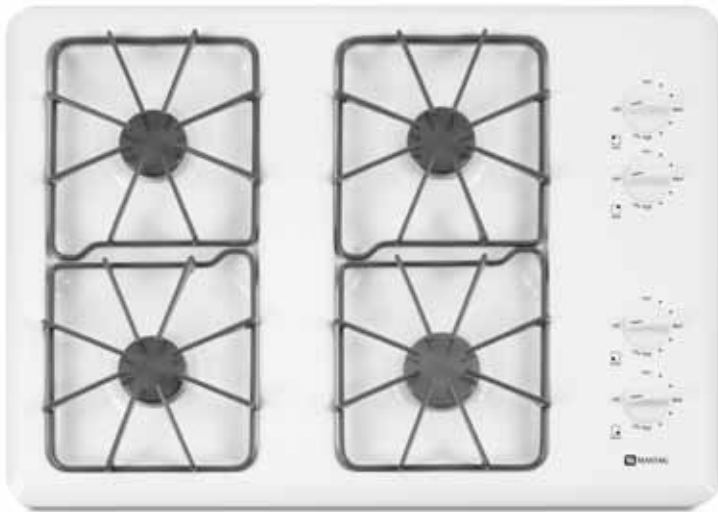

**MGC4430BD 30"**

W/B

9,200 BTU	9,200 BTU
9,200 BTU	12,500 BTU



**MGC7430W 30"**

W/B/S

5,000 BTU	9,200 BTU
12,500 BTU	15,000 BTU



**COLOR OPTIONS**

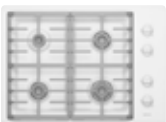

**W**  
White



**B**  
Black



**S**  
Stainless Steel

MODELS	MGC4430BD	MGC7430W
Dishwasher-safe DuraClean™ burner grates	Enamel steel	<b>Continuous die-cast</b>
Dishwasher-safe DuraClean™ lift-off burner caps	•	•
Frameless design	•	•*
Porcelain-enamel surface	•	•
Size	30"	30"
<b>POWER CENTER FEATURES</b>		
12,500-BTU Power Cook burner	RF	LF
15,000-BTU Power Cook burner		<b>RF</b>
<b>COOKTOP FEATURES</b>		
5,000-BTU Flex-Choice™ simmer burner		<b>LR</b>
9,200-BTU burner	LF, LR, RR	RR
Sealed surface burners	•	•
<b>CONTROL FEATURE</b>		
Removable control knobs	•	<b>Dishwasher safe</b>
<b>BETTER BUILT COMPONENT</b>		
Die-cast metal burner grates		•
<b>SPECIFICATIONS</b>		
Cutout dimensions (opening width x depth)	28-1/2" x 19-15/16"	28-1/2" x 19-15/16"
Overall dimensions (height x width x depth)	3-13/16" x 29-1/2" x 21-1/2"	3-13/16" x 29-1/2" x 21-1/2"
Volts (amps) required	120 (10)	120 (10)
Color options	W/B	W/B/S

**Bold type indicates step-up feature**



**MGC4436BD 36"**

W/B

12,000 BTU	9,200 BTU	9,200 BTU
9,200 BTU		12,000 BTU



**MGC7536W 36"**

B/S

12,500 BTU	5,000 BTU	8,000 BTU
9,200 BTU		15,000 BTU



COLOR OPTIONS



**W**  
White



**B**  
Black



**S**  
Stainless Steel

MODELS	MGC4436BD	MGC7536W
Dishwasher-safe DuraClean™ burner grates	Porcelain enamel	<b>Continuous die-cast</b>
Dishwasher-safe DuraClean™ lift-off burner caps	•	•
Frameless design	•	•
Porcelain-enamel surface	•*	•
Size	36"	36"
<b>POWER CENTER FEATURES</b>		
12,000-BTU Power Cook burner	LR, RF	
12,500-BTU Power Cook burner		<b>LR</b>
15,000-BTU Power Cook burner		<b>RF</b>
<b>COOKTOP FEATURES</b>		
5,000-BTU Flex-Choice™ simmer burner		<b>Center</b>
8,000-BTU burner		<b>RR</b>
9,200-BTU burner	LF, Center, RR	LF
Sealed surface burners	•	•
<b>CONTROL FEATURE</b>		
Removable control knobs		<b>Dishwasher safe</b>
<b>BETTER BUILT COMPONENT</b>		
Die-cast metal burner grates		•
<b>SPECIFICATIONS</b>		
Cutout dimensions (opening width x depth)	34-1/2" x 19-15/16"	34-1/2" x 19-15/16"
Overall dimensions (height x width x depth)	3-13/16" x 36" x 21"	3-13/16" x 36" x 21"
Volts (amps) required	120 (10)	120 (10)
Color options	W/B	B/S

**Bold type indicates step-up feature**

**HOODS**



**UXD8630DY 30"** Also available  
S UXT8636DY 36"  
S

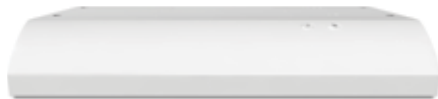

**UXT2030AY 30"** Also available  
W/B UXT2036AY 36"  
W/B



**UXT3030AY 30"** Also available  
W/B UXT3036AY 36"  
W/B



**UXT4030AY 30"** Also available  
W/T/B/S UXT4036AY 36"  
W/B

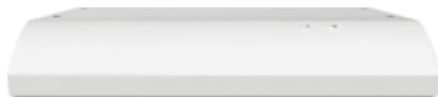

**UXT4130D 30"** Also available  
W/B/S UXT4136D 36"  
W/B



**UXT4230AY 30"** Also available  
W/T/B/S UXT4236AY 36"  
W/B/S



**UXT5230AY 30"** Also available  
W/B/S UXT5236AY 36"  
W/B/S



**UXT5530AA 30"** Also available  
S UXT5536AA 36"  
S



**UXW6530B 30"** Also available  
S UXW6536B 36"  
S



**UXW7230B 30"** Also available  
S UXW7236AY 36"  
S

**COLOR OPTIONS**



**W**  
White



**T**  
Bisque



**B**  
Black



**S**  
Stainless Steel

**HOOD LINERS**



**UXL5430BS 30"**  
S



**UXL6036YS 36"**  
S



**UXL6048YS 48"**  
S

HOODS	UXD8630DY	UXT2030AY	UXT3030AY	UXT4030AY	UXT4130D	UXT4230AY	UXT5230AY	UXT5530AA	UXW6530B	UXW7230B
Also available in 36"	UXD8636DY	UXT2036AY	UXT3036AY	UXT4036AY	UXT4136D	UXT4236AY	UXT5236AY	UXT5536AA	UXW6536B	UXW7236B
Horizontal venting	Exterior		Exterior	Interior	Exterior and interior	Exterior and interior	Exterior and interior	Exterior and interior		
Size	30"	30"	30"	30"	30"	30"	30"	30"	30"	30"
Type	Pop-up downdraft	Top venting only	Top and rear venting	Recirculating only	Convertible	Convertible	Convertible	Convertible	Canopy	Canopy
Vertical venting	Exterior	Exterior	Exterior	Interior	Exterior and interior	Exterior and interior	Exterior and interior	Exterior and interior	Exterior and recirculating	Exterior and recirculating
<b>DUCT TYPE</b>										
3-1/4" x 10" rectangular duct	Included		Included		Included	Included	Included	Included		
6" round duct	Included								Included	Included
7" round duct		Included				Included	W10355451			
Dishwasher-safe grease filters	2	1	1		1	1	1	2 (30") or 3 (36")	Yes	Yes
<b>FEATURES</b>										
Adapter/Vent connector (included)	3-1/4" x 10" Rectangular	7" Round	3-1/4" x 10" Rectangular		3-1/4" x 10" Rectangular	3-1/4" x 10" Rectangular	3-1/4" x 10" Rectangular	3-1/4" x 10" Rectangular	Included	Included
California Title 24 compliant		•	•		•	•	•	•	•	•
Controls	4-speed slider	2-speed, rocker switch	2-speed, rocker switch	2-speed, rocker switch	2-speed, rocker switch	Variable speed, rotary	3-speed, push-button	3-speed, push-button	3-speed, push-button	3-speed, push-button
Damper	•						•	•	•	•
Fan	Dual centrifugal	Axial	Axial	Axial	Axial	Axial	Axial	Centrifugal	Centrifugal	Centrifugal
Lighting		75-watt On/Off incandescent	75-watt On/Off incandescent	75-watt On/Off incandescent	75-watt On/Off incandescent	75-watt High/Low/Off incandescent	50-watt On/Off halogen (bulbs included)	50-watt On/Off halogen (bulbs included)	75-watt On/Off incandescent	75-watt On/Off incandescent
Maximum exhaust (CFM)*	600	190	190		190	225	350	400	400	400
Recirculation kit/charcoal filter				Included	Optional	Optional	Optional	Included	Included	Included
Sones*	up to 7.9	up to 4.5	up to 5.3		up to 5.3	up to 7	up to 9	up to 8.2	7.2	6.9
<b>ACCESSORIES</b>										
7" Damper plate						W10388168	W10388168			
7" Round damper						W10355451	W10355451			
Power cord		W10355452	W10355452	W10355452	W10355452	W10355452	W10355452			
Recirculation/Charcoal filter kit				W10355450	W10355450	W10355450	30" model - W10369358 36" model - W10386873	W10272068	W10349327/ W10412939	W10349327/ W10412939
<b>SPECIFICATIONS</b>										
30" Dimensions (height x width x depth)	29" x 30" x 12-1/8"	5" x 29-15/16" x 18-5/8"	5" x 29-15/16" x 18-5/8"	5" x 29-15/16" x 18-5/8"	5" x 29-15/16" x 18-5/8"	5" x 29-15/16" x 18-5/8"	5" x 29-15/16" x 18-5/8"	9" x 29-7/8" x 19-3/4"	32-1/8" x 30" x 20"	42-1/16" x 30" x 20"
36" Dimensions (height x width x depth)	29" x 36" x 12-1/8"	5" x 35-15/16" x 18-5/8"	5" x 35-15/16" x 18-5/8"	5" x 35-15/16" x 18-5/8"	5" x 35-15/16" x 18-5/8"	5" x 35-15/16" x 18-5/8"	5" x 35-15/16" x 18-5/8"	9" x 35-7/8" x 19-3/4"	27-1/8" - 45-1/2" x 36" x 20"	28-3/8" - 38" x 36" x 20"
30" Color options	S	W/B	W/B	W/T/B/S	W/B	W/T/B/S	W/B/S	S	S	S
36" Color options	S	W/B	W/B	W/B	W/B	W/B/S	W/B/S	S	S	S
<b>HOOD LINERS</b>										
Duct type		UXL5430BS				UXL6036YS			UXL6048YS	
Size		6" round				10" round			10" round	
Type		Convertible				Vented			Vented	
Vertical venting		•				•			•	
<b>FEATURES</b>										
Auto-on heat sensor						•			•	
Controls		3-speed, push-button				3-speed slider			3-speed slider	
Dishwasher-safe grease filters		2				3			4	
Lighting (bulbs included)		(2) 50-watt On/Off halogen				(4) 50-watt High/Low halogen			(4) 50-watt High/Low halogen	
<b>ACCESSORIES</b>										
Blower motor systems		Blower included (400 CFM)				Internal 600 CFM - UXB0600DYS Internal 1200 CFM - UXB1200DYS In-line 600 CFM - UXI0600DYS In-line 1200 CFM - UXI1200DYS			Internal 600 CFM - UXB0600DYS Internal 1200 CFM - UXB1200DYS In-line 600 CFM - UXI0600DYS In-line 1200 CFM - UXI1200DYS	
Face panel (36" x 18")		W10490310				N/A			N/A	
Face panel rear extension (30" x 18")		W10490327				N/A			N/A	
Recirculation/Charcoal filter kit		W10490330				N/A			N/A	
<b>SPECIFICATIONS</b>										
Dimensions (height x width x depth)		13-5/8" x 30" x 11-7/8"				11-1/2" x 35-7/8" x 22"			11-1/2" x 47-7/8" x 22"	
Color options		S				S			S	

\*View Use & Care Guide for more information.

**#****10-Year Limited Parts Warranty\***

Some Maytag® cooktops, microwaves, ovens and ranges include select components backed by a 10-year limited parts warranty\* for long-lasting performance.

**2X Life Tested\*\***

Select durable Maytag brand parts are tested to twice the average life expectancy to help ensure years of dependability.

**A****Add 1 Minute Option**

Allows you to add one minute instantly to any microwave cycle already in progress.

**AquaLift® Self-Cleaning Technology**

The odor-free, low temperature self-cleaning technology that takes less than an hour. An innovative coating on the interior activates with water and heat to release tough, baked-on soils from underneath so food and debris easily wipe away.

**Auto Conversion Option**

On freestanding ranges, converts temperature when using EvenAir™ true convection cooking, helping to eliminate guesswork.

**B****Better Built Components**

Select Maytag® cooking products feature certain components that are Better Built, providing the enhanced performance Maytag brand is known for.

**Bridge Element**

This element connects two cooking elements to help accommodate longer cookware for more cooking flexibility.

**C****Charcoal Filter**

High airflow passes through this filter to quickly and efficiently help neutralize odor and remove steam from the kitchen.

**Closed Door Broiling**

Allows you to cook food without overheating the kitchen or letting food odors escape.

**Convect Conversion Option**

See Auto Conversion.

**Cook & Hold Setting**

Automatically reduces oven temperature after cooking time is up, keeping dishes warm for up to one hour.

**D****Delay Bake Setting**

Lets you program the oven to begin cooking at a preset time so dinner is conveniently ready when you need it to be.

**Delay Clean Setting**

Lets you program the oven to begin the self-clean cycle at a preset time when it's most convenient for you and your schedule.

**Dual-Choice™ Element**

Allows you to match the element size to the pan size for more even heating and extended cooktop flexibility.

**DuraClean™ Heavy-Duty Continuous Die-Cast Metal Burner Grates**

Makes using and moving large pots and pans easier. The durable porcelain-coated die-cast metal surface takes a scrubbing and resists scratching to stay looking its best.

**E****EvenAir™ Convection**

A fan evenly circulates air, providing a consistent oven temperature for uniform browning, even baking and faster roasting.

**EvenAir™ True Convection**

Uses a high-wattage element and fan to roast up to 30% faster than a standard oven and keep oven temperatures consistent to provide uniform browning and even baking.

**F****FIT System**

Adjustable inserts give the flexibility to customize wall oven installation to the cabinet cutout,<sup>†</sup> so the hardest part is choosing which hard-working Maytag® oven fits your life...not your cabinet.

**Flex-Choice™ Simmer Burner**

Burner features adjustable levels of heat, from 5,000 BTUs down to 1,000 BTUs to provide a full-power simmer burner and warm setting in one.

**H****Heavy-Duty Hinges**

As part of Maytag brand's Better Built components, these hinges provide long-lasting stability for the oven door.

**Heavy-Duty Oven Racks**

These racks are 30% stronger than previous racks to support two 16-lb turkeys. Select models have a roll-out rack featuring full extension glides on ball bearings that slide out smoothly for easy access to large meals.

**Hidden Bake Element/Burner**

Creates a smooth oven floor, so spills are easy to clean without maneuvering around heating coils.

**Hot Surface Indicator Light**

Illuminates when the cooktop surface is hot to the touch, even after the heating element has been turned off.

**I****Induction Cooking**

This advanced cooking technology uses electromagnetic energy to quickly generate heat directly in the cookware, leaving the surrounding cooktop cool to the touch so food won't bake on.

**K****Keep Warm™ Setting**

Maintains food temperature so everything is hot and ready to serve at once.

**M****Max Capacity Racks**

This lower oven rack is recessed to provide maximum cooking capacity, making it perfect for large, items and holiday meals.

**P****Power Center Cooktop**

Various combinations of electric elements, induction elements and gas burners deliver high-performance options for more cooking versatility than ever before.

**Power Cook Element/Burner**

These high-heat elements and burners provide the power necessary for faster boiling and better searing. They're ideal for completing large cooking jobs, like stir-frying and canning.

**Power Preheat**

Preheats the oven faster than conventional Maytag® ovens to help prepare meals quicker. Gas models use Power Vents on the oven floors to improve air circulation for even quicker preheating.

**Precise Bake**

Heat is evenly distributed throughout the oven, consistently cooking items for flavorful results.

**Precise Broil**

Provides accurate broiling results and optimal browning every time.

**Precise Preheat**

Preheats the oven based on the actual temperature you select—not a preset time—for accuracy and better results.

\*Visit maytag.com for warranty details. \*\*Twice life testing based on accelerated 20-year life testing, normal cycle, average use.

†Available on 27" and 30" double and single wall ovens. See product specifications for minimum and maximum installation dimensions.

Fits cabinet cutouts from 26-15/16" to 29-7/16" for 27" and 30" single wall ovens. Fits cabinet cutouts from 48-7/8" to 52-3/16" for 27" and 30" double ovens.



**Precision Cooking™ System**

This cooking system combines Precise Preheat, Precise Bake and Precise Broil to provide dependable, even cooking throughout the oven for exceptional results and optimal performance.

**Precision Warming™ Center**

This dedicated fifth cooktop element keeps cooked food warm and frees up other elements for additional meal preparation.

**R****Reliable Electronic Touch Controls**

These easy-to-use touchpad electronic controls offer precise temperature adjustment.

**S****Sabbath Mode**

Overrides the oven's automatic shut-off function, keeping it active and making it possible to use the oven on the Sabbath without turning it on.

**Sealed Surface Burners with Electronic Ignition**

These burners are sealed for even heating and easy cleanup. Electronic ignition lights the burner without the hassle of a pilot.

**Self-Cleaning with Adjustable Levels**

Automatically cleans the oven according to a pre-programmed cycle that allows you to match the cleaning level to the amount of food buildup in the oven—light, medium or heavy.

**Sensor Cooking Options**

Cooks a wide range of foods by monitoring and automatically adjusting cooking time as needed.

**Smoothtop Glass-Ceramic Cooking Surface**

This easy-to-clean cooktop surface can be scrubbed without scratching the surface, keeping it looking great longer.

**Soften/Melt Option**

Gently and evenly soften or melt delicate food like cream cheese or chocolate without cooking or burning.

**Speed Heat™ Element/Burner**

These 3,200-watt electric elements, 3,700-watt induction elements and 17,000-BTU burners are perfect for handling large cooking jobs such as searing steak or quickly boiling water.

**T****Triple-Choice™ Element**

Provides more cooktop options and ensures even heating by allowing you to match the cooking surface to the pan size.

**W****WideGlide™ Tray**

Designed to move throughout the microwave for uniform cooking results—even in cookware as large as a 10" x 15" pan.

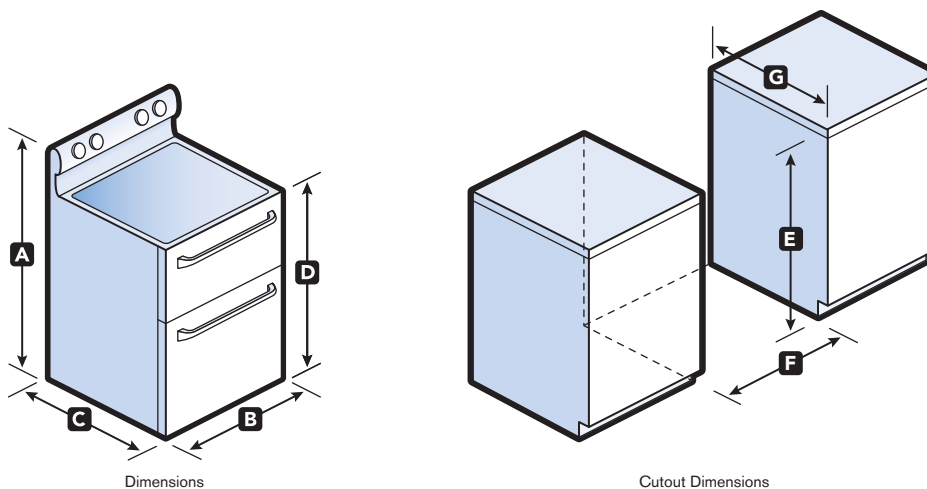

ELECTRIC MODELS	MET8665X	MET8776B	MET8885X	MIT8795B
<b>DIMENSIONS &amp; SPECIFICATIONS</b>				
Height (A)	47-1/8"	47-1/8"	47-1/8"	47-1/8"
Width (B)	29-15/16"	29-15/16"	29-15/16"	29-15/16"
Depth including handles (C)	28-1/2"	28-1/2"	28-1/2"	28-1/2"
Height to cooktop (D)	36"	36"	36"	36"
Total connected load (kW @240V/208V)	13.9/10.5	14/10.5	13.5/10.1	14/10.5
Volts (amps) required	220 (40)	220 (40)	220 (40)	220 (40)
Approximate shipping weight	225 lbs	225 lbs	225 lbs	225 lbs
<b>CUTOUT DIMENSIONS</b>				
Height (E)	36"	36"	36"	36"
Width (F)	30-1/8"	30-1/8"	30-1/8"	30-1/8"
Depth excluding handles (G)	24"	24"	24"	24"
<b>INTERIOR CAVITY OVEN DIMENSIONS</b>				
Upper oven height	9-3/8"	9-3/8"	9-3/8"	9-3/8"
Upper oven width	25"	25"	25"	25"
Upper oven depth	18-1/2"	18-1/2"	18-1/2"	18-1/2"
Lower oven height	16"	16"	16"	16"
Lower oven width	25"	25"	25"	25"
Lower oven depth	18-1/8"	18-1/8"	18-1/8"	18-1/8"

GAS MODELS	MGT8655X	MGT8775X	MGT8885X
<b>DIMENSIONS &amp; SPECIFICATIONS</b>			
Height (A)	47-1/8"	47-1/8"	47-1/8"
Width (B)	29-15/16"	29-15/16"	29-15/16"
Depth including handles (C)	28-1/2"	28-1/2"	28-1/2"
Height to cooktop (D)	36"	36"	36"
Volts (amps) required	110 (15)	110 (15)	110 (15)
Approximate shipping weight	234 lbs	234 lbs	234 lbs
<b>CUTOUT DIMENSIONS</b>			
Height (E)	36"	36"	36"
Width (F)	30-1/8"	30-1/8"	30-1/8"
Depth excluding handles (G)	24"	24"	24"
<b>INTERIOR CAVITY OVEN DIMENSIONS</b>			
Upper oven height	8"	8"	8"
Upper oven width	25"	25"	25"
Upper oven depth	18-1/2"	18-1/2"	18-1/2"
Lower oven height	14-7/8"	14-7/8"	14-7/8"
Lower oven width	25"	25"	25"
Lower oven depth	18-1/8"	18-1/8"	18-1/8"

Dimensions shown are for planning purposes only.  
See Installation Instructions packed with product for complete information.

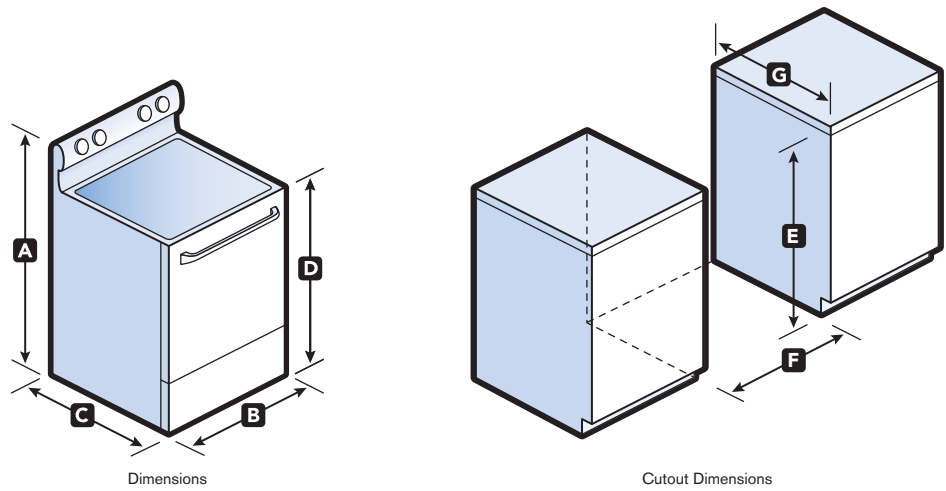

<b>ELECTRIC MODELS</b>	<b>MER7685B</b>	<b>MER8680B</b>	<b>MER8775A</b>	<b>MER8880A</b>	<b>MIR8890A</b>
<b>DIMENSIONS &amp; SPECIFICATIONS</b>					
Height (A)	46-7/8"	46-7/8"	46-7/8"	46-7/8"	46-7/8"
Width (B)	29-7/8"	29-7/8"	29-7/8"	29-7/8"	29-7/8"
Depth including handle (C)	27-1/2"	27-3/4"	27-3/4"	27-3/4"	27-3/4"
Height to cooktop (D)	36"	36"	36"	36"	36"
Total connected load (kW @240V/208V)	12/9	12.2/9.2	12.6/9.5	14.4/10.8	14.6/11
Volts (amps) required	120/15	120/15	120/240 or 120/208 (60)	120/240 or 120/208 (60)	120/240 or 120/208 (60)
Approximate shipping weight	168 lbs	168 lbs	173 lbs	178 lbs	183 lbs
<b>CUTOUT DIMENSIONS</b>					
Height (E)	36"	36"	36"	36"	36"
Width (F)	30"	30"	30"	30"	30"
Depth excluding handle (G)	25-5/16"	25-5/16"	25-5/16"	25-5/16"	25-5/16"
<b>INTERIOR CAVITY OVEN DIMENSIONS</b>					
Height	21-3/8"	21-3/8"	21-3/8"	21-3/8"	21-3/8"
Width	24-3/8"	24-3/8"	24-3/8"	24-3/8"	24-3/8"
Depth	20-3/4"	20-3/4"	20-3/4"	20-3/4"	20-3/4"
<b>GAS MODELS</b>					
	<b>MGR7685A</b>	<b>MGR8670A</b>	<b>MGR8674A</b>	<b>MGR8775A</b>	<b>MGR8880A</b>
<b>DIMENSIONS &amp; SPECIFICATIONS</b>					
Height (A)	46-7/8"	46-7/8"	46-7/8"	46-7/8"	46-7/8"
Width (B)	29-7/8"	29-7/8"	29-7/8"	29-7/8"	29-7/8"
Depth including handle (C)	27-9/16"	27-7/8"	27-7/8"	27-7/8"	27-7/8"
Height to cooktop (D)	36"	36"	36"	36"	36"
Volts (amps) required	120 (15)	120 (15)	120 (15)	120 (15)	120 (15)
Approximate shipping weight	182 lbs	193 lbs	195 lbs	197 lbs	200 lbs
<b>CUTOUT DIMENSIONS</b>					
Height (E)	36"	36"	36"	36"	36"
Width (F)	30"	30"	30"	30"	30"
Depth excluding handle (G)	25-5/16"	25-5/16"	25-7/16"	25-7/16"	25-7/16"
<b>INTERIOR CAVITY OVEN DIMENSIONS</b>					
Height	18-7/8"	20"	20"	20"	20"
Width	24-1/2"	24-3/8"	24-3/8"	24-3/8"	24-3/8"
Depth	18-1/2"	20-3/4"	20-3/4"	20-3/4"	20-3/4"

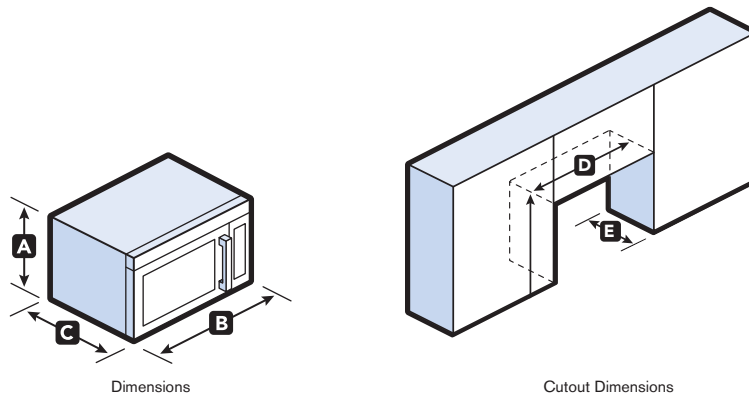

MODELS	UMC5165A	MMV1164W	MMV4203W	MMV4206B	MMV5208W	MMV6180W
<b>DIMENSIONS &amp; SPECIFICATIONS</b>						
Height (A)	13"	17-1/4"	17-1/4"	17-1/4"	17-1/4"	17-1/4"
Width (B)	21-3/4"	29-15/16"	29-15/16"	29-15/16"	29-15/16"	29-15/16"
Depth including handle (C)	17-1/4"	17-3/4"	17-3/4"	17-3/4"	17-3/4"	17-3/4"
Depth excluding handle	17-1/4"	16"	16"	16"	16"	16"
Tray	13-1/2" Diameter	12-1/4" Diameter	12-1/4" Diameter	12-1/4" Diameter	15-3/4" W x 13" D	12-1/4" Diameter
Volts (amps) required	120 (15-20)	120 (15-20)	120 (15-20)	120 (15-20)	120 (15-20)	120 (15-20)
Approximate shipping weight	42 lbs	72 lbs	74 lbs	74 lbs	74 lbs	76 lbs
<b>CUTOUT DIMENSIONS</b>						
Opening width (D)	-	30"	30"	30"	30"	30"
Opening depth (E)	-	12"	12"	12"	12"	12"

Dimensions shown are for planning purposes only.  
See Installation Instructions packed with product for complete information.

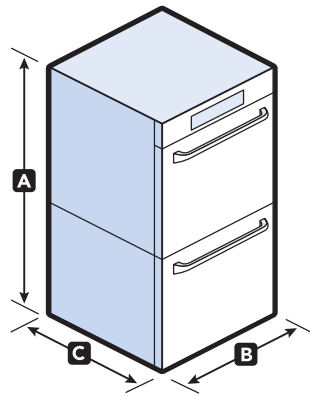

Dimensions

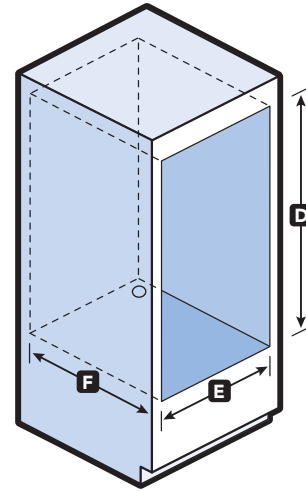

Cutout Dimensions

DOUBLE & COMBINATION MODELS	MEW7627A	MEW9627A	MEW7630A	MEW9630A	MMW9730A
<b>DIMENSIONS &amp; SPECIFICATIONS</b>					
Height (A)	51-3/16"	51-3/16"	51-3/16"	51-3/16"	42-9/16"
Width (B)	27"	27"	30"	30"	30"
Depth including handles (C)	23-1/4"	23-1/4"	23-1/4"	23-1/4"	26-15/16"
Total connected load @ 208 volts*	5.6 kW	5.6 kW	5.6 kW	5.6 kW	5.6 kW
Total connected load @ 240 volts	7.4 kW	7.4 kW	7.4 kW	7.4 kW	7.4 kW
Volts (amps) required	240/208 (40)	240/208 (40)	240/208 (40)	240/208 (40)	240/208 (40)
Approximate shipping weight	245 lbs	245 lbs	266 lbs	266 lbs	227 lbs
<b>CUTOUT DIMENSIONS</b>					
Opening height (D)**	26-15/16" - 29-7/16"	26-15/16" - 29-7/16"	26-15/16" - 29-7/16"	26-15/16" - 29-7/16"	41-5/16"
Opening width (E)	25-1/2"	25-1/2"	28-1/2"	28-1/2"	28-1/2"
Opening depth (F)	24"	24"	24"	24"	24"

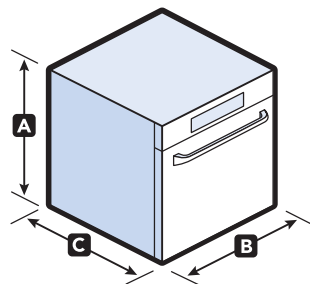

Dimensions

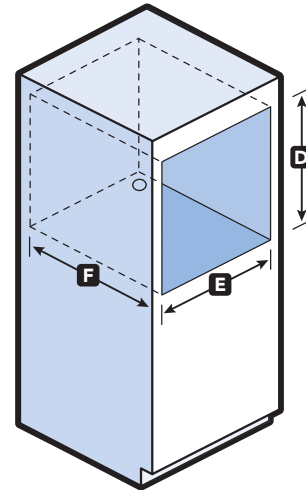

Cutout Dimensions

SINGLE MODELS	MEW7527A	MEW9527A	MEW7530A	MEW9530A
<b>DIMENSIONS &amp; SPECIFICATIONS</b>				
Height (A)	28-3/4"	28-3/4"	28-3/4"	28-3/4"
Width (B)	27"	27"	30"	30"
Depth including handle (C)	23-1/4"	23-1/4"	23-1/4"	23-1/4"
Total connected load @ 208 volts*	2.8 kW	2.8 kW	2.8 kW	2.8 kW
Total connected load @ 240 volts	2.4 kW	2.4 kW	2.4 kW	2.4 kW
Volts (amps) required	240/208 (20)	240/208 (20)	240/208 (30)	240/208 (30)
Approximate shipping weight	138 lbs	138 lbs	149 lbs	149 lbs
<b>CUTOUT DIMENSIONS</b>				
Opening height (D)	26-15/16" - 29-7/16"***	26-15/16" - 29-7/16"***	26-15/16" - 29-7/16"***	26-15/16" - 29-7/16"***
Opening width (E)	25-1/2"	25-1/2"	28-1/2"	28-1/2"
Opening depth (F)	24"	24"	24"	24"

\*Optimized for 240V but can work at 208V also. \*\*With FIT system range height. Dimensions shown are for planning purposes only. See Installation Instructions packed with product for complete information.

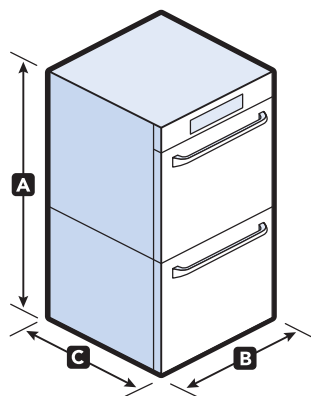

Dimensions

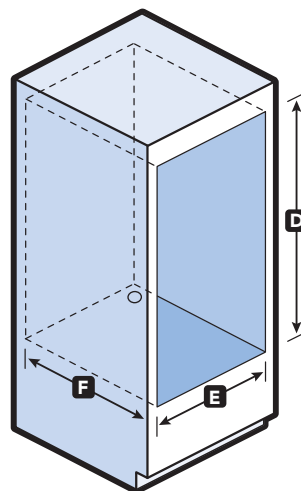

Cutout Dimensions

DOUBLE & SINGLE WITH BROILER MODELS	CWE5100AC	CWE5800AC	CWG3100AA	CWG3600AA
<b>DIMENSIONS &amp; SPECIFICATIONS</b>				
Height (A)	46-5/16"	46-5/16"	39-1/4"	46-5/16"
Width (B)	23-7/8"	23-7/8"	23-7/8"	23-7/8"
Depth including handles (C)	27-1/4"	27-1/4"	27-1/2"	27-1/2"
Total connected load @ 208 volts*	4.9 kW	4.9 kW	-	-
Total connected load @ 240 volts	6.5 kW	6.5 kW	-	-
Volts (amps) required	240/208 (40)	240/208 (40)	120 (15)	120 (15)
Approximate shipping weight	192 lbs	192 lbs	134 lbs	154 lbs
<b>CUTOUT DIMENSIONS</b>				
Opening height (D)	45-3/8"	45-3/8"	38"	45-3/8"
Opening width (E)	22-3/8"	22-3/8"	22-3/8"	22-3/8"
Opening depth (F)	24"	24"	24"	24"

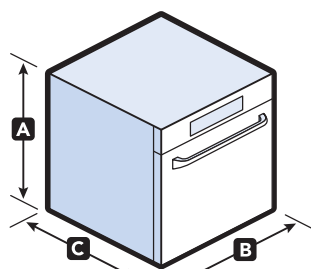

Dimensions

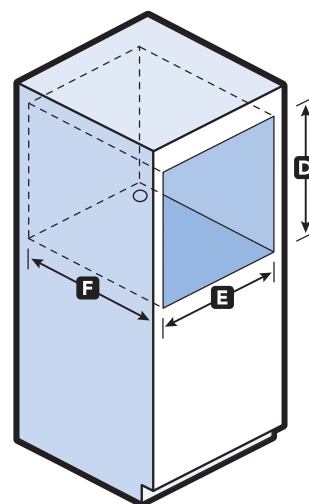

Cutout Dimensions

SINGLE MODELS	CWE4100AC	CWE4800AC
<b>DIMENSIONS &amp; SPECIFICATIONS</b>		
Height (A)	29-5/8"	29-5/8"
Width (B)	23-7/8"	23-7/8"
Depth including handle (C)	27-1/4"	27-1/4"
Total connected load @ 208 volts*	4.4 kW	4.4 kW
Total connected load @ 240 volts	5.8 kW	5.8 kW
Volts (amps) required	240/208 (20)	240/208 (20)
Approximate shipping weight	128 lbs	128 lbs
<b>CUTOUT DIMENSIONS</b>		
Opening height (D)	28-11/16"	28-11/16"
Opening width (E)	22-3/8"	22-3/8"
Opening depth (F)	24"	24"

\*Optimized for 240V but can work at 208V also.  
 Dimensions shown are for planning purposes only.  
 See Installation Instructions packed with product for complete information.

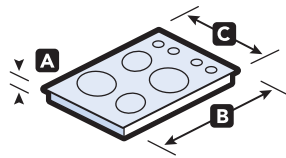

Electric Dimensions

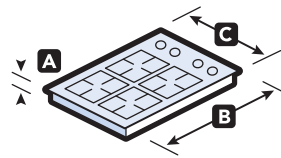

Gas Dimensions

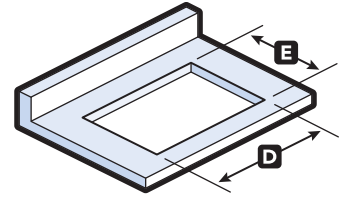

Cutout Dimensions

ELECTRIC MODELS	MEC4430W	MEC4536W	MEC7430B	MEC9530B	MEC9536B
<b>DIMENSIONS &amp; SPECIFICATIONS</b>					
Height (A)	3-1/4"	3-1/4"	3-3/4"	3-3/4"	3-3/4"
Width (B)	30"	36"	31"	31"	36-7/16"
Depth (C)	21"	21"	21-3/4"	21-3/4"	21-3/4"
Volts (amps) required	240/208 (40)	240/208 (40)	240/208 (40)	240/208 (40)	240/208 (40)
Approximate shipping weight	46 lbs	54 lbs	46 lbs	46 lbs	50 lbs
<b>CUTOUT DIMENSIONS</b>					
Opening width (D)	28-5/16"	34-7/8"	29-1/2"	29-1/2"	35-1/2"
Opening depth (E)	19-13/16"	19-13/16"	20-1/2"	20-1/2"	20-1/2"

GAS MODELS	MGC4430BD	MGC7430W	MGC4436BD	MGC7536W
<b>DIMENSIONS &amp; SPECIFICATIONS</b>				
Height (A)	3-13/16"	3-13/16"	3-13/16"	3-13/16"
Width (B)	29-1/2"	29-1/2"	36"	36"
Depth (C)	21-1/2"	21-1/2"	21"	21"
Volts (amps) required	120 (10)	120 (10)	120 (10)	120 (10)
Approximate shipping weight	55 lbs	46 lbs	54 lbs	54 lbs
<b>CUTOUT DIMENSIONS</b>				
Opening width (D)	28-1/2"	28-1/2"	34-1/2"	34-1/2"
Opening depth (E)	19-15/16"	19-15/16"	19-15/16"	19-15/16"

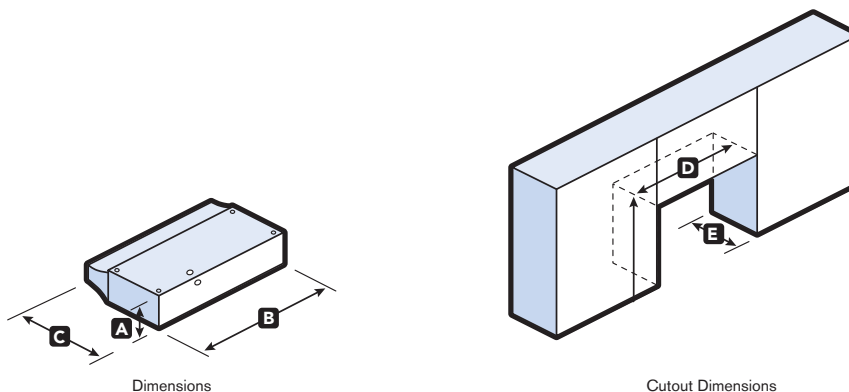

30" HOODS	UXT2030AY	UXT3030AY	UXT4030AY	UXT4130D	UXT4230AY	UXT5230AY	UXT5530AA	UXW6530B	UXW7230B
<b>DIMENSIONS &amp; SPECIFICATIONS</b>									
Height (A)	5"	5"	5"	5"	5"	5"	9"	32-1/8"	42-1/16"
Width (B)	30"	30"	30"	30"	30"	30"	30"	30"	30"
Depth (C)	18-5/8"	18-5/8"	18-5/8"	18-5/8"	18-5/8"	18-5/8"	19-7/10"	20"	20"
Minimum mounting height/rise above cooking surface or countertop	18"	18"	18"	18"	18"	18"	24"	24" (Electric) 27" (Gas)	24" (Electric) 27" (Gas)
Volts (amps) required	120 (15)	120 (15)	120 (15)	120 (15)	120 (15)	120 (15)	120 (15)	120 (15)	120 (15)
Approximate shipping weight	12 lbs	12 lbs	11 lbs	12 lbs	13 lbs	22 lbs	37 lbs	55 lbs	39 lbs
<b>CUTOUT DIMENSIONS</b>									
Width (D)	30"	30"	30"	30"	30"	30"	30"	30"	30"
Depth (E)	11-1/8"	11-1/8"	11-1/8"	11-1/8"	11-1/8"	11-1/8"	19-7/10"	20"	20"

36" UNDER CABINET HOODS	UXT2036AY	UXT3036AY	UXT4036AY	UXT4136AY	UXT4236AY	UXT5236AY	UXT5536AA	UXW6536B	UXW7236B
<b>DIMENSIONS &amp; SPECIFICATIONS</b>									
Height (A)	5"	5"	5"	5"	5"	5"	9"	32-1/8"	28-7/8" x 42-1/16"
Width (B)	36"	36"	36"	36"	36"	36"	36"	36"	36"
Depth (C)	18-5/8"	18-5/8"	18-5/8"	18-5/8"	18-5/8"	18-5/8"	12"	20"	20"
Minimum mounting height/rise above cooking surface or countertop	18"	18"	18"	18"	18"	18"	24"	24" (Electric) 27" (Gas)	24" (Electric) 27" (Gas)
Volts (amps) required	120 (15)	120 (15)	120 (15)	120 (15)	120 (15)	120 (15)	120 (15)	120 (15)	120 (15)
Approximate shipping weight	12 lbs	13 lbs	14 lbs	13 lbs	15 lbs	23 lbs	42 lbs	30 lbs	30 lbs
<b>CUTOUT DIMENSIONS</b>									
Width (D)	36"	36"	36"	36"	36"	36"	36"	36"	36"
Depth (E)	11-1/8"	11-1/8"	11-1/8"	11-1/8"	11-1/8"	11-1/8"	12"	25-3/16"	20"

NOTE: Ducting configuration and length can affect airflow rates. Ratings shown are based on kitchen hoods with correctly installed ducting.

30" AND 36" DOWNDRAFT VENTS	UXD8630DY	UXD8636DY
<b>DIMENSIONS &amp; SPECIFICATIONS</b>		
Height (A)	29"	29"
Width (B)	30"	36"
Depth (C)	12-1/8"	12-1/8"
Rise above countertop	14"	14"
Volts (amps) required	120 (15)	120 (15)
Approximate shipping weight	93 lbs	102 lbs

NOTE: See Use & Care Guide for cutout dimensions.

HOOD LINERS	UXL5430BS	UXL6036YS	UXL6048YS
<b>DIMENSIONS &amp; SPECIFICATIONS</b>			
Height (A)	13-5/8"	11-1/2"	11-1/2"
Width (B)	30"	35-7/8"	47-7/8"
Depth (C)	11-7/8"	22"	22"
Minimum mounting height (above cooking surface)	24"	24"	24"







Products shown (left to right): 8212638RC, W10355049, W10135699, W10355051, W10355010, UKF8001 and 4396096RB

# PEAK PERFORMANCE WITH CONVENIENT ACCESSORIES

MAYTAG APPROVED ACCESSORIES ADD THAT  
SHOWROOM SHINE AND A TUNE UP ANYTIME

Laundry Accessories

**146**

Refrigeration Accessories

**148**

Dishwasher Accessories

**150**

Cooking Accessories

**152**



### Laundry Pedestals

Raise your Maxima XL™ and Maxima X™ laundry pairs for easier loading and unloading. The storage drawer in the 15.5" pedestal holds all of your laundry extras, including full-size detergent bottles. Select pedestals feature chrome accents to add even more style to the laundry room.

### XHP1550V/W\*

15.5" H x 27" W x 26.5" D



**W**  
White



**P**  
Evergreen



**J**  
Oxide



**B**  
Black



**R\***  
Crimson



**L**  
Liquid Silver



**G**  
Granite

### XHPC155X with chrome accents

15.5" H x 27" W x 27.3" D



**W**  
White



**R**  
Crimson



**G**  
Granite

\*Order XHP1550WR for Crimson.



### Laundry 1-2-3™ Adjustable Clothes Rack

Conveniently hang garments from any washer or dryer with this adjustable rack. The rack can be easily attached with scratch-resistant magnets to most full-size washers and dryers and is both collapsible and removable for quick, easy storage.

### XHS1000XX

Load Weight Rating: up to 120 lbs





### affresh® Washer Cleaner

**W10135699**

Effectively removes odor-causing residue from your washer. The affresh® Washer cleaner package includes three tablets.



### Dryer Lint Brush

**8212614**

Helps to extend dryer life and conserve energy for dryers with lint screens on top.



### Multi-Use Cleaning Brush

**4210463RW**

This brush can be used to clean under appliances, as well as on dryers with the lint screen in the front, and helps to extend dryer life and conserve energy.



### 6' Gooseneck Nylon Braided Fill Hose Kit (2-Pk)

**8212638RC (Retail clamshell)**

**8212638RP (Retail polybag)**

6' nylon-braided hose, space-saving 90° elbow with anti-corrosive couplings and pre-installed EPDM washers deliver maximum water flow. Everything needed for installation is included.



### Steam Hose Kit

**W10044609A**

For steam dryers. Includes (1) 5' hook-up hose, (1) 2' hook-up hose and (1) Y-connector. Packed in factory-certified parts polybag.



### Installer's Kit

**4396013RB**

Allows the wall vent to protrude up to 2-1/2" without having to be trimmed. Includes a 4' vent section that attaches to a close elbow, a 4' vent section that attaches to a wall offset and an extension collar.



### Washable Delicates Bag

**W10180464RP**

Protects small items from snags, tangles and tears while machine washing and drying. 15.5" x 16.5".



### Top Load Washer/Dryer Cover

**W10214580RP**

This gray cover fits most top load washers and dryers and helps to protect against environmental damage.



### Washer Drip Tray

**8212526**

Sits under the washer to protect floors from scuffs, spills and overflows. Includes PVC drain fitting and instructions. Will not fit 27" washer/dryer combination units.



**Cyst Water Filter**

**FILTER1 (W10295370A)**  
**FILTER2 (W10413645A)**  
**FILTER4 (UKF8001)**

This built-in PUR® filter reduces contaminants\* while retaining fluoride, giving you chilled, filtered water from your refrigerator for up to six months.



**Push-Button Non-Cyst Filter**

**FILTER3 (4396841)**

Reduces contaminants\* from household water while retaining fluoride, giving you filtered water from your refrigerator for up to six months. Features a simple push-button replacement.



**affresh® Stainless Steel Cleaner (16 fl. oz.)**

**W10355016**

Gently cleans fingerprints, smudges and residue to leave a streak-free, polished shine.



**affresh® Kitchen & Appliance Cleaner (16 fl. oz.)**

**W10355010**

Cuts through everyday spills to leave a streak-free shine. Available for use on appliances, refrigerator interiors, countertops, tubs and sinks.



**Ice Machine Cleaner (16 fl. oz.)**

**4396808**

Ideal for all freestanding ice machines. Cleans and removes build-up.



**FreshFlow™ Produce Preserver Starter Kit**

**P1FB6S1**

Fits in any refrigerator bin. Extends the freshness of produce in your refrigerator.\*\*



**FreshFlow™ Produce Preserver**

**FRESH1 (W10346771A)**

Helps keep produce fresh longer.\*\* Use both packets together. Replace every six months.



**FreshFlow™ Refrigerator Air Filter**

**AIR1 (W10311524)**

Reduces common food odors in the refrigerator. 15X more powerful than baking soda. Replace every six months.



**Refrigerator Deodorizer**

**8171398SRB**

Ideal for the low airflow and high moisture of the refrigerator, this filter absorbs powerful odors like onion, garlic and fish with high-absorbency activated coconut-shell charcoal.

\*The contaminants or other substances removed or reduced by this water filter are not necessarily in all users' water. Use only on municipally treated water or other supply known to be microbiologically safe. \*\*Based on commonly purchased produce.



**Microfiber Cleaning Cloth**

**31625**

All-in-one cloth dusts, polishes and damp cleans nearly any surface while reducing fingerprints without using chemicals. Up to 300 uses. Large size, 16" x 16".



**Freezer Deodorizer**

**4392894SRB**

Ideal for the high airflow and low moisture of the freezer, this filter traps odors before they are frozen in ice cubes (not from water supply) with high-absorbency activated charcoal.



**7' Industrial-Grade Refrigerator Water Hose**

**W10505928RP**

Includes everything needed for easy installation: 7' of braided tubing and fittings to provide water to ice makers and ice and water dispensers.



**Multi-Use Cleaning Brush**

**4210463RW**

Ensure maximum refrigerator efficiency with regular cleaning. Use this handy brush to remove hard-to-reach cobwebs, dust and other airborne particles.



**Egg Container**

**2219124A**

Gain easy access to eggs with this container. Holds 10 eggs.



**Silver Ultra-Finish or Stainless Steel Side Panels**

- Fits Maytag® side-by-side, french door and top-freezer refrigerators
- 1 side panel (fits either side)
- No tools required
- Kit includes everything you need for installation



**Stainless Steel Top Caps**

- Fits Maytag® side-by-side refrigerators built after 2008
- Cannot be used with Contoured Door refrigerators
- One cap adds 3" to refrigerator height
- No tools required
- Kit includes everything you need for installation

SIDE-BY-SIDE COUNTER DEPTH			
CU. FT.	STAINLESS STEEL	DIMENSIONS	
23	4396748	68-5/16" H x 24-1/2" W x 1/32" D	
25	4396749	71-1/8" H x 24-1/2" W x 1/32" D	
SIDE-BY-SIDE FREESTANDING			
CU. FT.	STAINLESS STEEL	SILVER ULTRA-FINISH	DIMENSIONS
25	4396351	8212633	68-3/8" H x 27-11/16" W x 1/32" D
FRENCH DOOR COUNTER DEPTH AND FREESTANDING			
CU. FT.	STAINLESS STEEL	SILVER ULTRA-FINISH	DIMENSIONS
20	W10194323	-	68-5/16" H x 23-11/16" W x 1/32" D
25	W10136753	W10137042	68-3/8" H x 28-11/16" W x 1/32" D

SIDE-BY-SIDE		
CU. FT.	STAINLESS STEEL (1 CAP)	DIMENSIONS
23	W10136975 (Counter Depth)	2-5/8" H x 35-9/16" W x 27-1/16" D
25	W10136975 (Counter Depth)	2-5/8" H x 35-9/16" W x 27-1/16" D
25	W10136976 (Freestanding)	2-5/8" H x 35-9/16" W x 29-15/16" D



**affresh® Dishwasher Cleaner**

**W10282479**

Powers away film and unsightly residue left by some detergents. New formula is Designed for the Environment.\* Environmentally safer\* chemistry dissolves throughout the cycle. Safer to use with dishes.\*\* Contains six pucks.



**affresh® Disposal Cleaner**

**W10509526**

Foaming action works to loosen food and organic material to clean and deodorize. Carton contains four tablets.



**affresh® Stainless Steel Wipes**

**W10355049**

Gently cleans fingerprints, smudges and residue to leave a streak-free, polished shine. Contains 35 use & toss wipes, 7" x 9".



**affresh® Stainless Steel Cleaner (16 fl. oz.)**

**W10355016**

Gently cleans fingerprints, smudges and residue to leave a streak-free, polished shine.



**Dishwasher Swivel Gooseneck Fitting**

**W10273460**

This fitting is 3/4" x 3/8" for easy dishwasher installation. Brass fitting required on dishwashers produced after 2009.



**Universal Industrial-Grade Dishwasher Water Supply Kit (6' Hose)**

**W10278627RP**

Everything you need for easy installation including a 6' EPDM water supply line, two brass compression fittings, a brass elbow and a brass swivel gooseneck fitting.



**6', 3-Prong Dishwasher Power Supply Kit**

**W10278923RP**

This kit includes a 6', 90° power cord, a metal strain relief bracket and wire nuts for close clearance connections.



**12' Drain Hose**

**3385556**

This flexible drain hose for tall tub dishwasher models offers a no-kink design made for hot water.



**Tall Tub Dishwasher Side-Mounting Brackets**

**8212560**

For use with solid surface countertops.

\*Visit [epa.gov/dfe](http://epa.gov/dfe) for more information. \*\*Check manufacturer's suggested cleaning instructions on all dishwasher safe items.





**Dishwasher Floor Mounting Kit**

**4378968**  
Use when undercounter installation is not an option.



**Portable Dishwasher Conversion Kit-Tall Tub**

**W10322576**  
Used to convert a portable dishwasher to fit a built-in application. Includes installation instructions.



**Small Items Bag**

**8519716**  
Securely holds baby items, jar lids, etc. that would normally slip through the rack.



**Small Items Basket**

**3370993RB**  
Holds items that might slip through the rack, such as lids, measuring spoons, baby spoons or corn-on-the-cob holders.



**Dishwasher Rack Repair Kit**

**4396838RC (White)**  
**4396839RC (Blue)**  
**4396840RC (Gray)**  
Kit includes tine tips, vinyl touch-up material and adhesive to repair dishwasher racks. Includes enough for two racks.



**Microfiber Cleaning Cloth**

**31625**  
All-in-one cloth dusts, polishes and damp cleans nearly any surface while reducing fingerprints without using chemicals. Up to 300 uses. Large size, 16" x 16".



**Universal Industrial-Grade 6' Dishwasher Water Supply Kit**

**W10278636RC (Teflon tape)**  
**W10278635RC (No Teflon tape)**  
Includes (1) braided, reinforced hose, (2) 3/8" brass compression fittings, (1) 3/8" brass elbow and (1) 3/4" brass swivel gooseneck fitting.



**Undercounter Mounting Kit**

**W10426979**  
Works with all standard size dishwashers. Can be used with solid surfaces, including granite.



**6' Dishwasher Drain Hose**

**8269144A**  
Flexible drain hose for Tall Tub models.



**affresh® Cooktop Cleaner**

**W10355051**

Cleans glass and ceramic cooktops as well as glass cookware.

**Replacement Scrubbing Pads**

**W10391473**

Scrubbing pads are used to remove light soil or water spots. Safe for all glasses and ceramic surfaces. 20 Pack.



**Granite Cleaner and Polish (16 fl. oz.)**

**W10275756**

This granite cleaner and polish restores brilliance and color. Works on sealed granite and most stone surfaces and leaves a finish to help prevent staining.



**affresh® Kitchen & Appliance Cleaner (16 fl. oz.)**

**W10355010**

Cuts through everyday spills to leave a streak-free shine.



**Gas Grate & Grill Cleaner (4 fl. oz.)**

**31617A**

Cleans porcelain, glass, cast-iron or chrome surfaces. Use this mildly abrasive formula with water and a towel or sponge to effectively remove calcium, mineral deposits, rust, lime scale, soap scum, grease, food stains and spills.



**AquaLift®**  
Self-Cleaning  
Technology

**Oven Cleaning Kit**

**W10423113RP**

**W10510627RB**

**W10432017BU – 6-pack of expanding sponges**

Everything you need to clean both gas and electric ovens featuring AquaLift® self-cleaning technology. Includes one scraper, one scrubbing sponge and one expanding sponge.



**Heavy-Duty BBQ Brushes**

**18001088 (21")**

**W10281603 (16")**

Keep the grill clean and looking like new with these durable brushes.



**4' Gas Range Connector Kit**

**30-48KITRC**

Everything you need to hook up your gas range. Contains 4' connector, three fittings and sealant.



**40-Amp Range Power Cords**

**PT600 (6', 4-wire)**

**PT400 (4', 4-wire)**

**PT220 (4', 3-wire)**

To ensure a correct range installation that meets electrical requirements, a new UL-listed 40-amp power cord should be used.



**Anti-Tip Kit**

**8273888A**

For ranges. Attaches to floor to minimize movement. Installation instructions included. Packed in factory-certified parts polybag.



**Porcelain Broiler Pan & Grid**

**4396923RW**

Drains juice and helps prevent splatter and smoke, making cleaning up easy. 16.5" L x 12.5" W



**13" Brick Baking Stone**

**4378577**

Ideal for pizzas, breads, rolls, cookies and more. Evenly distributes heat for light and crispy brick-oven style cooking.



**Gourmet Griddle**

**4396096RB**

Thaws food quickly without heat and can be used on gas and electric cooktops and ranges to expand cooking surface.



**30" Split Oven Rack\***

**4396927**

Half shelf maximizes oven space. Allows for large items on one side while still using the upper shelf on the opposite side. Packed in factory-certified parts polybag.



**Microwave Crisper Pan**

**W10187336A**

Pan-fry, brown and crisp foods in the microwave. 12.25" Diameter x 1.5" Depth



**Universal Microwave Steamer**

**8205262RB**

Use these dishwasher-safe hard plastic components to steam fish, vegetables or rice. 13.75" H x 8.5" W x 5.25" D



**40-Watt Appliance Bulb**

**8009**

40-watt, 120-volt replacement bulb can be used for ovens, ranges, refrigerators and freezers.

**Countertop Microwave Trim Kit**

Create a built-in look with this trim kit for a countertop microwave. Everything needed for installation is included.

MODELS	UMC5200BAW	UMC5200BAB	UMC5200BAS
<b>TRIM KIT</b>			
27"	UMTK27W	UMTK27B	UMTK27S
30"	UMTK30W	UMTK30B	UMTK30S
Color options	White	Black	Stainless

\*Be sure to check oven model for dimensions to ensure a proper fit.



# GREAT FUTURES START **HERE.**

Providing dependability is a Maytag brand promise that not only applies to our products but to the community, too. That's why we're proud supporters of the Boys & Girls Clubs of America. As an organization that focuses on strengthening the character of young people, we're honored to have developed a dependable partnership that has a positive impact throughout the country. In 2013, Maytag brand will again recognize those Boys & Girls Clubs that are commendable in their performance with a Maytag® Dependable Club award so that they may establish long-lasting improvements and continue to provide the promise of dependability.



**BOYS & GIRLS CLUBS**  
OF AMERICA

# Product support & warranty information

## Parts and Labor Warranty

For one (1) year from the original retail purchase date. See Use and Care Guide for details.

## If You Need Service

First, see the Troubleshooting section in your Use and Care Guide, or call the dealer from whom your appliance was purchased. Or call Maytag Services LLC Customer Assistance at 1-800-344-1274 or 1-800-688-2002 (Canada) to locate an authorized dealer.

## Maytag Customer Experience Center

We want everything about your experience with Maytag brand to exceed your expectations. The Maytag Customer Experience Center is one way we hope to satisfy you. Got a question, comment or concern?

## Please contact us at:

Phone 1-800-344-1274  
Monday-Friday, 8 a.m. – 8 p.m. (ET)



WHAT'S INSIDE MATTERS®

Maytag brand is continuously improving and innovating products, so the specifications in this catalog are subject to change.



WHAT'S INSIDE MATTERS®

WWW.MAYTAG.COM