

Amana[®]

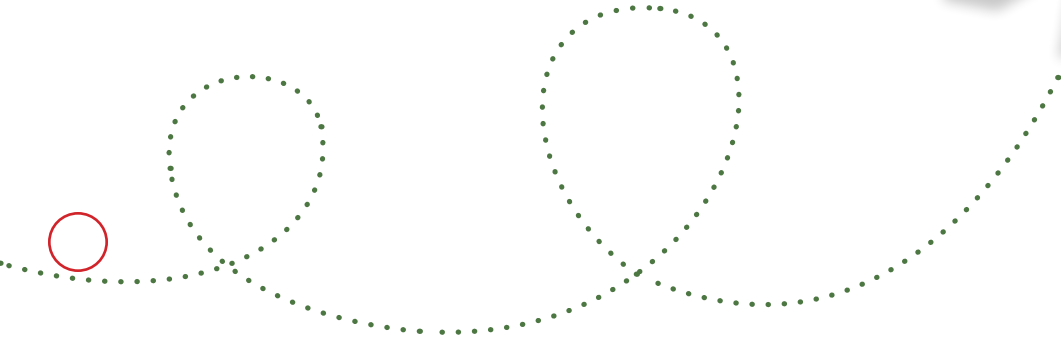

CATALOG 2014



SAVING IS JUST

QUALITY, VALUE AND EVERYDAY SOLUTIONS

Amana brand makes it easy to keep more money in your pocket with uncomplicated appliances for your home. That's why we're the go-to brand for appliances that offer more...for less.





THE START

From “I can afford that?” features to eco-friendly options that save money, we continue to evolve our product line and prove that with Amana brand, **Saving is Just the Start.**

We stand behind our mission and the promise of providing quality appliances that are priced right, simple to use and efficient...for everyone.



LIKE OUR APPLIANCES, WE ARE CONTINUALLY WORKING TO IMPROVE YOUR HOME.

As part of our policy of continuous improvement, Amana brand is always conscious of opportunities to better our product offerings. Our evolving product lineup is designed to better suit your home and budget.

Amana brand strives to continually provide simple solutions and easy-to-use appliances. With our products, you can feel secure knowing they won't compromise on quality, simplicity or efficiency.



TABLE OF CONTENTS

LAUNDRY	6
.....	
DISHWASHERS	20
.....	
COOKING	30
.....	
REFRIGERATORS	50
.....	
FREEZERS	68





Note: Pedestal featured is no longer available.



LAUNDRY

FIT FOR THE ENVIRONMENT AND YOUR BUDGET

Use fewer resources and save more money with laundry pairs that use only what they need to perform at their best. Large capacities and energy-saving features help make laundry day a little more efficient.

Note: Pedestal featured is no longer available.



FRONT-LOAD

PAGE 8



TOP-LOAD

PAGE 12



FRONT-LOAD LAUNDRY



MODELS NFW5800DW, NE/GD5800DW
SHOWN WITH OPTIONAL PEDESTAL XHPC155XW



HIGH EFFICIENCY ALL AROUND

Our HE front-load washer exceeds government standards for **ENERGY STAR®** qualification to help conserve water and energy and help lower your utility bills.

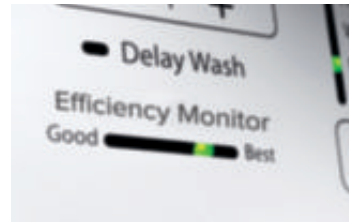

SAVINGS YOU CAN SEE

The **Efficiency Monitor** gives feedback regarding how the cycles and options you choose affect your overall energy savings. Now you can take the mystery out of efficiency.

EFFICIENCY PAYS

OUR HIGH-EFFICIENCY FRONT-LOAD WASHER USES 83% LESS WATER AND 88% LESS ENERGY,* WHILE THE DRYER USES 72% LESS ENERGY, HELPING YOU SAVE \$3,700 DURING THE LIFETIME OF THE PAIR.†**



MULTIPLE CYCLES AND OPTIONS

Wasting water and overdrying clothes are in the past. Choose between **7 wash cycles and 5 dry cycles** that are easy to operate, so you only use the water and energy you need to fit the load.



CUT DOWN ON DRYING TIMES

At 1,200 RPM this washer's **spin speed** saves energy by removing more water in the washer, so clothes spend less time in the dryer.

Note: Not all features included on all models.

*Compared to pre-2004 traditional top-load washers. **Compared to pre-2004 traditional top-load dryers. †Compared to pre-2004 traditional top-load pairs, average use, normal cycle, 11-year washer life and 12-year dryer life, combined washer and dryer water and energy savings, electric only.

MODEL LINEUP

FRONT-LOAD WASHER



4.2 CU. FT.
NFW5800D W



Shown with optional pedestal XHPC155XW

FRONT-LOAD DRYER



7.4 CU. FT.
NE/GD5800D W



Shown with optional pedestal XHPC155XW

PEDESTAL STORAGE DRAWER



XHPC155X W



For every Amana® major appliance sold, a tree will be planted to help rebuild global deforested areas.*

*During 2014, for every major appliance it sells in the U.S., Amana® will donate \$0.10 (the cost of each tree planted). Total donation is expected to plant over 2 million trees.

SPECIFICATIONS

HE FRONT-LOAD WASHER	NFW5800D
Matching Dryer	NE/GD5800D
Matching Pedestal Drawer	XHPC155X
Capacity (cu. ft.)	4.2
ENERGY STAR® Qualified	Yes
HE Wash System	Yes
High Efficiency	Yes
Spin Speed (RPM)	1200
Number of Cycles	7
Clean Washer w/ affresh® Washer Cleaner	Yes
Cold	Yes
Delicates	Yes
Drain & Spin	Yes
Heavy Duty	Yes
Normal	Yes
Quick	Yes
Extra Rinse Option	Yes
Delay Wash	Yes
Efficiency Monitor	Yes
Control Lock	Yes
Automatic Temperature Control	Yes
Water Temperatures	4
Dispensers	Detergent, Bleach and Softener
Stainless Steel Wash Basket	Yes
Colors	W

HE FRONT-LOAD DRYER	NE/GD5800D
Matching Washer	NFW5800D
Matching Pedestal Drawer	XHPC155X
Capacity (cu. ft.)	7.4
Efficiency Monitor	Yes
High Efficiency	Yes
Number of Cycles	5
Delicates	Yes
Heavy Duty	Yes
Normal	Yes
Quick Dry	Yes
Time Dry	Yes
Dryness Levels	3
Temperature Options	4
Control Lockout	Yes
Reversible-Swing Door	Yes
Optional LP Conversion Kit (Gas Models Only)	Yes
Colors	W

COLOR

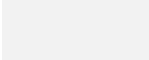
	W White Only
---	------------------------

DIMENSIONS

MODEL	A OVERALL HEIGHT	B OVERALL WIDTH	C OVERALL DEPTH	D DEPTH W/ DOOR OPEN
NFW5800D	39 3/4"	27"	33 1/8"	52 3/4"
NE/GD5800D	39"	27"	31"	51"
XHPC155X	15 1/2"	27"	32 3/4"	-

FRONT-LOAD WASHER/DRYER

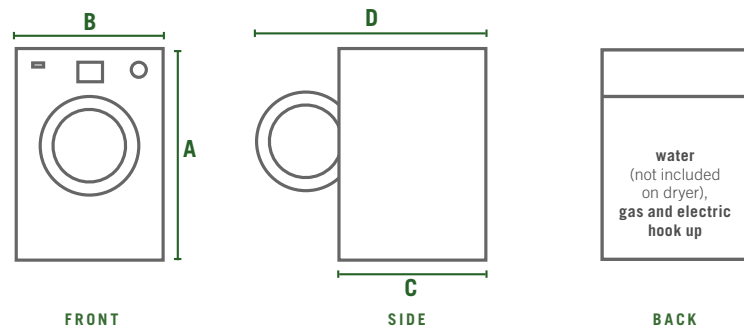

PEDESTAL STORAGE DRAWER

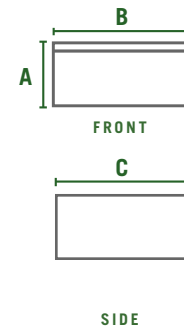

DIMENSIONS ARE SHOWN FOR PLANNING PURPOSES ONLY.

For complete information, see Installation Instructions packed with product.

TOP-LOAD LAUNDRY





HIGH EFFICIENCY ALL AROUND

Our HE top-load washer exceeds government standards for **ENERGY STAR**[®] qualification and meets CEE Tier 3^{*} standards, helping you conserve resources and lower utility bills.



WASH AND DRY MORE AT ONCE

Our **largest-capacity** top-load laundry pair fits more in every load. Now you can conserve resources and cut down on the time and energy spent doing laundry.

TOP SAVINGS WITH TOP LOAD

THIS HIGH-EFFICIENCY PAIR USES UP TO 83% LESS WATER AND 88% LESS ENERGY

IN THE WASHER AND REDUCES ENERGY CONSUMPTION BY 72% IN THE DRYER,[†] HELPING**

YOU SAVE OVER \$3,700 IN LIFETIME WATER AND ENERGY COSTS.^{††}



SENSES WHEN ITEMS ARE DRY

Automatic Dryness Control uses a sensor to monitor air temperature, automatically stopping the cycle when fabrics are dry to help reduce shrinking and overdrying.



CLEAN WITH LESS WATER

A low-water wash system cleans efficiently with as little as 13 gallons of water. Rather than filling the basket, a concentrated detergent and water mix penetrates fabrics to help remove soils and stains.

Note: Not all features included on all models.

^{*}Based on the Consortium for Energy Efficiency qualifying product list. Visit cee1.org for more information. ^{**}Compared to pre-2004 traditional top-load washers.

[†]Compared to pre-2004 traditional dryers, average use, normal cycle, 12-year life. ^{††}Compared to pre-2004 traditional top-load pairs, average use, normal cycle, 11-year washer life and 12-year dryer life, combined washer and dryer water and energy savings, electric only.

MODEL LINEUP
TOP-LOAD WASHERS



3.6 CU. FT.
NTW4601B Q



3.6 CU. FT.
NTW4651B* Q



3.6 CU. FT.
NTW4701B Q



3.8 CU. FT.
NTW4750B* Q



TOP-LOAD DRYERS



6.5 CU. FT.
NE/GD4600Y Q



7.0 CU. FT.
NE/GD4700Y Q



For every Amana® major appliance sold, a tree will be planted to help rebuild global deforested areas.**

*Indicates a retail-specific model. **During 2014, for every major appliance it sells in the U.S., Amana® will donate \$0.10 (the cost of each tree planted). Total donation is expected to plant over 2 million trees.

SPECIFICATIONS

BOLD GREEN type indicates a step-up feature

TOP-LOAD WASHER	NTW4601B	NTW4651B*	NTW4701B	NTW4750B*
Matching Dryer	NE/GD4600Y	NE/GD4600Y	NE/GD4700Y	NE/GD4700Y
Capacity (cu. ft.)	3.6	3.6	3.6	3.8
ENERGY STAR® Qualified	—	—	—	Yes
High Efficiency	—	—	—	Yes
Spin Speed (RPM)	700	700	700	800
Number of Cycles	9	9	11	12
Bulky Items	Yes	Yes	Yes	Yes
Casual	Yes	Yes	Yes	Yes
Clean Washer w/ affresh® Washer Cleaner	Yes	Yes	Yes	Yes
Delicate	—	—	—	Yes
Drain & Spin	—	—	—	Yes
Handwash	—	—	Yes	—
Normal	Yes	Yes	Yes	Yes
Rinse & Spin	Yes	Yes	Yes	Yes
Soil Levels	3	3	3	3
Control Type	Electronic w/ Dials	Electronic w/ Dials	Electronic w/ Dials	Electronic w/ Dials
Automatic Temperature Control	Yes	Yes	Yes	Yes
Auto Load Sensing	—	—	—	Yes
Water Temperatures	3	3	4	5
Dispensers	Bleach	Bleach	Bleach, Fabric Softener	Bleach, Downy® Ball
Wash Basket	Spreckle Porcelain	Spreckle Porcelain	White Porcelain	Stainless Steel
Colors	Q	Q	Q	Q

TOP-LOAD DRYER	NE/GD4600Y	NE/GD4700Y
Matching Washer	NTW4601B & NTW4651B	NTW4701B & NTW4750B
Capacity (cu. ft.)	6.5	7.0
Number of Cycles	11	12
Air Dry	—	Yes
Cool Down	Yes	Yes
Heavy Duty Cycle	Yes	Yes
Less Dry	Yes	Yes
More Dry	Yes	Yes
Timed Dry Cycle	Yes	Yes
Temperature Options	3	4
Wrinkle Prevent Option	Yes	Yes
On/Off End-Of-Cycle Signal	—	Yes
Interior Drum Light	—	Yes
Automatic Dryness Control	Yes	Yes
Energy Preferred Cycle	Yes	Yes
Colors	Q	Q

COLOR



DIMENSIONS ARE SHOWN FOR PLANNING PURPOSES ONLY.

For complete information, see Installation Instructions packed with product.

TOP-LOAD WASHER

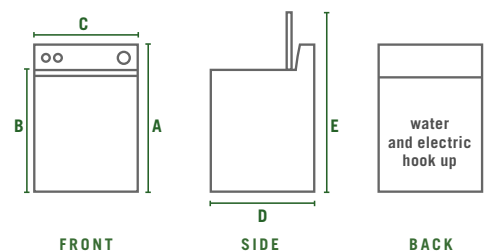

TOP-LOAD DRYER

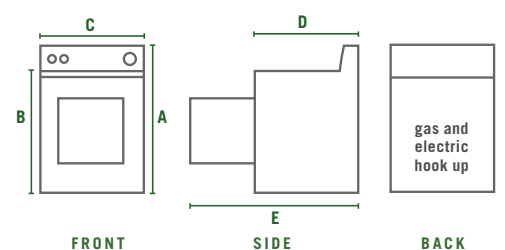

DIMENSIONS

MODEL	A OVERALL HEIGHT	B TOP HEIGHT	C OVERALL WIDTH	D OVERALL DEPTH	E LID/ DOOR OPEN 90°
NTW4601B	43"	36"	27"	28 1/5"	53 1/2"
NTW4651B	43"	36"	27"	28 1/5"	53 1/2"
NTW4701B	43"	36"	27"	28 1/5"	53 1/2"
NTW4750B	43"	36"	27"	28 1/5"	53 1/2"
NE/GD4600Y	43"	36"	27"	28 1/5"	51"
NE/GD4700Y	43"	36"	27"	28 1/5"	51"

*Indicates a retail-specific model.

ACCESSORIES



6' GOOSENECK NYLON BRAIDED FILL HOSE KIT

#8212638RC

#8212638RP

Nylon braided hose, 90° elbow with anti-corrosive couplings and pre-installed EPDM washers. Offers maximum water flow.



AFFRESH® WASHER CLEANER

#W10135699

Ideal for High-Efficiency washers, these tablets remove odor-causing residue and keep your machine fresher and cleaner when used monthly.



DRYER LINT BRUSH

#8212614

Maximize your drying experience by keeping lint screens clean. This handy brush is made for dryers with lint screens on top.



DRYER POWER CORDS

4', 3-WIRE, 30 AMP #PT220L

4', 4-WIRE, 30 AMP #PT400L

6', 3-WIRE, 30 AMP #PT500L

6', 4-WIRE, 30 AMP #PT600L

Successfully hook up your electric dryer with one of these industrial-grade cords. Includes (1) flexible, heavy-duty UL-listed cord with ring terminal connectors, adjustable strain relief bracket and installation instructions.



LAUNDRY 1-2-3™ ADJUSTABLE CLOTHES RACK

#XHS1000XX

Easily attaches with scratch-resistant magnets. Rotating arms pivot independently to accommodate various configurations.



MULTI-USE CLEANING BRUSH

#4210463RW

For dryers with a lint screen in front, this brush sweeps lint away so your clothes can dry more efficiently.



VENT INSTALLER KIT

#4396013RB

Keep it flowing with safe and efficient metal venting. A 4' vent section attaches to a close elbow, while another attaches to a wall offset. Plus, an extension collar takes it to greater lengths.



WASHABLE DELICATES BAG

#W10180464RP

Protect delicate items from snags, tangles and tears while machine washing and drying.

LAUNDRY GLOSSARY

AUTO LOAD SENSING

Automatically measures the size of the load and uses the optimal amount of water for the volume of clothing and cycle selected.

AUTOMATIC DRYNESS CONTROL

Monitors drying temperature and dryness level so you don't have to worry about your clothes overdrying.

AUTOMATIC TEMPERATURE CONTROL

Sensors monitor the flow of incoming water, adjusting as needed, to maintain the temperature you select for consistent cleaning.

CASUAL CYCLE

Used for non-iron fabrics like sport shirts, blouses, casual business clothes, permanent press items and blends.

CLEAN WASHER CYCLE

Use the Clean Washer cycle monthly to help remove detergent residue from inside the washer. Just add a cup of bleach—or, for a deeper clean, affresh® Washer Cleaner—to make your washer sparkle.

DELICATE CYCLE

Slow spin speeds and a gentle wash motion effectively clean delicate items.

DRAIN & SPIN CYCLE

Used to drain the washer or to drain and spin the wash load.

DRUM LIGHT

Improve the view. This light helps you see everything clearly as you load and unload.

EFFICIENCY MONITOR

Shows how the cycles and options you choose affect your overall energy savings.

END-OF-CYCLE SIGNAL

You'll hear the end of it. A signal lets you know when the cycle is complete.

ENERGY STAR® QUALIFIED

Save money on your monthly utility bills. ENERGY STAR® qualified washers use less water and energy and help put more spending money in your pocket.

EXTRA RINSE OPTION

Rinses soil and detergent thoroughly from clothes, minimizing irritation for those with sensitive skin.

FABRIC SOFTENER DISPENSER

Releases fabric softener at the right time during the wash cycle.

LOW WATER WASH SYSTEM

Impeller and wash basket move independently of each other, creating wash motions that provide better cleaning than agitator models and use less water.

NORMAL WASH CYCLE

The cycle for your everyday laundry needs. Choose from Regular, Heavy or Light Soil options.

PORCELAIN WASH BASKET

A smooth, porcelain surface resists scratches and tears, unlike plastic tub models, protecting fabrics from snags.

QUICK WASH SYSTEM

Increased spin speeds help remove more water for faster drying and help conserve water and energy.

REVERSIBLE-SWING DOOR

Quickly and conveniently load and unload clothes. Reversible doors create added installation versatility.

STAINLESS STEEL WASH BASKET

Resists scratches and rust to help prevent the staining of clothes.

WRINKLE PREVENT OPTION

Reduces wrinkles with an extended tumbling time to help prevent dry clothes from developing those pesky creases.

NOTES

A series of horizontal dotted lines for writing notes, spanning most of the page width.







DISHWASHERS

BETTER FOR YOUR WORLD AND YOUR WALLET

From sensors that help you clean to products that use less water and energy,* we're committed to helping you save both time and money. Now you can clean with a clean conscience.

*Compared to pre-2006 conventional dishwashers average use, normal cycle, 10-year life.



DISHWASHERS

PAGE 22



DISHWASHERS





A PLACE FOR LARGE DISHES

This **Tall Tub Interior** dishwasher features more room than a standard tub so you can wash more dishes in fewer loads, conserving water, energy and time.



FOR SPARKLING DISHES

Soil Sensors measure the soil level in each load and adjust the cycle time and water usage for just the right amount of energy and time.

SAVE MORE WHILE USING LESS

SKIP THE PREWASH. A TRIPLE FILTER WASH SYSTEM USES THREE FILTERS TO REMOVE EVEN TINY FOOD PARTICLES, HELPING YOU USE 35% LESS ENERGY, 62% LESS WATER AND SAVE OVER \$165* DURING THE APPLIANCE'S LIFETIME.



LEAVE THE DISH TOWEL ON THE RACK

The **heated dry option** whisks away moisture, so your dishes can go straight to the cupboard.

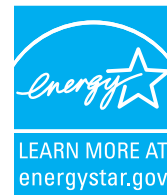

ENERGY STAR® QUALIFIED

Our tall tub dishwashers **meet or exceed the federal guidelines** for energy efficiency, so you can save money while conserving energy.

Note: Not all features included on all models.
*Compared to pre-2006 conventional dishwashers average use, normal cycle, 10-year life.

MODEL LINEUP
DISHWASHERS



ADB1100AW W/B/S



ADB1400PY W/B/S



For every Amana® major appliance sold, a tree will be planted to help rebuild global deforested areas.*

*During 2014, for every major appliance it sells in the U.S., Amana® will donate \$0.10 (the cost of each tree planted). Total donation is expected to plant over 2 million trees.

SPECIFICATIONS

BOLD GREEN type indicates a step-up feature

DISHWASHER	ADB1100AW	ADB1400PY
ENERGY STAR® Qualified	Yes	Yes
Triple Filter Wash System	Yes	Yes
Control Type	4" Console	2.5" Console
Tall Tub Interior	Yes	Yes
Tub Material	Plastic	Plastic
Rack Material	Vinyl	Vinyl
Twice as Nice™ silverware baskets w/ covers	—	2-In-the-Rack
Cup Shelves	—	2
Light Item Clips	—	4
Number of Cycles	3	3
Heavy Wash	Yes	Yes
Normal Wash	Yes	Yes
1-Hour Wash	Yes	Yes
Number of Options	2	5
Control Lockout	—	Yes
Delay Start	—	4-Hour
Heated Dry	Yes	Yes
High Temperature Wash	Yes	Yes
Soil Sensor	—	Yes
Rinse Aid Dispenser	Yes	Yes
Low Rinse Aid Indicator	Optical	Yes
Electronic Controls	Yes	Yes
Sound Package	—	Quiet Partner 1
Colors	W, B, S	W, B, S

COLORS



DIMENSIONS

MODEL	A OVERALL HEIGHT	B OVERALL WIDTH	C DEPTH INCLUDING CONSOLE	D DEPTH EXCLUDING CONSOLE	DEPTH W/ DOOR OPEN 90°	CUTOUT HEIGHT	CUTOUT WIDTH	CUTOUT DEPTH
ADB1100AW	33 1/2" – 34 1/2"	23 7/8"	25 1/4"	24 1/2"	49 3/4"	34"	24"	24"
ADB1400PY	33 1/2" – 34 1/2"	23 7/8"	25 1/4"	24 1/2"	49 3/4"	34"	24"	24"

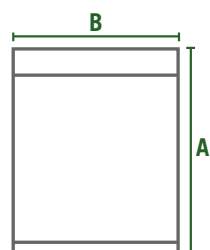

FRONT

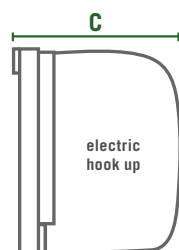

RIGHT SIDE

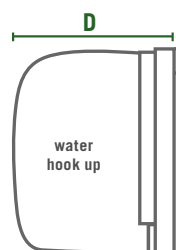

LEFT SIDE

DIMENSIONS ARE SHOWN FOR PLANNING PURPOSES ONLY.

For complete information, see Installation Instructions packed with product.

ACCESSORIES



AFFRESH® DISHWASHER CLEANER

#W10282479

Even the dishwasher needs a little freshening up. This cleaner uses environmentally safer ingredients to power away hard water mineral residue and is also safe to use with dishware.*



AFFRESH® KITCHEN & APPLIANCE CLEANER

#W10355010

Keep your kitchen clean and fresh. This formula cuts through everyday spills to leave a streak-free shine.



DISHWASHER RACK REPAIR KIT

#4396838RC (WHITE RACKS)

#4396840RC (GRAY RACKS)

Easily cover small cuts or exposed portions of the rack. Plus, this kit includes rack tine tips for an appearance that looks like new.



DISHWASHER SWIVEL GOOSENECK FITTING

#W10685193

Use this brass fitting with a pre-installed EPDM washer to connect your dishwasher to the water supply line. It is necessary for installation of all Amana® dishwashers produced after 2009.



UNIVERSAL INDUSTRIAL- GRADE 6' DISHWASHER WATER SUPPLY KIT

#W10278636RC

#W10278635RP

Connect your dishwasher to the water supply with this kit. The braided reinforced hose is better than stainless steel. Kit also includes (2) 3/8-inch brass compression fittings, (1) 3/8-inch brass elbow and (1) 3/4-inch brass swivel gooseneck fitting.

DISHWASHER GLOSSARY

1-HOUR WASH CYCLE

Rapidly clean lightly soiled items, like glassware.*

CONTROL LOCKOUT

Locks controls to prevent unintended use.

CUP SHELVES

Allows you to load two tiers of cups or other small items.

DELAY START OPTION

Lets you program the wash cycle to run during off-peak use hours** or when you're away from the kitchen.

ELECTRONIC CONTROLS

Flat controls keep cycle selection simple and wipe clean with ease.

HEATED DRY OPTION

An internal heater accelerates the drying process, removing excess moisture so you can forgo the dish towel.

HIGH TEMPERATURE WASH OPTION

A heater boosts the water temperature during the wash cycle. Plus, an extra rinse is added for enhanced cleaning and drying.

LIGHT ITEM CLIPS

Clips help hold small pieces in place so they're easy to locate and put away.

RINSE AID DISPENSER WITH INDICATOR

Automatically adds a measured amount during the wash cycle, reducing the potential for spots on your dishes. Plus, an indicator helps you keep track of when a refill is needed.

SOIL SENSORS

Sensors adjust cycle time and water usage to match the soil level in each load, helping save time and energy.

TALL TUB INTERIOR

Holds more dishes and provides room for items that are too big to fit in a standard dishwasher tub.

TRIPLE FILTER WASH SYSTEM

A combination of three filters removes even tiny food particles from the wash water, so you conserve energy and water and still get clean dishes.

NOTES

A series of horizontal dotted lines for writing notes, spanning the width of the page.







COOKING

TAILOR ENERGY USAGE TO THE DISH

Our cooking appliances are consistent in temperature and efficient when using the right pan with the right burner to provide a more precise experience. So whether you're crafting an entire family meal or just warming up soup, you've got the right tools to cook to perfection.





GAS RANGES

PAGE 32



ELECTRIC RANGES

PAGE 36



MICROWAVES & VENTS

PAGE 40

GAS RANGES





KEEP SPILLS CONTAINED

Don't sweat the small spills. **Sealed Burners** make cleanup easy by preventing spills from dripping beneath the cooktop.



MAKE WAY FOR LARGE DISHES

The **EasyAccess™ Broiler Door** spans the width of the oven, allowing large dishes to move smoothly from oven to broiler, rack and all.

HANDLES THE DIRTY WORK

THE HIGH/LOW SELF-CLEANING OVEN LETS YOU SELECT THE RIGHT AMOUNT OF CLEANING FOR LIGHT OR HEAVY SOILS.



A DELICIOUS VIEW

The **Extra-Large Oven Window** allows you to keep track of dinner without having to disturb the temperature by opening the door.



IT'S ALL UNDER CONTROL

Easy Touch Electronic Oven Controls allow you to set bake and broil temperatures with the touch of a finger. A clock and timer make it convenient to count down to dinner time, while the oven control lockout prevents unintended use.

MODEL LINEUP
30" GAS RANGES



5.1 CU. FT.
AGR4230BA W/B



5.1 CU. FT.
AGR5330BA W/B/S



5.0 CU. FT.
AGR5630BD W/B/S

20" GAS RANGE



2.6 CU. FT.
AGG22VD W/B



For every Amana® major appliance sold, a tree will be planted to help rebuild global deforested areas.*

*During 2014, for every major appliance it sells in the U.S., Amana® will donate \$0.10 (the cost of each tree planted). Total donation is expected to plant over 2 million trees.

SPECIFICATIONS

BOLD GREEN type indicates a step-up feature

GAS RANGE	AGR4230BA	AGR5330BA	AGR5630BD	AGG222VD
Size	30"	30"	30"	20"
Oven Capacity (cu. ft.)	5.1	5.1	5.0	2.6
Matching Over-the-Range Microwave	AMV2175C AMV1150VA	AMV2175C AMV1150VA	AMV2175C AMV1150VA	—
Included LP Gas Conversion Kit	Yes	Yes	Yes	Yes
Towel Bar Door Handle	Yes	Yes	Yes	Yes
Oven Features				
Oven Controls	Knob Control	Easy Touch Electronic	Easy Touch Electronic	Knob Control
Oven Window	—	Extra-Large	Extra-Large	Yes
Self-Cleaning	—	—	High/Low	—
Interior Oven Light	—	Yes	Yes	Yes
Oven Racks	2	2	2	2
Oven Rack Positions	5	5	5	5
Storage Drawer	—	—	Yes	—
Oven Control Lockout	—	Yes	Yes	—
Broiler	EasyAccess™ Broiler w/ Wide-Broil Rack	EasyAccess™ Broiler w/ Wide-Broil Rack	In-Oven Broiler	Drop-Down Broiler w/ Pan
Cooktop Features				
Electronic Clock w/ Timer	—	Yes	Yes	—
Spillsaver™ Upswept Cooktop	Porcelain-Steel	Porcelain-Steel	Porcelain-Steel	Wire Steel
Burner Type	(4) 9,500 BTU Sealed Burners	(3) 9,500 BTU (1) 11,500 BTU Sealed Burners	(1) 5,000 BTU (2) 9,500 BTU (1) 12,500 BTU Sealed Burners	(2) 7,000 BTU (2) 9,500 BTU Sealed Burners
Grates	Porcelain-Coated Steel	Porcelain-Coated Steel	Porcelain-Coated Steel	Porcelain-Coated Steel
Colors	W, B	W, B, S	W, B, S	W, B

COLORS

	W White		B Black		S Stainless Steel w/ black cabinet and cooktop
---	-------------------	---	-------------------	---	---

DIMENSIONS

MODEL	A OVERALL HEIGHT	B OVERALL WIDTH	C HEIGHT TO COOKTOP	D DEPTH EXCLUDING HANDLE	E DEPTH INCLUDING HANDLE	DEPTH W/ DOOR OPEN 90°	CUTOUT HEIGHT	CUTOUT WIDTH	CUTOUT DEPTH
AGR4230BA	46 1/4"	29 22/25"	36"	25 1/10"	27 1/5"	45 1/5"	36 1/50"	30 1/8"	24"
AGR5330BA	46 1/4"	29 22/25"	36"	25 1/10"	27 1/5"	45 1/5"	36 1/50"	30 1/8"	24"
AGR5630BD	46 7/8"	29 7/8"	36"	25 7/16"	27 7/8"	46 11/16"	36"	30"	24"
AGG222VD	42"	19 3/4"	36"	24 1/2"	26 1/4"	42 1/8"	36"	20 1/8"	24"

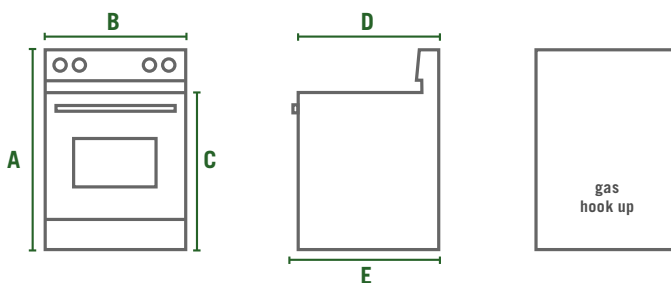

**DIMENSIONS ARE SHOWN
FOR PLANNING PURPOSES ONLY.**

For complete information, see Installation
Instructions packed with product.

ELECTRIC RANGES





EASY CLEANUP

Our **Spillsaver™ ceramic glass cooktops** feature raised edges and smooth surfaces to help make spills and splashes a breeze to clean.



THE WHOLE MEAL FITS

A **large capacity** means you can cook multiple dishes at once and handle everything from daily meals to big family dinners with ease.

ENJOY EATING IN AGAIN

WITH A VERSATILE COOKTOP THAT HEATS WITH PRECISION,
PLUS EASY CLEANUP, YOU'LL LOVE COOKING AT HOME AGAIN.



PRECISION AT EVERY TEMPERATURE

A **versatile cooktop** with multiple elements provides precise control so you can prepare food while using the right amount of energy for the dish.



IT'S ALL UNDER CONTROL

Easy Touch electronic oven controls allow you to set bake and broil temps with the touch of a finger. A clock and timer make it convenient to count down to dinner time, while control lockout prevents unintended use.

MODEL LINEUP

30" ELECTRIC RANGES



4.8 CU. FT.
ACR3130BA W



4.8 CU. FT.
ACR4530BA W/B



4.8 CU. FT.
AER5330BA W/B/S



4.8 CU. FT.
AER5630BA W/B/S

20" ELECTRIC RANGE



2.6 CU. FT.
AEP222VA W



For every Amana® major appliance sold, a tree will be planted to help rebuild global deforested areas.*

*During 2014, for every major appliance it sells in the U.S., Amana® will donate \$0.10 (the cost of each tree planted). Total donation is expected to plant over 2 million trees.

SPECIFICATIONS

BOLD GREEN type indicates a step-up feature

ELECTRIC RANGE	ACR3130BA	ACR4530BA	AER5330BA	AER5630BA	AEP222VA
Size	30"	30"	30"	30"	20"
Oven Capacity (cu. ft.)	4.8	4.8	4.8	4.8	2.6
Matching Over-the-Range Microwave	AMV2175C AMV1150VA	AMV2175C AMV1150VA	AMV2175C AMV1150VA	AMV2175C AMV1150VA	—
Towel Bar Door Handle	Yes	Yes	Yes	Yes	Yes
Oven Features					
Oven Controls	Knob Control	Easy Touch Electronic	Easy Touch Electronic	Easy Touch Electronic	Knob Control
Oven Window	—	Standard	Extra-Large	Extra-Large	Large
Self-Cleaning	—	Adjustable Time	—	Adjustable Time	—
Interior Oven Light	—	Yes	Yes	Yes	Yes
Oven Racks	2	2	2	2	2
Oven Rack Positions	5	5	5	5	5
Storage Drawer	Yes	Yes	Yes	Yes	—
Oven Control Lockout	—	Yes	Yes	Yes	Yes
In-Oven Broiler	Yes	Custom	Custom	Custom	Yes
Delay-Bake Oven Control	—	—	Yes	Yes	—
Temp Assure™ Cooking System	—	—	Yes	Yes	Yes
Keep Warm™ Setting	—	—	Yes	Yes	—
Cooktop Features					
Electronic Clock w/ Timer	—	Yes	Yes	Yes	—
Spillsaver™ Upswept Cooktop	Porcelain-Steel	Porcelain-Steel	Glass-Ceramic	Glass-Ceramic	Porcelain-Steel
Chrome Drip Bowls	Yes	Yes	—	—	Yes
Element Type	Coil Element: (2) 6" 1,250-watt (2) 8" 2,100-watt	Coil Element: (2) 6" 1,250-watt (2) 8" 2,100-watt	Radiant Element: (2) 6" 1,500-watt (2) 8" 2,000-watt	Radiant Element: (2) 6" 1,200-watt (1) 8" 1,800-watt (1) 9"6" 3,000/1,400-watt	Coil Element: (3) 6" 1,250-watt (1) 8" 2,100-watt
Element On/Hot Indicator Light	On Indicator Only	On Indicator Only	On/Hot Indicators	On/Hot Indicators	On Indicator Only
Colors	W	W, B	W, B, S	W, B, S	W

COLORS



DIMENSIONS

MODEL	A OVERALL HEIGHT	B OVERALL WIDTH	C HEIGHT TO COOKTOP	D DEPTH EXCLUDING HANDLE	E DEPTH INCLUDING HANDLE	DEPTH W/ DOOR OPEN 90°	CUTOUT HEIGHT	CUTOUT WIDTH	CUTOUT DEPTH
ACR3130BA	46 7/8"	29 7/8"	36"	25 5/16"	27 3/4"	46 11/16"	36"	30"	24"
ACR4530BA	46 7/8"	29 7/8"	36"	25 5/16"	27 3/4"	46 11/16"	36"	30"	24"
AER5330BA	46 7/8"	29 7/8"	36"	25 5/16"	27 3/4"	46 11/16"	36"	30"	24"
AER5630BA	46 7/8"	29 7/8"	36"	25 5/16"	27 3/4"	46 11/16"	36"	30"	24"
AEP222VA	42 9/16"	19 3/4"	36"	24 1/2"	26 1/4"	42 1/8"	36"	20 1/8"	24"

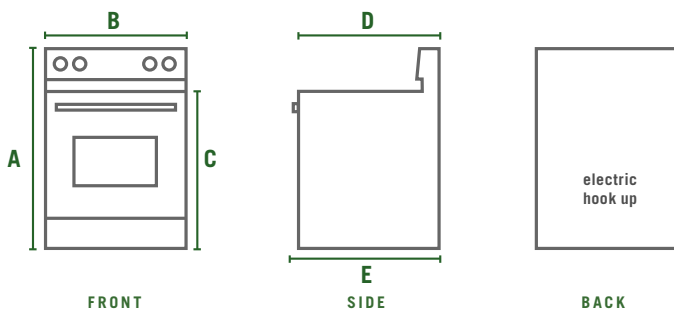

DIMENSIONS ARE SHOWN FOR PLANNING PURPOSES ONLY.

For complete information, see Installation Instructions packed with product.

MICROWAVES AND VENTS





PROGRAM WITH EASE

Touchmatic® control systems and simple keypads make it easy to choose the right cooking options.



TASTY RESULTS

Cook and reheat without the worry of overcooking. **Automatic sensors** monitor humidity levels and automatically adjust cooking time and temperature for delicious results.

POWERS DOWN WHEN YOU DO

MANY APPLIANCES DRAW POWER WHEN NOT IN USE. OUR ENERGY SETTING CUTS ELECTRICITY TO THE MICROWAVE, SO WHEN YOU'RE OUT FOR THE DAY OR JUST NOT USING THE MICROWAVE, IT'S HELPING CONSERVE ENERGY.



CLEAR THE AIR

Hidden vents provide a sleek look and easy clean up. Ventilation options include recirculation and exterior venting models.



EVEN A CASSEROLE DISH FITS

Our **microwave interiors** easily hold and effectively heat your favorite recipes, even in a 9" x 13" dish.

MODEL LINEUP

OVER-THE-RANGE MICROWAVES



1.5 CU. FT.

AMV1150VA W/B/S



1.7 CU. FT.

AMV2175C W/B/S



For every Amana® major appliance sold, a tree will be planted to help rebuild global deforested areas.*

*During 2014, for every major appliance it sells in the U.S., Amana® will donate \$0.10 (the cost of each tree planted). Total donation is expected to plant over 2 million trees.

SPECIFICATIONS

BOLD GREEN type indicates a step-up feature

OVER-THE-RANGE MICROWAVE	AMV1150VA	AMV2175C
Capacity (cu. ft.)	1.5	1.7
Power Output (Watts)	1,000	1,000
CFM Rating	220	220
Display w/ Digital Clock & Timer	Yes	Yes
Variable Power Levels	10	10
Touchmatic® Control System	Yes	Yes
Wire Rack	—	Yes
Turntable	Extra-Large	Extra-Large
Interior Light	Yes	Yes
Cooktop Surface Light	Yes, w/ Timer Delay	Yes, w/ Timer Delay
Control Lockout	Yes	Yes
Exhaust Fan	Yes	Yes
Energy Saver Setting	—	Yes
Sensor Technology	—	Yes
Auto Defrost	Yes	Yes
Auto Cook	Yes	Yes
Auto Reheat	Yes	Yes
End of Cycle Signal	Yes	Yes
One Touch Key	Add-a-Minute	Add-30-Seconds
Vent	Hidden	Hidden
Grease Filter	W10208631	W10208631
Charcoal Filter	8206230A	8206230A
Colors	W, B, S	W, B, S

COLORS



DIMENSIONS

MODEL	A OVERALL HEIGHT	B OVERALL WIDTH	C OVERALL DEPTH	CUTOUT WIDTH	MINIMUM INSTALL HEIGHT
AMV1150VA	17 1/4"	29 15/16"	15 3/8"	30"	66"
AMV2175C	17 1/4"	29 15/16"	16 1/8"	30"	66"

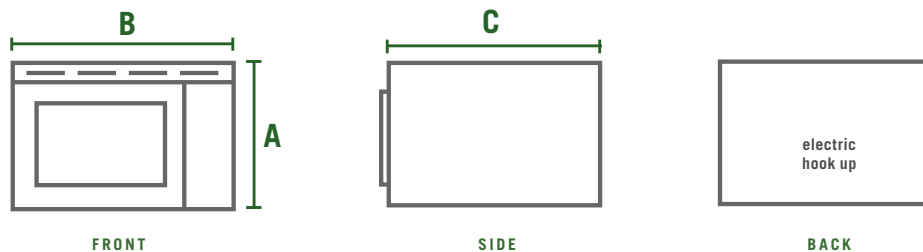

DIMENSIONS ARE SHOWN FOR PLANNING PURPOSES ONLY.

For complete information, see Installation Instructions packed with product.

UNIVERSAL MICROWAVE FILLER KITS

MODEL	8171336	8171337	8171339	99401	99402
Opening Size	36"	36"	36"	—	—
Color	W	B	S	B Plastic	W Plastic

MODEL LINEUP

VENTILATION HOODS



UP TO
190 CFM

UXT2030AD - 30" MODEL
W / B



UP TO
190 CFM

UXT3030AD - 30" MODEL
W / B



UP TO
190 CFM

UXT4030AD - 30" MODEL
W / B / S
UXT4036AD - 36" MODEL
W / B



UP TO
190 CFM

UXT4130AD - 30" MODEL
UXT4136AD - 36" MODEL
W / B / S



UP TO
225 CFM

UXT4230AD - 30" MODEL
UXT4236AD - 36" MODEL
W / B / S



UP TO
350 CFM

UXT5230BD - 30" MODEL
W / B / S
UXT5236BD - 36" MODEL
S



UP TO
400 CFM

UXT5530AA - 30" MODEL
UXT5536AA - 36" MODEL
S



FIT SYSTEM

The FIT system* eliminates measuring, cutting and filler strips for a perfect fit every time.**



For every Amana® major appliance sold, a tree will be planted to help rebuild global deforested areas.***

*Does not include UXT5530AA or UXT5536AA.

**Based on typical installation with existing electrical and ventilation connections.

***During 2014, for every major appliance it sells in the U.S., Amana® will donate \$0.10 (the cost of each tree planted). Total donation is expected to plant over 2 million trees.

SPECIFICATIONS

BOLD GREEN type indicates a step-up feature

VENTILATION	UXT2030AD	UXT3030AD	UXT4030AD	UX4130AD	UXT4230AD	UXT5230BD	UXT5530AA
Size	30"	30"	30"	30"	30"	30"	30"
Also available in 36"	—	—	UXT4036AD	UXT4136AD	UXT4236AD	UXT5236BD	UXT5536AA
Exhaust (Max.)	190 CFM	190 CFM	190 CFM	190 CFM	225 CFM	350 CFM	400 CFM
Sones (Sound Rating)	up to 4.5	up to 4.5	N/A Recirculating Only	up to 4.5	up to 6.4	up to 7	up to 8
Controls	2-Speed Rocker Switch	2-Speed Rocker Switch	2-Speed Rocker Switch	2-Speed Rocker Switch	Variable Speed, Rotary	3-Speed, Push Button	3-Speed, Push Button
Lighting	75-Watt On/Off Incandescent	75-Watt On/Off Incandescent	75-Watt On/Off Incandescent	75-Watt On/Off Incandescent	75-Watt On/Off Incandescent	50-Watt On/Off Halogen	50-Watt On/Off Halogen
Fan	Axial	Axial	Axial	Axial	Axial	Axial	High-Performance Centrifugal
Recirculation Kit (Ductless) w/ Charcoal Filter	—	—	Included Charcoal Filter (W10355450)	Optional (W10355450)	Optional (W10355450)	Optional (W10386873)	Included Charcoal Filter (W10272068)
Duct Type	7" Round	3 1/4" x 10" Rectangular	N/A Recirculating Only	7" Round or 3 1/4" x 10" Rectangular	7" Round or 3 1/4" x 10" Rectangular	7" Round or 3 1/4" x 10" Rectangular	6" Round or 3 1/4" x 10" Rectangular
Venting	Exterior, Top	Exterior, Top & Rear	N/A Recirculating Only	Convertible: Exterior or Recirculating	Convertible: Exterior or Recirculating	Convertible: Exterior or Recirculating	Convertible: Exterior or Recirculating
Damper	Optional 7" Round (W10355451)	3 1/4" x 10" Rectangular	N/A Recirculating Only	Optional 7" Round (W10355451)	Optional 7" Round (W10355451)	Optional 7" Round (W10355451)	Optional 7" Round (W10355451)
Power Cord (3 ft., 115V, 3 Wire)	Optional (W10613691)	Optional (W10613691)	Optional (W10613691)	Optional (W10613691)	Optional (W10613691)	Optional (W10613691)	Included
Grease Filter	W10395127	W10395127	—	W10395127	W10395127	—	W10419114
Colors	W, B	W, B	W, B, S (36" model in W, B only)	W, B, S	W, B, S	W, B, S (36" model in S only)	S

COLORS



DIMENSIONS

MODEL	A OVERALL HEIGHT	B OVERALL WIDTH	C DEPTH	CABINET WIDTH	MIN INSTALL HEIGHT FROM COOKING SURFACE (ELECTRIC-GAS)	DUCT TYPE
UXT2030AD	4 15/16"	29 15/16"	18 5/8"	30"	18-24"	7" Round
UXT3030AD	4 15/16"	29 15/16"	18 5/8"	30"	18-24"	3 1/4" x 10" Rectangular
UXT4030AD	4 15/16"	29 15/16"	18 5/8"	30"	18-24"	No External Venting, Recirculating Only
UXT4036AD	4 15/16"	35 15/16"	18 5/8"	36"	18-24"	No External Venting, Recirculating Only
UX4130AD	4 15/16"	29 15/16"	18 5/8"	30"	18-24"	7" Round or 3 1/4" x 10" Rectangular
UX4136AD	4 15/16"	35 15/16"	18 5/8"	36"	18-24"	7" Round or 3 1/4" x 10" Rectangular
UXT4230AD	4 15/16"	29 15/16"	18 5/8"	30"	18-24"	7" Round or 3 1/4" x 10" Rectangular
UXT4236AD	4 15/16"	29 15/16"	18 5/8"	36"	18-24"	7" Round or 3 1/4" x 10" Rectangular
UXT5230BD	4 15/16"	29 15/16"	18 5/8"	30"	18-24"	7" Round or 3 1/4" x 10" Rectangular
UXT5236BD	4 15/16"	29 15/16"	18 5/8"	36"	18-24"	7" Round or 3 1/4" x 10" Rectangular
UXT5530AA	9"	29 7/8"	19 3/4"	30"	18-24"	6" Round or 3 1/4" x 10" Rectangular
UXT5536AA	9"	35 7/8"	19 3/4"	36"	18-24"	6" Round or 3 1/4" x 10" Rectangular

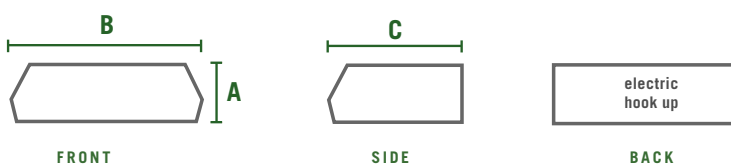

DIMENSIONS ARE SHOWN FOR PLANNING PURPOSES ONLY.

For complete information, see Installation Instructions packed with product.

ACCESSORIES



4' GAS RANGE CONNECTOR KIT

#30-48KITRC

This kit has everything you need to hook up your gas range. Includes (1) 4' connector, (3) fittings, sealant, leak detector solution and installation instructions.



AFFRESH® COOKTOP CLEANER (10 FL. OZ.)

#W10355051

Cuts through tough, baked-on residue. Safe for all glass, ceramic and porcelain cooktops.



AFFRESH® STAINLESS STEEL CLEANER (16 FL. OZ.)

#W10355016

Gently cleans fingerprints, smudges and residue to leave a streak-free, polished shine.



PREMIUM BROIL PAN & ROASTING RACK

#W10123240

This easy-to-clean, 3-piece set with broiler grid helps prevent splatters and smoke.



RANGE ANTI-TIP KIT

#8273888A

Attaches to floor to minimize movement of ranges. Installation instructions included.



RANGE POWER CORDS

6', 4-WIRE, 40 AMP #PT600

4', 4-WIRE, 40 AMP #PT400

4', 3-WIRE, 40 AMP #PT220

Successfully hook up your electric range with one of these industrial-grade cords, and you'll be cooking in no time.



UNIVERSAL MICROWAVE STEAMER

#8205262RB

Use these dishwasher-safe, hard plastic components to steam fish, vegetables or rice.



VENTILATION HOOD POWER CORD

5', 3-WIRE, 125 VOLT #W10355452

3', 3-WIRE, 115 VOLT #HOODPT3

Hook up your vent hood with ease with the choice of a 5' or 3' power cord.

COOKING GLOSSARY

AUTO COOK

Heats frozen entrees, beverages and instant rice with the touch of a button.

AUTO DEFROST

Effectively thaws food according to weight for meals in a hurry.

AUTO REHEAT

Preset programs reheat items like a full dinner plate or a slice of pizza.

CHARCOAL ODOR FILTER

Helps pull cooking odors out of the kitchen air.

CONTROL LOCKOUT

Locks controls so little fingers can't turn on the range or the microwave oven.

CUSTOM BROIL

Set the broil temperature in five-degree increments. Choose higher heat for meat and lower heat for delicate desserts.

DELAY-BAKE OVEN CONTROL

This control lets you program the oven to be ready when you are.

EASY TOUCH ELECTRONIC OVEN CONTROLS

Set bake or broil temperatures with just a touch. Plus, a clock and timer make it easy to count down to dinner time. Control lockout prevents unintended use.

FIT SYSTEM

This system eliminates measuring, cutting and filler strips on under-cabinet hoods for a perfect fit every time.*

HIDDEN VENT

Ventilation performance that's sleek and easy to maintain. A charcoal odor filter eliminates cooking odors.

KEEP WARM™ SETTING

Maintains the temperature of finished food without cooking it further.

LP GAS CONVERTIBLE

Included hardware that converts your gas range for use with propane gas.

SEALED BURNERS

Makes cleanup easy by preventing spills from dripping beneath the cooktop.

SELF-CLEANING OVEN

Let the oven do the dirty work. Select models feature adjustable cleaning time.

SENSOR TECHNOLOGY

Monitors humidity and automatically adjusts microwave cooking time so food is cooked or reheated, but not overcooked.

SPILLSAVER™ CERAMIC GLASS COOKTOP

A smooth, seamless ceramic and glass surface that contains spills for easy cleanup.

SPILLSAVER™ UPSWEPT COOKTOP

A smooth, seamless porcelain-steel surface that contains spills for easy cleanup.

TEMP ASSURE™ COOKING SYSTEM

Keeps temperatures consistent with a preheat cycle and dual use of the bake and broil elements.

TOUCHMATIC® CONTROL SYSTEM

Program your microwave with ease thanks to this simple keypad.

*Based on typical installation with existing electrical and ventilation connections. Consult a professional installer to ensure your installation complies with code requirements.

NOTES

A series of horizontal dotted lines for writing notes, spanning the width of the page.







REFRIGERATORS

SMALLER FOOTPRINT. BIGGER SAVINGS.

Large capacities, adjustable door bins and lower energy usage—they're just a few of the ways new Amana® refrigerators are standing tall to help you conserve resources, save money and prevent wasted space.



SIDE-BY-SIDE

PAGE 52



BOTTOM FREEZER

PAGE 56



TOP FREEZER

PAGE 60

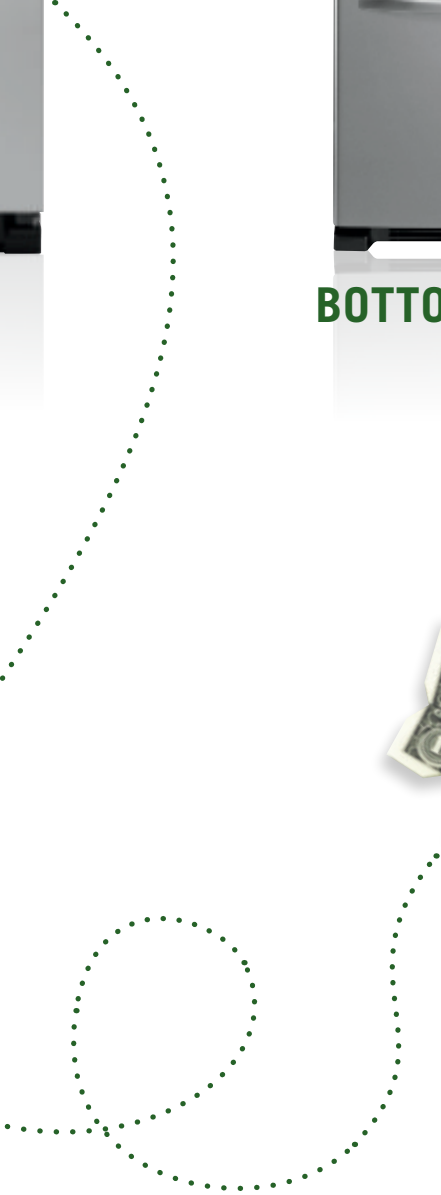

SIDE-BY-SIDE REFRIGERATORS





FILTERED WATER WHEN YOU WANT IT

A **PUR® Water Filtration System** dispenses cold, refreshing water straight from the refrigerator and can save you up to \$600 a year instead of buying bottled water.*



STRESS-FREE MESSSES

Save yourself the trouble. **Spillsaver™ Glass Shelves** help keep the mess contained and they're adjustable, too!

ECO-CONSCIOUS, BUDGET-FRIENDLY

OUR SLEEK AND EFFICIENT SIDE-BY-SIDE REFRIGERATORS USE 30% LESS ENERGY

TO KEEP FOOD COOL, HELPING YOU SAVE \$300 DURING THEIR LIFETIME.**



ADJUSTS TO FIT YOUR NEEDS

From gallon door bins to a full-width crisper drawer, our **versatile storage options** are designed to fit what you bring home from the market.



ROOM TO CHOOSE

With a capacity of over **23 cu. ft.** in our Amana® side-by-side refrigerators, you always have the food storage space that's right for you.

Note: Not all features included on all models.

*Based on average use of two 6-month, 200-gallon water filters versus purchasing the same amount of leading brand bottled water.

**Compared to the average annual energy usage of a pre-2000 refrigerator, based on average use, 12-year life.

MODEL LINEUP

SIDE-BY-SIDE REFRIGERATORS



21 CU. FT.
ASD2275BR W/B/S



24 CU. FT.
ASD2575BR W/B/S



For every Amana® major appliance sold, a tree will be planted to help rebuild global deforested areas.*

*During 2014, for every major appliance it sells in the U.S., Amana® will donate \$0.10 (the cost of each tree planted). Total donation is expected to plant over 2 million trees.



SPECIFICATIONS

BOLD GREEN type indicates a step-up feature

SIDE-BY-SIDE REFRIGERATOR	ASD2275BR	ASD2575BR
Capacity (cu. ft.)	21	24
Total Shelf Area (sq. ft.)	21	23.9
Controls	Electronic Temp Assure™ Freshness Controls	Electronic Temp Assure™ Freshness Controls
External Dispenser w/ PUR® Water and Ice Filter	Yes	Yes
Replacement Water Filter	W10295370	W10295370
Filter Status Indicator	Yes	Yes
SofSound™ Sound Package	Yes	Yes
Refrigerator Storage		
Refrigerator Capacity (cu. ft.)	14.45	15.32
Clear, Humidity-Controlled Garden Fresh™ Crisper Drawer	1	1
Adjustable Spillsaver™ Glass Shelves	3	3
Door Bins	4 White, Adjustable	3 White, Adjustable
Door Bin Grip Pads	4	4
Gallon Door Storage	Yes	Yes
Dairy Center	Covered	Covered
Freezer Storage		
Freezer Capacity (cu. ft.)	6.77	9.17
Factory-Installed Automatic Ice Maker	Yes	Yes
Door Style	Flat	Flat
Colors	W, B, S	W, B, S

COLORS

	W White Textured door finish		B Black Textured door finish		S Stainless Steel Smooth door finish, black cabinet, metal handles
---	---	---	---	--	---

DIMENSIONS

MODEL	A HEIGHT W/ HINGE	B HEIGHT EXCLUDING HINGE	C CABINET WIDTH	D DEPTH W/ HANDLE	E DEPTH EXCLUDING HANDLE	F DEPTH W/ DOOR OPEN 90°
ASD2275BR	66 1/4"	65 7/8"	32 3/4"	34 5/8"	32 3/8"	49 7/8"
ASD2575BR	69 1/8"	68 7/8"	35 1/2"	34 1/2"	32 3/8"	49 7/8"

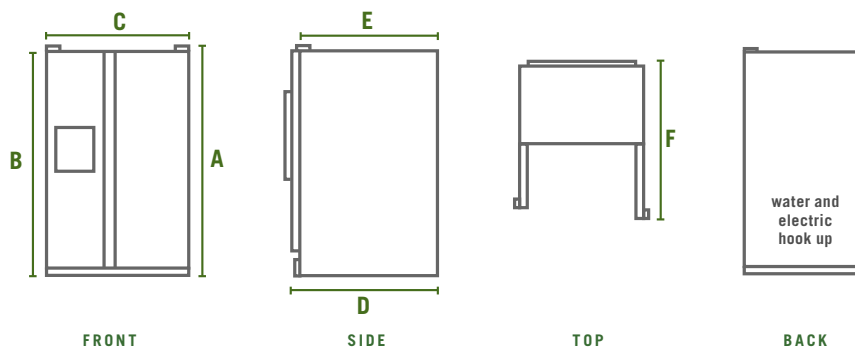

**DIMENSIONS ARE SHOWN
FOR PLANNING PURPOSES ONLY.**

For complete information, see Installation Instructions packed with product.

BOTTOM-FREEZER REFRIGERATORS





FIT MORE IN THE DOOR

With **gallon-size shelves** and adjustable bins, there's always a perfect place for those gallons of milk, 2-liter bottles and juice containers—whatever quenches your thirst.



STRESS-FREE MESSSES

Save yourself the trouble. **Spillsaver™ Glass Shelves** help keep the mess contained and they're adjustable, too!

CONSERVE ENERGY, SAVE MONEY

OUR BOTTOM-FREEZER REFRIGERATORS HELP YOU CONSERVE 42% ENERGY AND SAVE UP TO \$400 DURING THEIR LIFETIME.*



ADJUSTS TO FIT YOUR NEEDS

From humidity-controlled crisper drawers to gallon door bins, our **versatile storage options** are designed to fit what you bring home.



TAKE CONTROL OF FOOD STORAGE

Easy-to-use **Temp Assure™ freshness controls** put consistent temperatures right at your fingertips for worry-free food storage.

Note: Not all features included on all models.

*Compared to average annual energy use of a pre-2000 refrigerator, based on average use, 12-year life.

MODEL LINEUP

BOTTOM-FREEZER REFRIGERATORS

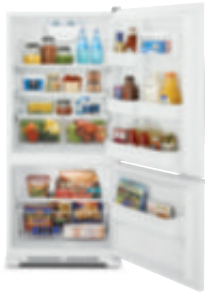

18.7 CU. FT.
ABB1921BR W/B/M



18.7 CU. FT.
ABB1924BR W/B/M



22.1 CU. FT.
ABB2224BR W/B/M



For every Amana® major appliance sold, a tree will be planted to help rebuild global deforested areas.*

*During 2014, for every major appliance it sells in the U.S., Amana® will donate \$0.10 (the cost of each tree planted). Total donation is expected to plant over 2 million trees.



SPECIFICATIONS

BOLD GREEN type indicates a step-up feature

BOTTOM-FREEZER REFRIGERATOR	ABB1921BR	ABB1924BR	ABB2224BR
Capacity (cu. ft.)	18.7	18.7	22.1
Total Shelf Area (sq. ft.)	20.0	20.0	23.5
Temp Assure™ Freshness Controls	Yes	Yes	Yes
Reversible-Swing Doors	Yes	Yes	Yes
EasyReach™ Freezer Door	Yes	—	—
EasyFreezer™ Pull-Out Drawer	—	Yes	Yes
Refrigerator Storage			
Refrigerator Capacity (cu. ft.)	12.94	12.94	15.6
Clear, Humidity Controlled Garden Fresh™ Crisper Drawers	2	2	2
Deli Drawer	—	1 Half-Width	1 Half-Width
Adjustable Glass Shelves	2 Full-Width	4 Half-Width Spillsaver™	4 Half-Width Spillsaver™
Door Bins	3 Adjustable	4 Adjustable	4 Adjustable
Gallon Door Storage	Yes	Yes	Yes
Dairy Center	Covered	Covered	Covered
Freezer Storage			
Freezer Capacity (cu. ft.)	5.73	5.73	6.45
Optional Automatic Ice Maker	Kit IC13B	Kit IC13B	Kit IC13B
Shelves	1 Upper Wire	—	—
EasyClose™ Freezer Drawer System	—	Yes	Yes
Baskets	1 Glide-Out Wire Lower w/ QuickSplit™ Organizer	2 Wire, 1 Lower w/ QuickSplit™ Organizer	2 Wire, 1 Lower w/ QuickSplit™ Organizer
Door Style	Flat	Flat	Flat
Colors	W, B, M	W, B, M	W, B, M

COLORS

	W White Textured door & drawer finish		B Black Textured door & drawer finish		M Monochromatic Stainless Steel Smooth door & drawer finish
---	--	---	--	--	--

DIMENSIONS

MODEL	A HEIGHT W/ HINGE	B HEIGHT EXCLUDING HINGE	C CABINET WIDTH	D DEPTH W/ HANDLE	E DEPTH EXCLUDING HANDLE	F DEPTH W/ DOOR OPEN 90°
ABB1921BR	66 ¹⁵ / ₁₆ "	65 ¹ / ₂ "	29 ⁵ / ₈ "	33 ³ / ₈ "	30 ⁷ / ₈ "	59"
ABB1924BR	66 ¹⁵ / ₁₆ "	65 ¹ / ₂ "	29 ⁵ / ₈ "	33 ³ / ₈ "	30 ⁷ / ₈ "	59"
ABB2224BR	69 ¹⁵ / ₁₆ "	68 ¹ / ₂ "	32 ⁵ / ₈ "	33 ³ / ₈ "	30 ⁷ / ₈ "	62"

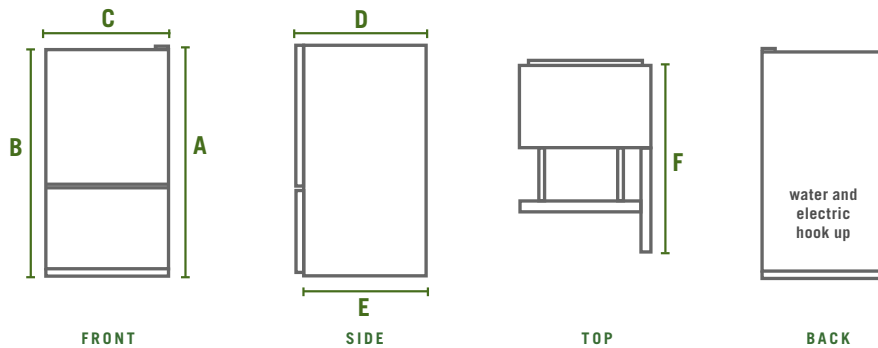

DIMENSIONS ARE SHOWN FOR PLANNING PURPOSES ONLY.

For complete information, see Installation Instructions packed with product.

TOP-FREEZER REFRIGERATORS





FLEXIBLE STORAGE

Plenty of places and options for your storage needs, including crisper bins, a **flip-up storage shelf**, door storage and more.



LONG-LASTING PRODUCE

Humidity-controlled Garden Fresh™ crisper drawers help keep your fruits and veggies fresh for longer.

REFRIGERATE FOR LESS

AMANA® TOP-FREEZER REFRIGERATORS COOL YOUR FOOD MORE EFFICIENTLY, SO YOU CAN SAVE OVER \$185 WHILE STORING YOUR FOOD.* WITH OUR LOWEST-ENERGY CONSUMING REFRIGERATOR EVER, YOU CAN START LOWERING YOUR BILLS NOW.



A FLIP OF THE SWITCH

Easy-to-adjust **Electronic Temperature Control** settings make temperature changes quick and simple.



CUSTOMIZE IT

Reversible doors let you open your refrigerator and freezer door on the side you want and make it easy to adjust to your space.

Note: Not all features included on all models.
*Compared to average energy use of a pre-2003 refrigerator, 12-year life.

MODEL LINEUP

TOP-FREEZER REFRIGERATORS



14.33 CU. FT.
ART104TFD W/B



15.98 CU. FT.
ART106TFD W/B



18.25 CU. FT.
ART308FFD W/B / M



For every Amana® major appliance sold, a tree will be planted to help rebuild global deforested areas.*



*During 2014, for every major appliance it sells in the U.S., Amana® will donate \$0.10 (the cost of each tree planted). Total donation is expected to plant over 2 million trees.

SPECIFICATIONS

BOLD GREEN type indicates a step-up feature

TOP-FREEZER REFRIGERATOR	ART104TFD	ART106TFD	ART308FFD
Capacity (cu. ft.)	14.33	15.98	18.25
Total Shelf Area (sq. ft.)	17.5	18.38	18.39
Reversible Swing Doors	Yes	Yes	Yes
Integrated Handles	Yes	Yes	Yes
Control Lockout	—	—	Yes
Refrigerator Storage			
Refrigerator Capacity (cu. ft.)	10.46	11.95	13.14
Crisper Drawers	1 Full-Width	1 Full-Width	2 Humidity-Controlled Garden Fresh™
Adjustable Shelves	2 Full-Width Wire	2 Full-Width Wire	2 Full-Width Wire
Door Shelves	2 Full-Width, 1 Partial-Width	2 Full-Width, 1 Partial-Width	2 Full-Width, 1 Partial-Width
Gallon Door Storage	—	Yes	Yes
Dairy Center	Yes	Yes	Yes
Flip-Up Storage	—	—	Yes
Freezer Storage			
Freezer Capacity (cu. ft.)	3.87	4.03	5.11
Optional Auto Ice Maker Kit	ECKMF95	ECKMF95	ECKMF95
Shelves	1 Partial-Width Wire	1 Partial-Width Wire	1 Partial-Width Wire
Door Style	Flat	Flat	Flat
Colors	W, B	W, B	W, B, M

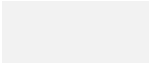
COLORS

	W White Smooth door finish		B Black Smooth door finish		M Monochromatic Stainless Steel Smooth door finish
--	---	--	---	---	---

DIMENSIONS

MODEL	A HEIGHT W/ HINGE	B HEIGHT EXCLUDING HINGE	C CABINET WIDTH	D DEPTH W/ DOOR	E DEPTH EXCLUDING DOOR	F DEPTH W/ DOOR OPEN 90°
ART104TFD	62 7/8"	62 3/8"	28"	30"	27 4/7"	56 3/4"
ART106TFD	65 7/8"	65 3/8"	28"	31 1/4"	27 1/2"	56 3/4"
ART308FFD	65 4/5"	65 2/5"	29 1/2"	31 3/5"	28 1/3"	59 3/4"

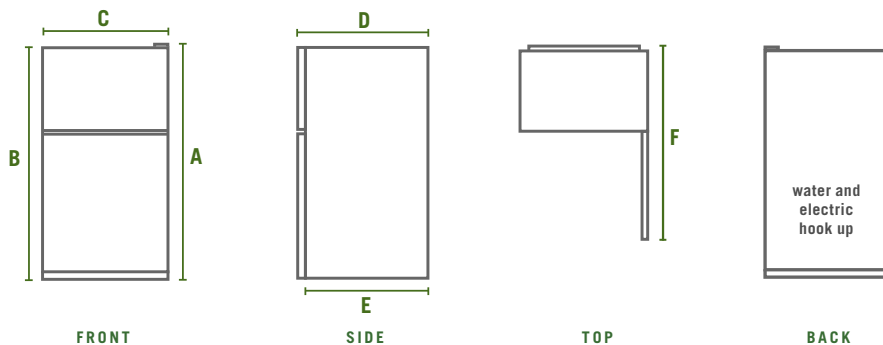

DIMENSIONS ARE SHOWN FOR PLANNING PURPOSES ONLY.

For complete information, see Installation Instructions packed with product.

ACCESSORIES



AFFRESH® STAINLESS STEEL WIPES

#W10355049

Gently cleans fingerprints, smudges and residue to leave a streak-free, polished shine. Contains 35, 7" X 9" use and toss wipes.

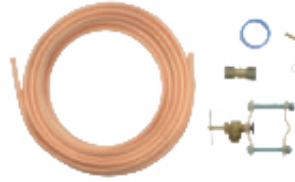

COPPER WATER SUPPLY KIT

#8003RP

Fits most refrigerators and includes (1) 15' copper water supply line, (1) saddle valve, (1) coupling, Teflon® tape and installation instructions.



FRESHFLOW™ PRODUCE PRESERVER STARTER KIT

#P1FB6S1

Extend the freshness of produce by up to four days* with this starter kit that fits in any refrigerator. Replace every 6 months.



MULTI-USE CLEANING BRUSH

#4210463RW

This brush easily removes cobwebs and dust from the coils on your refrigerator to help it continue running at peak performance.

Dimensions:

27 1/2" (H) x 2" (W) x 2" (D)



REPLACEMENT REFRIGERATOR WATER

#Filter1 (#W10295370A)

Replacing your refrigerator water filter every 6 months, or when indicated by the filter system, helps ensure that clean, fresh-tasting drinking water is always available.

*Based on commonly purchased produce.

REFRIGERATOR GLOSSARY



ADJUSTABLE DOOR BINS

Move these bins up or down to fit your food.

CONTROL LOCKOUT

Locks dispenser controls to prevent unintended use of the dispenser.

DAIRY CENTER

Dedicated storage space for dairy food, like butter and yogurt, helps make sure they are easy to find.

DELI DRAWER

Keep track of deli meat and cheese by storing it in this clear drawer.

EASYFREEZER™ PULL-OUT DRAWER

This drawer opens and closes smoothly—even when fully loaded with all your frozen favorites.

GALLON DOOR STORAGE

Holds everything from gallons of milk to 2-liter bottles of soda and containers of juice—whatever quenches your thirst.

GARDEN FRESH™ CRISPER DRAWER

When your garden has grown, this humidity-controlled drawer helps keep fruits and veggies fresh for longer.

REVERSIBLE DOOR SWING

Select refrigerator and freezer doors can be adjusted to open from the left or right.

SPILLSAVER™ GLASS SHELVES

Keep small messes from becoming big problems. These shelves help contain spills, stopping them from dripping onto the shelf below.

TEMP ASSURE™ FRESHNESS CONTROLS

These easy-to-use controls put consistent temperatures right at your fingertips.

NOTES

.....

.....

.....

.....

.....

.....

.....

.....

.....

.....

.....

.....

.....

.....

.....

.....

.....

.....

.....

.....

.....

.....

.....

.....







FREEZERS

STOCK UP AND SAVE BIG

Versatile freezer options and easy-to-use features mean there's always room to buy your favorite frozen foods in bulk. These additional storage units help you freeze food for less, as they use less energy and save you money with efficient cooling.





CHEST

PAGE 72



UPRIGHT

PAGE 74



COMPACT

PAGE 76



CHEST, UPRIGHT AND COMPACT FREEZERS





IDEAL LONG-TERM STORAGE

Deepfreeze® technology cools the freezer down to an ice-cold negative eight degrees to ensure everything stays frozen.



A CONSCIOUS EFFORT TO SAVE

Revolutionary insulation provides low-impact freezing and has a 99.9% lower global warming potential.*

EXTRA ROOM TO CHILL

GO AHEAD AND STOCK UP ON PIZZAS. OUR CHEST, UPRIGHT AND COMPACT FREEZERS GIVE YOU ADDITIONAL FROZEN FOOD STORAGE OPTIONS SO YOU WON'T HAVE TO WORRY ABOUT RUNNING OUT OF ROOM.



NO MORE BUILDUP

Free-O-Frost™ system prevents ice buildup, so you don't have to worry about extra defrost time.



ON A ROLL

Built-in rollers allow you to conveniently install your freezer and easily move it for cleaning, even when full.

Note: Not all features included on all models.

*Based on comparisons of previously used insulation blowing agents, Hydrofluorocarbon (HFC) 245fa with Global Warming Potential of 1020 and Honeywell Solstice Liquid Blowing Agent, a Hydrofluoro-Olefin 1233zd(e) with Global Warming Potential of 1.

MODEL LINEUP
CHEST FREEZERS



14.8 CU. FT.
AZC31T15D W



21.7 CU. FT.
AZC31T22D W



For every Amana® major appliance sold, a tree will be planted to help rebuild global deforested areas.*

*During 2014, for every major appliance it sells in the U.S., Amana® will donate \$0.10 (the cost of each tree planted). Total donation is expected to plant over 2 million trees.



SPECIFICATIONS

BOLD GREEN type indicates a step-up feature

CHEST FREEZER	AZC31T15D	AZC31T22D
Capacity (cu. ft.)	14.8	21.7
Defrost Type	Manual	Manual
Door Swing	Top Swing	Top Swing
Door Style	Flat	Flat
Control Type	Mechanical	Mechanical
Deepfreeze® Technology	Yes	Yes
Baskets	2	3
Colors	W	W

COLOR



DIMENSIONS

MODEL	A HEIGHT	B CABINET WIDTH	C DEPTH
AZC31T15D	33 3/8"	47 3/8"	30 1/4"
AZC31T22D	33 3/8"	66 1/4"	30 1/4"

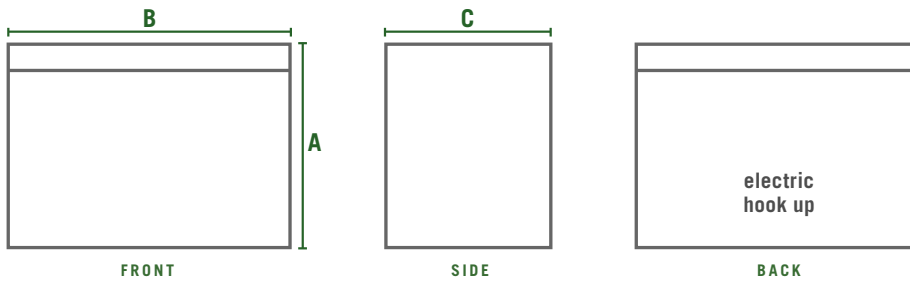

DIMENSIONS ARE SHOWN FOR PLANNING PURPOSES ONLY.

For complete information, see Installation Instructions packed with product.

MODEL LINEUP
UPRIGHT FREEZERS



15.7 CU. FT.
AZF33X16D W



16.6 CU. FT.
AZM12X17D W



17.7 CU. FT.
AZF33X18D W



17.7 CU. FT.
AZB33X18D W



19.6 CU. FT.
AZF33X20D W



19.6 CU. FT.
AZB33X20D W



For every Amana® major appliance sold, a tree will be planted to help rebuild global deforested areas.*

*During 2014, for every major appliance it sells in the U.S., Amana® will donate \$0.10 (the cost of each tree planted). Total donation is expected to plant over 2 million trees.

SPECIFICATIONS

BOLD GREEN type indicates a step-up feature

UPRIGHT FREEZER	AZF33X16D	AZM12X17D	AZF33X18D	AZB33X18D	AZF33X20D	AZB33X20D
Capacity (cu. ft.)	15.7	16.6	17.7	17.7	19.6	19.6
ENERGY STAR® Qualified	—	—	—	Yes	—	Yes
Defrost Type	Frost Free	Manual	Frost Free	Frost Free	Frost Free	Frost Free
Reversible Door	Yes	Yes	Yes	Yes	Yes	Yes
Door Style	Contour	Contour	Contour	Contour	Contour	Contour
Interior Light	Yes	Yes	Yes	Yes	Yes	Yes
Control Type	Electronic	Mechanical	Electronic	Electronic	Electronic	Electronic
Rollers	—	4	4	4	4	4
Deepfreeze® Technology	Yes	Yes	Yes	Yes	Yes	Yes
Free-O-Frost™ System	Yes	—	Yes	Yes	Yes	Yes
Fast Freeze	Yes	—	Yes	Yes	Yes	Yes
Revolutionary Insulation	Yes	Yes	Yes	Yes	Yes	Yes
Shelves	3 Wire	3 Wire	4 Wire	4 Wire	4 Wire	4 Wire
Adjustable Shelving	Yes	—	Yes	Yes	Yes	Yes
Lower Cabinet Storage	Yes	Yes	Yes	Yes	Yes	Yes
Colors	W	W	W	W	W	W

COLOR



DIMENSIONS

MODEL	A HEIGHT W/ HINGE	B HEIGHT EXCLUDING HINGE	C CABINET WIDTH	D DEPTH W/ HANDLE	E DEPTH W/ DOOR OPEN 90°
AZF33X16D	60 3/4"	60 1/4"	30 1/4"	29 1/9"	55 7/8"
AZM12X17D	66 3/4"	66 1/4"	30 1/4"	29 1/9"	55 7/8"
AZF33X18D	66 3/4"	66 1/4"	30 1/4"	29 1/9"	55 7/8"
AZB33X18D	66 3/4"	66 1/4"	30 1/4"	29 1/9"	55 7/8"
AZF33X20D	66 3/4"	66 1/4"	30 1/4"	29 1/9"	55 7/8"
AZB33X20D	66 3/4"	66 1/4"	30 1/4"	29 1/9"	55 7/8"

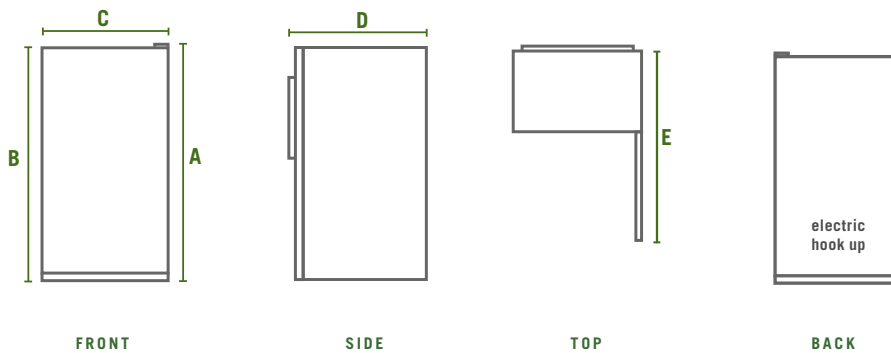

**DIMENSIONS ARE SHOWN
FOR PLANNING PURPOSES ONLY.**

For complete information, see Installation Instructions packed with product.

MODEL LINEUP
COMPACT FREEZERS



5.0 CU. FT.
AQC0501DR W



7.0 CU. FT.
AQC0701DR W



9.0 CU. FT.
AQC0902DR W



For every Amana® major appliance sold, a tree will be planted to help rebuild global deforested areas.*

*During 2014, for every major appliance it sells in the U.S., Amana® will donate \$0.10 (the cost of each tree planted). Total donation is expected to plant over 2 million trees.

SPECIFICATIONS

BOLD GREEN type indicates a step-up feature

COMPACT FREEZER	AQC0501DR	AQC0701DR	AQC0902DR
Capacity (cu. ft.)	5.0	7.0	9.0
STD Energy	Yes	Yes	Yes
Defrost Type	Manual	Manual	Manual
Door Swing	Top Swing	Top Swing	Top Swing
Door Style	Flat	Flat	Flat
Interior Light	—	—	—
Baskets	1 Wire	1 Wire	2 Wire
Power On Indicator Light	Yes	Yes	Yes
Deepfreeze® Technology	Yes	Yes	Yes
Rollers	2	2	4
Leg Levelers	2	2	—
Colors	W	W	W

COLOR

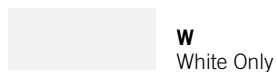

DIMENSIONS

MODEL	A HEIGHT	B CABINET WIDTH	C DEPTH
AQC0501DR	31 ⁷ / ₈ "	30"	22"
AQC0701DR	31 ⁷ / ₈ "	38 ⁴ / ₇ "	23 ² / ₉ "
AQC0902DR	32 ² / ₃ "	43 ⁸ / ₉ "	25 ¹ / ₅ "

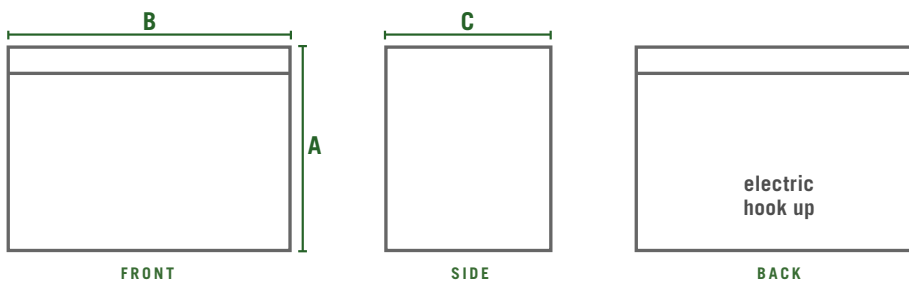

DIMENSIONS ARE SHOWN FOR PLANNING PURPOSES ONLY.

For complete information, see Installation Instructions packed with product.

FREEZER GLOSSARY

BASKETS

Provide a place for small items and keep all your frozen foods organized.

DEEPPFREEZE® TECHNOLOGY

Delivers ideal long-term storage for frozen foods by cooling the freezer down to an ice-cold negative eight degrees, ensuring everything stays frozen.

FAST FREEZE

Freezes large amounts of food fast, running the freezer almost continuously to provide freshly cooled air to drive freezer temps 10 degrees colder than the lowest setting.

FREE-O-FROST™ SYSTEM

Prevents ice buildup, so you don't have to worry about setting aside time to defrost the freezer.

LEG LEVELERS

Help keep your freezer balanced for easy resting, even on uneven floors.

REVOLUTIONARY INSULATION

Provides low-impact freezing and has a 99.9% lower global warming potential,* while helping save energy.

ROLLERS

Up to four rollers use swivels for smooth movement on flat surfaces and allow for easy movement of your freezer when it's fully loaded.





MAKE A PURCHASE. WE'LL PLANT A TREE.

(OVER 3 MILLION IN FACT)

For every step forward, a smaller footprint is left behind.
Amana brand and Trees for the Future have teamed up to make a bigger impact on the world, while making a smaller impact on the environment.

Trees for the Future is a charity that combines agriculture and forestry to create integrated and sustainable land-use systems. Trees and shrubs are planted near crops and livestock, which helps improve soil quality, yield higher crops and contribute to a better standard of living for people in rural communities.

So for every Amana® major appliance sold in 2014, we'll donate a tree.*



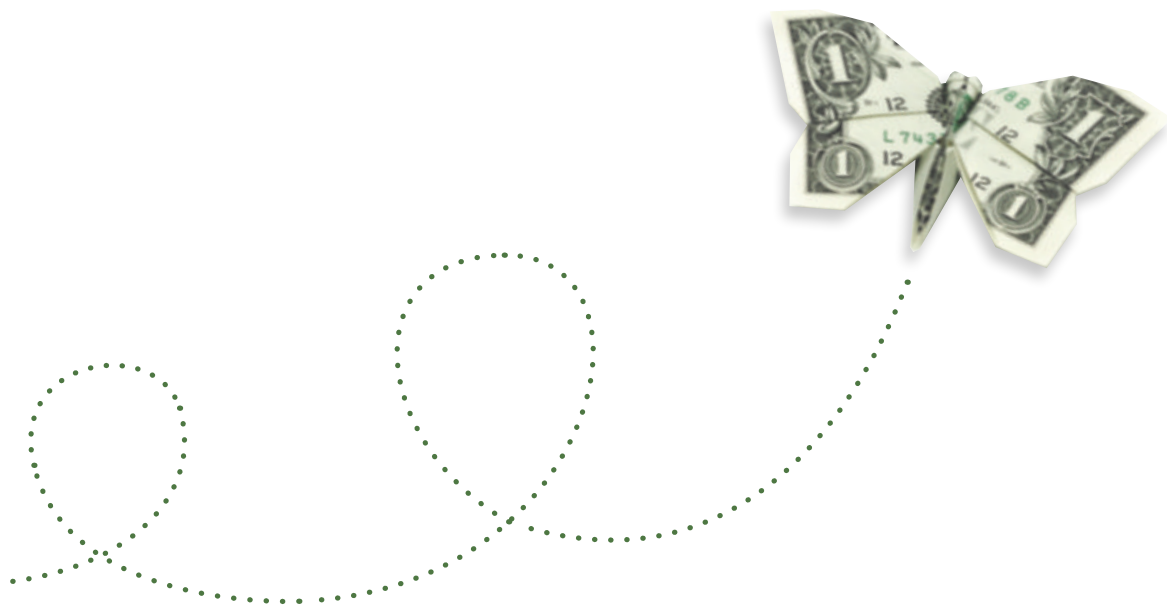

CATALOG 2014

Amana[®]