



FORWARD



Winter 2013
Interactive Catalog

Last updated 2/1/13

INTERACTIVE CATALOG GUIDE

For the best experience, view this interactive PDF in Adobe® Reader® 9 or higher.

Document Navigation

Active links throughout the document are blue and will change the cursor icon from  to 

+ OPEN VIEW

WDF310PAA **W | B | T | D | S**

ENERGY STAR® qualified
Meets CEE Tier 1* standards
In-the-Rack silverware basket
Resource-efficient wash system
Quiet Partner™ I sound package
6" Console with electronic controls
White plastic tall tub

Plus signs indicate interactive elements such as alternate images or video links.

Model number links go to their corresponding dimension charts.

	WHIRLPOOL GOLD®	
MODEL	WDT710PAY	WDF7308
New 2012 model		
Replaces model	GU2275XTV	GU2300X
Place setting capacity	15	15
ENERGY STAR® qualified		
Meets CEE Tier standards*	Tier 1	Tier 1
Tall tub design		
Tub material	Plastic - Slate	Plastic - S
Sound package	Quiet Partner™ II (55 dBA)	Quiet Part (55 dBA)
30-Day Clean & Quiet guarantee†	♦	
DISHWASHER SYSTEM		

Feature links go to their glossary description.









Click on videos indicated by the Video tab to play them. A control panel will appear when you move your mouse over the video while it is playing.

Full Screen Mode

To enter Full Screen Mode, select Full Screen Mode under the View menu (or press Ctrl and L on a PC, Command and L on a Mac)

To exit full screen mode, press Esc

Keyboard Shortcuts

	PC	MAC
	LEFT ARROW	LEFT ARROW
	RIGHT ARROW	RIGHT ARROW
	ALT and LEFT ARROW	COMMAND and LEFT ARROW
	CTRL and -	COMMAND and -
	CTRL and +	COMMAND and +
	CTRL and P	COMMAND and P
	SHIFT and CTRL and F	SHIFT and COMMAND and F

Menu Key

Go back to the last view state (the previous zoom level or the previous page, whichever was changed last)

Go forward one page

Go back one page

Go to the Table of Contents

Shrink the page

Magnify the page

Open the print dialogue (the full catalog will print by default)

Search the document

Open the color reference panel (click the panel to close it)

True innovation takes the complexity out

We make it easy. Whether it's in the kitchen or the laundry room, Whirlpool® appliances will fit seamlessly into your home and your life. We balance the latest technology with effortless features that will exceed your expectations and change the way you think about appliances. Our innovations are advanced to take the complexity out, so you can spend less time with your appliances and more time doing what you love.

Contents

REFRIGERATION

- 10 Side-by-side refrigerators
- 20 French door and classic bottom-freezer refrigerators
- 30 Top-freezer refrigerators
- 44 Upright and chest freezers
- 53 Automatic icemaker
- 54 Accessories
- 56 Glossary
- 58 Specifications

COOKING

- 76 Freestanding ranges
- 96 Wall ovens
- 104 Cooktops
- 118 Microwaves
- 126 Hoods and vents
- 134 Accessories
- 136 Glossary
- 140 Specifications

DISHWASHERS

- 162 Built-in dishwashers
- 170 Compact dishwasher
- 171 Portable dishwasher
- 172 Food disposers
- 174 Trash compactors
- 176 Accessories
- 178 Glossary
- 180 Specifications

LAUNDRY

- 188 High efficiency (HE) front load laundry
- 198 High efficiency (HE) top load laundry
- 208 Traditional top load laundry
- 214 Laundry 1-2-3™ custom laundry options
- 216 Specialty laundry pairs
- 218 Accessories
- 220 Glossary

Video List

REFRIGERATION

- AccuFresh™ dual cooling system
- Full-width temperature controlled pantry
- In-Door-Ice® system
- MicroEdge™ shelves
- Most fresh food capacity available*
- Flexible freezer organization
- Triple Crisper system

COOKING

- AccuBake® temperature management system
- AquaLift® self-clean technology
- FIT system
- Rapid Preheat
- SteamClean option
- TimeSavor™ Plus true convection
- TimeSavor™ Ultra true convection

DISHWASHERS

- AnyWare™ Plus silverware basket
- EZ Adjustable tines
- Sensor cycle
- Top Rack Wash option
- Triple filtration system

LAUNDRY

- FanFresh® option with Dynamic Venting Technology®
- Precision Dispense Ultra
- Quad baffles
- SilentSteel™ dryer drum

*Based on fresh food volume among leading brand french door refrigerators with in the door ice.

Stainless Collection

featuring Stainless Steel kitchen appliances



Make your kitchen the focal point of your home with Whirlpool brand's leading design. Flawless exteriors and alluring finishes will enhance your appliances and create a premium kitchen experience that is sure to inspire.



Ice Collection

featuring White Ice kitchen appliances

Accented with soft cues of metal, this exclusive collection redefines the classic white design. An exciting modern signature is balanced against a beautiful finish to bring appliances to a new level of sophistication.

Ice Collection

featuring Black Ice kitchen appliances



Elevate the design and sophistication of your appliances with the dramatic beauty and refined style of this exclusive collection. By balancing modern cues in metal against a sleek black surface, these enticing models will energize any kitchen.



VIDEO



REFRIGERATION

- 10 Side-by-side refrigerators
- 20 French door and classic bottom-freezer refrigerators
- 30 Top-freezer refrigerators
- 44 Upright and chest freezers
- 53 Automatic icemaker
- 54 Accessories
- 56 Glossary
- 58 Specifications



WRS965CIAH

SIDE-BY-SIDE REFRIGERATORS



Stores more fresh and frozen food

The largest side-by-side refrigerator in the industry* offers a variety of flexible storage solutions to deliver unprecedented fresh food space. The In-Door-Ice® Plus system also helps these models deliver the largest capacity freezer in the industry.**



Offers greater shelf space

Industry-exclusive MicroEdge™ spill-control shelves offer 25% more usable shelf space† and hold up to 75 lbs of food. Not only do they offer wall-to-wall storage, they also manage leaks and help prevent them from spreading.



Cools food quickly

Save energy and cool your food quickly with the Accu-Chill™ temperature management system. This intuitive system senses and adapts using built-in sensors to save more energy and deliver efficient cooling performance, while Adaptive Defrost saves more energy‡ by defrosting only when necessary.



Opens up freezer space

By placing the icemaker and removable ice bin in the door, the In-Door-Ice® Plus system creates 30% more usable space in the freezer.‡ The ice bin also tilts out or can be removed with one hand, to make filling glasses or pitchers with fresh, filtered ice easy.

NOTE: Not all features are available on all models.

*Among freestanding side-by-side refrigerators. **Among freestanding refrigerators. †Compared to Whirlpool® side-by-side models without MicroEdge™ shelves. ‡As compared to Whirlpool® side-by-side refrigerators without Adaptive Defrost. ‡Compared to 26 cu. ft. Whirlpool® side-by-side models with conventional icemakers.

Side-by-Side Refrigerators



ED5KVEXV 25 cu. ft. Q | B | L
ED2KVEXV 22 cu. ft. Q | B | L
 ENERGY STAR® qualified
 Meets CEE Tier 1* standards
 PUR® 6-month ice and water filtration
 Adjustable gallon door bins
 Adaptive Defrost
 SpillGuard™ glass refrigerator shelves

Side-by-Side Refrigerators



ED5FVAXW 25 cu. ft. L
In-Door-Ice® system
 ENERGY STAR® qualified
 Meets CEE Tier 1* standards
 PUR® 6-month ice and water filtration
 Adjustable gallon door bins
 Adaptive Defrost
 SpillGuard™ glass refrigerator shelves



ED5GVEXV 25 cu. ft. D
ED2GVEXV 22 cu. ft. D
 ENERGY STAR® qualified
 Meets CEE Tier 1* standards
 PUR® 6-month ice and water filtration
 Adjustable gallon door bins
 Adaptive Defrost
 SpillGuard™ glass refrigerator shelves



ED5LHAXW 25 cu. ft. Q | B | T | S
In-Door-Ice® system
 ENERGY STAR® qualified
 Meets CEE Tier 1* standards
 PUR® 6-month ice and water filtration
 Adjustable gallon door bins
 Adaptive Defrost
 SpillGuard™ glass refrigerator shelves

*Based on the Consortium for Energy Efficiency qualifying product lists. Visit cee1.org for more information.

Step-up features highlighted by yellow bar



Most Whirlpool® refrigerators are ENERGY STAR® qualified.

*Based on the Consortium for Energy Efficiency qualifying product lists. Visit cee1.org for more information.

Feature descriptions can be found in the [glossary](#) on pages 56–57. Complete product specifications can be found on page 58.

Side-by-Side Refrigerators



ED2KHAXV 22 cu. ft. Q | B | T | L | S

- LCD screen ice and water dispenser
- Freezer pizza shelf
- In-Door-Ice® system
- ENERGY STAR® qualified
- Meets CEE Tier 1* standards
- PUR® 6-month ice and water filtration
- Adjustable gallon door bins
- Adaptive Defrost
- SpillGuard™ glass refrigerator shelves

Side-by-Side Refrigerators



WRS526SIA 26 cu. ft. H | E

- Additional SpillGuard™ glass refrigerator shelf
- White Ice and Black Ice color options
- In-Door-Ice® Plus system
- Accu-Chill™ temperature management system
- FreshFlow™ air filter
- ENERGY STAR® qualified
- Meets CEE Tier 1* standards
- PUR® 6-month ice and water filtration
- Adjustable gallon door bins
- Adaptive Defrost



WSF26C2EX 26 cu. ft. W | B | F | Y

- In-Door-Ice® Plus system
- Accu-Chill™ temperature management system
- FreshFlow™ air filter
- ENERGY STAR® qualified
- Meets CEE Tier 1* standards
- PUR® 6-month ice and water filtration
- Adjustable gallon door bins
- Adaptive Defrost
- SpillGuard™ glass refrigerator shelves



GSF26C4EX 26 cu. ft. W | B | T | F | S | Y

- Whirlpool Gold® model
- MicroEtch™ glass refrigerator shelves
- In-Door-Ice® Plus system
- Accu-Chill™ temperature management system
- FreshFlow™ air filter
- ENERGY STAR® qualified
- Meets CEE Tier 1* standards
- PUR® 6-month ice and water filtration
- Adjustable gallon door bins
- Adaptive Defrost

*Based on the Consortium for Energy Efficiency qualifying product lists. Visit cee1.org for more information.

Step-up features highlighted by yellow bar



Most Whirlpool® refrigerators are ENERGY STAR® qualified.

*Based on the Consortium for Energy Efficiency qualifying product lists. Visit cee1.org for more information.

Feature descriptions can be found in the [glossary](#) on pages 56–57. Complete product specifications can be found on pages 59–60.

Side-by-Side Refrigerators



GSS26C4XX 26 cu. ft. W | B | F | Y

Whirlpool Gold® model

- Multipoint **white LED interior lighting**
- Meets **CEE Tier 3*** standards
- MicroEtch™ glass refrigerator shelves
- In-Door-Ice® Plus system
- Accu-Chill™ temperature management system
- FreshFlow™ air filter
- ENERGY STAR® qualified
- PUR® 6-month ice and water filtration
- Adjustable gallon door bins
- Adaptive Defrost



WRS537SIA 27 cu. ft. W | B | T | F | M

- Tap Touch controls
- Measured Fill
- In-Door-Ice® Plus system
- Accu-Chill™ temperature management system
- White LED interior lighting
- FreshFlow™ air filter
- ENERGY STAR® qualified
- Meets **CEE Tier 3*** standards
- PUR® 6-month ice and water filtration
- Adjustable gallon door bins
- Adaptive Defrost

Side-by-Side Refrigerators



GSS30C6EY 30 cu. ft. W | B | F | Y

Whirlpool Gold® model

- MicroEtch™ glass refrigerator shelves
- Multipoint **white LED interior lighting**
- Additional **Adjustable gallon door bin**
- In-Door-Ice® Plus system
- Accu-Chill™ temperature management system
- Tap Touch controls
- Measured Fill
- FreshFlow™ air filter
- ENERGY STAR® qualified
- Meets **CEE Tier 1*** standards
- PUR® 6-month ice and water filtration
- Adaptive Defrost

*Based on the Consortium for Energy Efficiency qualifying product lists. Visit cee1.org for more information.

Step-up features highlighted by yellow bar



Most Whirlpool® refrigerators are ENERGY STAR® qualified.

*Based on the Consortium for Energy Efficiency qualifying product lists. Visit cee1.org for more information.

Feature descriptions can be found in the [glossary](#) on pages 56–57. Complete product specifications can be found on page 60.

Counter Depth Side-by-Side Refrigerators



GSC25C4EY 25 cu. ft. W | B | Y

- Whirlpool Gold® model
- Counter depth model: 69" height
- MicroEtch™ glass refrigerator shelves
- In-Door-Ice® Plus system
- Accu-Chill™ temperature management system
- Multipoint white LED interior lighting
- FreshFlow™ air filter
- ENERGY STAR® qualified
- Meets CEE Tier 1* standards
- PUR® 6-month ice and water filtration
- Adjustable gallon door bins
- Adaptive Defrost



GSC25C6EY 25 cu. ft. W | B | Y

- Whirlpool Gold® model
- Counter depth model: 72" height
- MicroEtch™ glass refrigerator shelves
- In-Door-Ice® Plus system
- Accu-Chill™ temperature management system
- Multipoint white LED interior lighting
- FreshFlow™ air filter
- ENERGY STAR® qualified
- Meets CEE Tier 1* standards
- PUR® 6-month ice and water filtration
- Adjustable gallon door bins
- Adaptive Defrost

Counter Depth Side-by-Side Refrigerators



WRS965CIA 25 cu. ft. M | H | E

- Whirlpool Gold® model
- Multipoint ramp-up **white LED interior lighting**
- Tap Touch controls**
- Additional **Adjustable gallon door bin**
- White Ice and Black Ice color options
- Counter depth model: 69" height
- MicroEdge™ glass refrigerator shelves
- In-Door-Ice® Plus system
- Accu-Chill™ temperature management system
- FreshFlow™ air filter
- ENERGY STAR® qualified
- Meets CEE Tier 1* standards
- PUR® 6-month ice and water filtration
- Adaptive Defrost

*Based on the Consortium for Energy Efficiency qualifying product lists. Visit cee1.org for more information.

Step-up features highlighted by yellow bar



Most Whirlpool® refrigerators are ENERGY STAR® qualified.

*Based on the Consortium for Energy Efficiency qualifying product lists. Visit cee1.org for more information.

Feature descriptions can be found in the [glossary](#) on pages 56–57. Complete product specifications can be found on page 61.



WRF989SDAH

FRENCH DOOR REFRIGERATORS



Offers greater storage

Store more food with the most fresh food capacity available* and the most door bin space in the industry.** Now you can meet all of your food storage needs and have enough space to hold bulk food purchases and large party platters with our 29 cu. ft. model.



Innovative cooling

The AccuFresh™ dual cooling system helps keep fruits and vegetables fresher and helps keep crystals off ice cream. Food stays tasting great with higher humidity levels and improved food preservation.

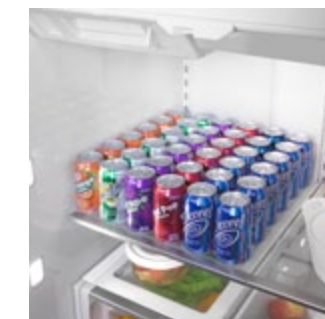

25% more usable shelf space†

Store more items on each shelf with the MicroEdge™ shelves. They not only offer enough strength to hold up to 50 lbs of food, they also help contain leaks. Now your refrigerator will be ready for whatever you bring home from the grocery store.



Opens up refrigerator space

The In-Door-Ice® system creates room for an extra shelf in the refrigerator compartment by storing the ice bin in the door. A removable, clear ice bin lets you fill coolers with ease.

NOTE: Not all features are available on all models.

*Based on fresh food volume among leading brand french door refrigerators with ice in the door. **Based on door bin surface area among leading brand french door refrigerators with ice in the door. †Compared to Whirlpool® french door models without MicroEdge™ shelves.

French Door Refrigerators



WRF560SFY 20 cu. ft. W | B | M

- FreshFlow™ air filter and produce preserver
- ENERGY STAR® qualified
- Meets CEE Tier 2* standards
- Adjustable gallon door bins
- Accu-Chill™ temperature management system
- SpillGuard™ glass refrigerator shelves
- Clear split-width humidity controlled crispers
- White LED interior lighting



WRF560SMY 20 cu. ft. W | B | M

- PUR® 6-month ice filtration**
- Condiment Caddy**
- FreshFlow™ air filter and produce preserver
- ENERGY STAR® qualified
- Meets CEE Tier 2* standards
- Adjustable gallon door bins
- Accu-Chill™ temperature management system
- SpillGuard™ glass refrigerator shelves
- Clear split-width humidity controlled crispers
- White LED interior lighting

French Door Refrigerators



WRF560SEY 20 cu. ft. W | B | M

- PUR® 6-month ice and water filtration**
- Exterior water dispenser
- FreshFlow™ air filter and produce preserver
- ENERGY STAR® qualified
- Meets CEE Tier 2* standards
- Adjustable gallon door bins
- Accu-Chill™ temperature management system
- SpillGuard™ glass refrigerator shelves
- Clear split-width humidity controlled crispers
- White LED interior lighting
- Condiment Caddy



**RATED A
BEST
BUY™**

GX5FHDV 25 cu. ft. Q | B | Y
GX2FHDV 22 cu. ft. Q | B | Y

- Whirlpool Gold® model
- Can caddy**
- ENERGY STAR® qualified
- Meets CEE Tier 1* standards
- Adjustable gallon door bin
- Accu-Chill™ temperature management system
- SpillGuard™ glass refrigerator shelves
- Clear humidity controlled crispers

*Based on the Consortium for Energy Efficiency qualifying product lists. Visit cee1.org for more information.

Step-up features highlighted by yellow bar



Most Whirlpool® refrigerators are ENERGY STAR® qualified.

*Based on the Consortium for Energy Efficiency qualifying product lists. Visit cee1.org for more information. **According to a leading consumer magazine, model GX5FHDV only.

Feature descriptions can be found in the [glossary](#) on pages 56–57. Complete product specifications can be found on page 62.

French Door Refrigerators



RATED A
**BEST
BUY**

GX5FHTXV 25 cu. ft. Q | B | Y

Whirlpool Gold® model

- PUR® 6-month ice and water filtration**
- ENERGY STAR® qualified
- Meets CEE Tier 1** standards
- Adjustable gallon door bin
- Accu-Chill™ temperature management system
- SpillGuard™ glass refrigerator shelves
- Clear humidity controlled crispers



GI6FARXX 26 cu. ft. Q | B | F | Y

Whirlpool Gold® model

- Tap Touch controls**
- Meets CEE Tier 2** standards
- Additional **Adjustable gallon door bin**
- Exterior ice and water dispenser
- ENERGY STAR® qualified
- PUR® 6-month ice and water filtration
- Accu-Chill™ temperature management system
- SpillGuard™ glass refrigerator shelves
- Clear humidity controlled crispers

French Door Refrigerators



GI6FDRXX 26 cu. ft. Q | B | Y

Whirlpool Gold® model

- Ramp-up white LED interior lighting**
- Meets CEE Tier 3** standards
- Tap Touch controls
- ENERGY STAR® qualified
- Adjustable gallon door bins
- PUR® 6-month ice and water filtration
- Accu-Chill™ temperature management system
- SpillGuard™ glass refrigerator shelves
- Clear humidity controlled crispers

*According to a leading consumer magazine. **Based on the Consortium for Energy Efficiency qualifying product lists. Visit cee1.org for more information.

Step-up features highlighted by yellow bar



Most Whirlpool® refrigerators are ENERGY STAR® qualified.

**Based on the Consortium for Energy Efficiency qualifying product lists. Visit cee1.org for more information.

Feature descriptions can be found in the [glossary](#) on pages 56–57. Complete product specifications can be found on pages 62–63.

French Door Refrigerators



WRF989SDA 29 cu. ft. W | B | F | M | H | E

Whirlpool Gold® model

- MicroEdge™ glass refrigerator shelves**
- AccuFresh™ Dual cooling system**
- In-Door-Ice® system**
- Triple Crisper system**
- 11-point, ramp-up white LED interior lighting
- Measured Fill**
- FreshFlow™ air filter and produce preserver**
- White Ice and Black Ice color options
- Tap Touch controls
- ENERGY STAR® qualified
- Meets CEE Tier 2* standards
- Adjustable gallon door bins
- PUR® 6-month ice and water filtration



GZ25FSRX 25 cu. ft. Y

Whirlpool Gold® model

- External refrigerated drawer**
- Ramp-up white LED interior lighting
- Tap Touch controls
- Measured Fill**
- ENERGY STAR® qualified
- Meets CEE Tier 1* standards
- Adjustable gallon door bins
- PUR® 6-month ice and water filtration
- Accu-Chill™ temperature management system
- SpillGuard™ glass refrigerator shelves

Counter Depth French Door Refrigerator



GIOFSAXV 20 cu. ft. B | Y

Whirlpool Gold® model

- ENERGY STAR® qualified
- Meets CEE Tier 1* standards
- Adjustable gallon door bins
- PUR® 6-month ice and water filtration
- Accu-Chill™ temperature management system
- SpillGuard™ glass refrigerator shelves
- Clear humidity controlled crispers

*Based on the Consortium for Energy Efficiency qualifying product lists. Visit cee1.org for more information.

Step-up features highlighted by yellow bar



Most Whirlpool® refrigerators are ENERGY STAR® qualified.

*Based on the Consortium for Energy Efficiency qualifying product lists. Visit cee1.org for more information.

Feature descriptions can be found in the [glossary](#) on pages 56–57. Complete product specifications can be found on pages 63–64.

Bottom-Freezer Refrigerators



EB9SHKXV 19 cu. ft. Q
 ENERGY STAR® qualified
 Meets CEE Tier 1* standards
 Adjustable door bins
 Accu-Chill™ temperature management system
 Glass refrigerator shelves
 Clear humidity controlled crispers
 Reversible side-swing doors

Bottom-Freezer Refrigerators



RATED A
RECOMMENDED BUY**

GB2FHDXW 22 cu. ft. Q | B | S
GB9FHDXW 19 cu. ft. Q | B | S
 Whirlpool Gold® model
 Meets CEE Tier 3* standards
 Freezer drawer
 ENERGY STAR® qualified
 Adjustable door bins
 Accu-Chill™ temperature management system
 Glass refrigerator shelves
 Clear humidity controlled crispers
 Reversible side-swing door

*Based on the Consortium for Energy Efficiency qualifying product lists. Visit cee1.org for more information.

Step-up features
 highlighted by
 yellow bar



Most Whirlpool® refrigerators
 are ENERGY STAR® qualified.

*Based on the Consortium for Energy Efficiency qualifying product lists. Visit cee1.org for more information. **According to a leading consumer magazine, model GB2FHDXW only.

Feature descriptions can be found in the [glossary](#) on pages 56–57. Complete product specifications can be found on page 65.



TOP-FREEZER REFRIGERATORS



Stores more fresh and frozen food

Select models feature storage innovations like the largest capacity pantry drawer available,* the fold-away shelf and Tilt-N-Go door bins. Right Fit™ door bins also perfectly hold gallon-size containers. Now you can easily store groceries where you need them.



Superior cooling performance

The temperature management system senses and adapts to deliver great food preservation. Adaptive Defrost saves up to 12% more energy** by running the defrost cycle only when necessary and by monitoring how often the compressor operates and the doors are open.



Keeps food fresh

The FreshFlow™ air filter reduces common food odors by actively circulating air through our carbon-based filter. The FreshFlow™ produce preserver also extends the freshness of produce up to four days longer† by absorbing ethylene gas that causes produce to over-ripen more quickly.



Puts filtered water in reach

Whirlpool brand offers the industry's only top-freezer refrigerator with an exterior dispenser and electronic controls. Select models offer cold, filtered water without opening the door and easy access to features.

NOTE: Not all features are available on all models.

*Among leading brand top-freezer refrigerators with pantry drawers based on drawer volume. **As compared to previous Whirlpool® top-freezer models with Adaptive Defrost; based on 24-hour interval with refrigerator doors left unopened. †Based on commonly purchased produce.

Flat Door Top-Freezer Refrigerators



W4TXNFW 14 cu. ft. Q | B | T

- Wire refrigerator shelves
- White half-width crispers
- Automatic defrost system
- Optional icemaker

Flat Door Top-Freezer Refrigerators



W5TXEWF 15 cu. ft. Q | B

- ENERGY STAR® qualified**
- Meets CEE Tier 1* standards
- Wire refrigerator shelves
- White full-width crisper
- Automatic defrost system
- Optional icemaker



W6TXNFW 16 cu. ft. Q | T

- Wire refrigerator shelves
- White full-width crisper
- Automatic defrost system
- Optional icemaker



W8TXNFW 18 cu. ft. Q | B | T

- White half-width crispers
- Wire refrigerator shelves
- Automatic defrost system
- Optional icemaker

Step-up features highlighted by yellow bar



Most Whirlpool® refrigerators are ENERGY STAR® qualified.

*Based on the Consortium for Energy Efficiency qualifying product lists. Visit cee1.org for more information.

Feature descriptions can be found in the [glossary](#) on pages 56–57. Complete product specifications can be found on page 66.

Flat Door Top-Freezer Refrigerators



W8TXNMMW 18 cu. ft. Q | B

- Factory-installed icemaker
- Wire refrigerator shelves
- White half-width crispers
- Automatic defrost system



W8TXNGFW 18 cu. ft. Q | B | T

- SpillMizer™ glass refrigerator and freezer shelves
- Clear half-width humidity controlled crispers
- Automatic defrost system
- Optional icemaker

Flat Door Top-Freezer Refrigerators



W8TXNGMW 18 cu. ft. Q | B

- Factory-installed icemaker
- SpillMizer™ glass refrigerator and freezer shelves
- Clear half-width humidity controlled crispers
- Automatic defrost system



W8TXEWFY 18 cu. ft. Q | B

- ENERGY STAR® qualified
- Meets CEE Tier 1* standards
- Wire refrigerator shelves
- Clear half-width crispers
- Automatic defrost system
- Optional icemaker

Step-up features highlighted by yellow bar



Most Whirlpool® refrigerators are ENERGY STAR® qualified.

*Based on the Consortium for Energy Efficiency qualifying product lists. Visit cee1.org for more information.

Feature descriptions can be found in the [glossary](#) on pages 56–57. Complete product specifications can be found on pages 66–67.

Flat Door Top-Freezer Refrigerators



W8TXEGFY 18 cu. ft. Q | B

SpillMizer™ glass refrigerator shelves

- Clear half-width crispers
- ENERGY STAR® qualified
- Meets CEE Tier 1* standards
- Automatic defrost system
- Optional icemaker

Flat Door Top-Freezer Refrigerators



WRT138TFY 18 cu. ft. W | B | S

Clear split-width humidity controlled crispers

- ENERGY STAR® qualified
- Meets CEE Tier 1* standards
- SpillMizer™ glass refrigerator shelves
- Automatic defrost system
- Optional icemaker

*Based on the Consortium for Energy Efficiency qualifying product lists. Visit cee1.org for more information.

Step-up features highlighted by yellow bar



Most Whirlpool® refrigerators are ENERGY STAR® qualified.

*Based on the Consortium for Energy Efficiency qualifying product lists. Visit cee1.org for more information.

Feature descriptions can be found in the [glossary](#) on pages 56–57. Complete product specifications can be found on page 67.

Contoured Door Top-Freezer Refrigerators



WRT11SFA 11 cu. ft. W | B | F

- SpillMizer™ glass refrigerator shelves
- Clear full-width humidity controlled crisper
- Adjustable gallon door bin
- Automatic defrost system
- Optional icemaker



W6RXNGFW 16 cu. ft. Q | B | S

- SpillMizer™ glass refrigerator and freezer shelves
- Clear half-width humidity controlled crispers
- Automatic defrost system
- Optional icemaker

Contoured Door Top-Freezer Refrigerators



W8RXNGMW 18 cu. ft. Q | B | D | S

- Factory-installed icemaker
- SpillMizer™ glass refrigerator and freezer shelves
- Clear half-width humidity controlled crispers
- Automatic defrost system



W8RXEGMW 18 cu. ft. Q | B | D | S

- ENERGY STAR® qualified
- Meets CEE Tier 1[†] standards
- Adjustable gallon door bins
- SpillMizer™ glass refrigerator and freezer shelves
- Clear half-width humidity controlled crispers
- Automatic defrost system
- Factory-installed icemaker

Step-up features highlighted by yellow bar



Most Whirlpool® refrigerators are ENERGY STAR® qualified.

*Based on the Consortium for Energy Efficiency qualifying product lists. Visit cee1.org for more information.

Feature descriptions can be found in the [glossary](#) on pages 56–57. Complete product specifications can be found on page 68.

Contoured Door Top-Freezer Refrigerators



WRT311SFY 21 cu. ft. W | B | T

- Clear split-width humidity controlled crispers
- Adjustable Right Fit™ gallon door bins
- SpillMizer™ glass refrigerator shelves
- Automatic defrost system
- Optional icemaker



WRT351SFY 21 cu. ft. W | B | F | M
WRT359SFY 19 cu. ft. W | B | F | M

- ENERGY STAR® qualified
- Meets CEE Tier 3* standards
- SpillMizer™ glass refrigerator shelves
- Clear split-width humidity controlled crispers
- Adjustable Right Fit™ gallon door bins
- Automatic defrost system
- Optional icemaker

Contoured Door Top-Freezer Refrigerators



WRT571SMY 21 cu. ft. W | B | M

- FreshFlow™ air filter and produce preserver
- Adaptive Defrost
- PUR® 6-month ice filtration
- Factory-installed icemaker
- SpillMizer™ glass refrigerator shelves
- Clear split-width humidity controlled crispers
- ENERGY STAR® qualified
- Meets CEE Tier 3* standards
- Adjustable Right Fit™ gallon door bins

*Based on the Consortium for Energy Efficiency qualifying product lists. Visit cee1.org for more information.

Step-up features highlighted by yellow bar



Most Whirlpool® refrigerators are ENERGY STAR® qualified.

*Based on the Consortium for Energy Efficiency qualifying product lists. Visit cee1.org for more information.

Feature descriptions can be found in the [glossary](#) on pages 56–57. Complete product specifications can be found on pages 68–69.

Contoured Door Top-Freezer Refrigerators



WRT771RWY 21 cu. ft. W | B | M

Whirlpool Gold® model

SpillMizer™ glass refrigerator and freezer shelves

Interior water dispenser

PUR® 6-month ice and water filtration

Clear split-width humidity controlled crispers

FreshFlow™ air filter and produce preserver

ENERGY STAR® qualified

Meets CEE Tier 3* standards

Adaptive Defrost

Adjustable Right Fit™ gallon door bins

Factory-installed icemaker

Contoured Door Top-Freezer Refrigerators



RATED A
RECOMMENDED BUY**

WRT771REY 21 cu. ft. W | B | M

Whirlpool Gold® model

Exterior water dispenser

Fast Cool option

SpillMizer™ glass refrigerator and freezer shelves

Clear split-width humidity controlled crispers

FreshFlow™ air filter and produce preserver

ENERGY STAR® qualified

Meets CEE Tier 1* standards

Adaptive Defrost

Adjustable Right Fit™ gallon door bins

PUR® 6-month ice and water filtration

Factory-installed icemaker

*Based on the Consortium for Energy Efficiency qualifying product lists. Visit cee1.org for more information.

Step-up features highlighted by yellow bar



Most Whirlpool® refrigerators are ENERGY STAR® qualified.

*Based on the Consortium for Energy Efficiency qualifying product lists. Visit cee1.org for more information. **According to a leading consumer magazine.

Feature descriptions can be found in the [glossary](#) on pages 56–57. Complete product specifications can be found on page 69.



FREEZERS



Saves energy

The #1 rated brand for upright freezers* also delivers nearly an entire lineup of ENERGY STAR® qualified models to choose from. Now it's even easier to store extra frozen food while using less energy, which saves money and helps the environment.



Flexible installation

Reversible doors can be installed to open from the right or the left, depending on kitchen style and configuration, for added flexibility.



Offers peace of mind

Don't waste time worrying about whether or not you've left the freezer door open or if the freezer is too warm. An alarm notifies you if the freezer reaches temperatures above freezing.

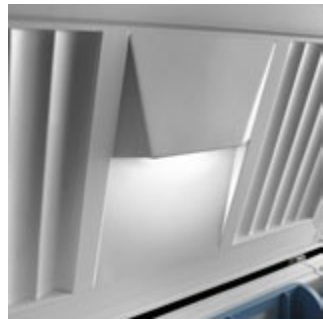

Easy-to-find food

Select Whirlpool brand upright freezers and chest freezers offer 40 watts of illumination, providing the most watts available** so you can easily see what you're looking for, even in the back of the freezer.

NOTE: Not all features are available on all models.

*Based on rating of Whirlpool® model EV161NZT by a leading consumer magazine. **Among leading competitive brand freezers.

Upright Freezers



EV161FZT 16 cu. ft. Q
 ENERGY STAR® qualified
 Reversible, contoured door
 Wire shelves
 Fast Freeze



EV181FZT 18 cu. ft. Q
 Additional wire shelf
 ENERGY STAR® qualified
 Reversible, contoured door
 Fast Freeze

Upright Freezers



EV160NZT 16 cu. ft. Q
 Frost-free defrost
 ENERGY STAR® qualified
 Reversible, contoured door
 Wire shelves
 Fast Freeze



**#1
 RATED***

EV161NZT 16 cu. ft. Q
 Temperature alarm
 ENERGY STAR® qualified
 Reversible, contoured door
 Wire shelves
 Frost-free defrost
 Fast Freeze

Step-up features
 highlighted by
 yellow bar



Most Whirlpool® freezers
 are ENERGY STAR® qualified.

*According to a leading consumer magazine.

Feature descriptions can be found in the [glossary](#) on pages 56–57. Complete product specifications can be found on page 70.

Upright Freezers



EV200NZN 20 cu. ft. Q

- Additional wire shelf
- ENERGY STAR® qualified
- Reversible, contoured door
- Frost-free defrost
- Fast Freeze

Upright Freezers



EV209NBN 20 cu. ft. Q

- Split, reversible, contoured doors
- Lower slide-out bin
- Icemaker ready
- Installation wheels
- Door ajar alarm
- ENERGY STAR® qualified
- Wire shelves
- Frost-free defrost
- Fast Freeze



EV201NZN 20 cu. ft. Q

- Temperature alarm
- Gallon door shelf
- ENERGY STAR® qualified
- Reversible, contoured door
- Wire shelves
- Frost-free defrost
- Fast Freeze



EV250NXT 25 cu. ft. Q

- Temperature alarm
- Additional wire shelf
- Door lock
- Flat door
- Frost-free defrost
- Fast Freeze

Step-up features highlighted by yellow bar



Most Whirlpool® freezers are ENERGY STAR® qualified.

Feature descriptions can be found in the [glossary](#) on pages 56–57. Complete product specifications can be found on page 70.

Chest Freezers



EH151FXT 15 cu. ft. Q
 ENERGY STAR® qualified
 Solid core lid
 Rounded interior corners
 5-sided freezer coils
 Large storage baskets
 Defrost drain with hose adapter
 Integrated door handle design

Chest Freezers



RATED A
RECOMMENDED BUY*

EH225FXT 22 cu. ft. Q
 ENERGY STAR® qualified
 Solid core lid
 Rounded interior corners
 5-sided freezer coils
 Temperature alarm
 Large storage baskets
 Defrost drain with hose adapter
 Integrated door handle design



RATED A
RECOMMENDED BUY*

EH185FXT 18 cu. ft. Q
 Temperature alarm
 Additional large storage basket
 ENERGY STAR® qualified
 Solid core lid
 Rounded interior corners
 5-sided freezer coils
 Defrost drain with hose adapter
 Integrated door handle design

*According to a leading consumer magazine.

Step-up features
 highlighted by
 yellow bar



Most Whirlpool® freezers
 are ENERGY STAR® qualified.

LEARN MORE AT
energystar.gov

*According to a leading consumer magazine.

Feature descriptions can be found in the [glossary](#) on pages 56–57. Complete product specifications can be found on page 71.

SideKicks® Upright Freezer & Refrigerator



EV188NYW (All Freezer) 18 cu. ft. Q | S

- ENERGY STAR® qualified
- Interior light
- Mid-level wire basket
- Lower wire basket
- Frost-free defrost
- Icemaker ready
- Installation wheels

EL88TRRW (All Refrigerator) 18 cu. ft. Q | S

- ENERGY STAR® qualified
- Meets CEE Tier 1* standards
- Interior light
- Gallon door bins
- Installation wheels
- Clear humidity controlled crispers

Automatic Icemaker



G15NDXX Up to 25 lbs Q | B | S

- Whirlpool Gold® model
- Reversible, flat door
- Fast Ice
- Service indicator
- Electronic Clean cycle
- Interior light
- Ice scoop

*Based on the Consortium for Energy Efficiency qualifying product lists. Visit cee1.org for more information.



Most Whirlpool® refrigerators and freezers are ENERGY STAR® qualified.

Feature descriptions can be found in the [glossary](#) on pages 56–57. Complete product specifications can be found on pages 72–73.

Accessories



**PUR® Water Filter
FILTER 1/W10295370**
Models: WSF26C2EX, WRS526SIA, GSF26C4EX, GSS26C4XX, WRS537SIA, GSS30C6EY, GSC25C4EY, GSC25C6EY, WRS965CIA and WRF560SMY, WRF560SEY

**FILTER 2/W10413645A
Model:** WRF989SDA

This filter reduces water contaminants in select Whirlpool® bottom-freezer refrigerators on the right hand side.



**PUR® Push-Button Water Filter
FILTER 3/4396841**

Reduces lead, chlorine taste and odor in your drinking water.* This NSF Certified filter features a base grille location and push-button system for easy replacement.



**PUR® Inside-Turn Water Filter
FILTER 4/UKF8001**

The improved filter design reduces 33% more contaminants,** and its location in the top of the cabinet makes the filter easier to replace, too.



**FreshFlow™ Produce Preserver
Fresh 1/W10346771A**

This replaceable cartridge provides 6 months of ethylene absorption in the crisper drawer, extending the freshness of produce up to four days longer.†



**FreshFlow™ Air Filter
Air 1/W10311524**

This smart air filter is up to 15 times more effective than baking soda in reducing common food odors. Replace filter every 6 months for optimal performance.

Accessories

Satina™ Stainless Look Finish and Stainless Steel Side Panels

- 1 side panel (fits either side on side-by-side and french door refrigerators)
- No tools required—kit includes everything you need for installation
- Satina™ stainless look finish resists fingerprints, accepts magnets and is easy to clean

REFRIGERATOR MODEL	STAINLESS STEEL	SATINA™ STAINLESS LOOK FINISH	DIMENSIONS
23 cu. ft. Counter depth side-by-side refrigerators	4396748	N/A	24.24" W x 68.28" H
25 cu. ft. Counter depth side-by-side refrigerators	4396749	N/A	24.24" W x 71.125" H
25 cu. ft. Contoured and classic side-by-side refrigerators	4396351	8212633	27.68" W x 68.33" H
20 cu. ft. Counter depth french door refrigerators	W10194323	N/A	23.63" W x 68.31" H
25 cu. ft. Freestanding french door refrigerators	W10136753	W10137042	28.63" W x 68.33" H

SideKicks® Upright Freezer and Refrigerator Kits

AVAILABLE ACCESSORY	PART NUMBER
Stainless Steel Trim Kit (18 cu. ft.)	SKT60S
Stainless Steel Finishing Kit (18 cu. ft.)	SKFK60S

Side-by-Side Stainless Steel Top Cap

- No tools required—fits side-by-side refrigerators
- Adds 3" to refrigerator height
- Can be used with Satina™ stainless look finish or Stainless steel side panels

REFRIGERATOR MODEL	PART NUMBER	DIMENSIONS
23 cu. ft. Counter depth side-by-side refrigerators	W10136975	2.62" H x 35.53" W x 27.06" D
25 cu. ft. Counter depth side-by-side refrigerators	W10136975	2.62" H x 35.53" W x 27.06" D
25 cu. ft. Freestanding side-by-side refrigerators	W10136976	2.62" H x 35.53" W x 29.88" D

(Cannot be used with contoured door refrigerators.)

Handle Kits

(For side-by-side models: GSF26C4EX, GSS26C4XX, GSS30C6EY, GSC25C4EY, GSC25C6EY)

Alternative handle styles to match the rest of your Whirlpool® kitchen suite

AVAILABLE COLOR	PART NUMBER
White	W10210942A
Black	W10210943A
Biscuit	W10210944A
Stainless Steel	W10257120A

Optional Icemaker Kits

REFRIGERATOR MODEL	INSTALLATION KIT	UNINSTALL KIT
24" Width refrigerators	24ECKMF	—
Side-by-side and top-freezer refrigerators	ECKMF94	4396928
SideKicks® upright freezer	ECKMF94	4396928
Bottom-freezer refrigerators	IC13B	—
30" Width french door refrigerator	IC14B	—
Top-freezer refrigerators	ECKMFEZ1	—

To acquire pricing information, order Whirlpool® refrigeration accessories and determine delivery time, visit whirlpool.com/accessories or call 1-800-462-3819.

*The contaminants or other substances reduced by this water filter are not necessarily in all users' water. Use only on municipally treated water or other supply known to be microbiologically safe. ** Compared to Whirlpool® FILTER 3 (4396841). †Based on commonly purchased produce.

Glossary

Accu-Chill™ temperature management system

Adds built-in sensors to measure the internal temperature and activate the compressor only when necessary to conserve energy while helping to keep food fresh.

AccuFresh™ dual cooling system

This innovative dual evaporator system is found on select french door refrigerators. It helps keep fruits and vegetables fresher and helps keep crystals off ice cream. It uses the right humidity levels in the refrigerator and freezer compartments for improved food preservation.

ADA compliant

Top-freezer refrigerators with this designation fully comply with federal guidelines for accommodating persons with disabilities.

Adaptive Defrost

Monitors when the compressor is running and defrosts only when necessary, resulting in improved food preservation and energy savings.

Adjustable door storage

Gives you the flexibility to store beverages anywhere in the refrigerator door by moving bins where and when you need them.

Automatic defrost system

Refrigerators with this system include a timer, a limit switch and a heater that melts away frost so you don't have to take everything out of your freezer to melt built-up ice.

Can caddy

Holds and dispenses beverage cans to make accessing your favorite beverages quick and easy.

CEE Tier Standards

Based on the Consortium for Energy Efficiency (CEE) qualifying product lists—with the Tier 3 standard being the most efficient.

Clear convertible compartment

Helps preserve the freshness of meat and vegetables by allowing cool air from the freezer to enter the convertible compartment at the level you select.

Condiment Caddy

Transfers condiments or other items easily from the refrigerator to the table or grill.

Counter depth configuration

Fits virtually flush with the countertop, providing up to 6 inches of additional kitchen space while retaining the features and capacity you expect from a Whirlpool® refrigerator.

Clear humidity controlled crisper

Helps preserve the freshness of your favorite fruits and vegetables with controlled humidity levels in the clear, extra-deep crisper. Select side-by-side refrigerators feature the largest crispers in the industry among leading brands.

Electronic ice and water dispenser

Dispenses filtered water on the outside of the refrigerator.

A control lock feature prevents unintended operation.

Select dispensers include an automatic LED night-light that adjusts brightness as the kitchen goes dark.

ENERGY STAR® qualification

Exceeds government standards by over 20% to help conserve natural resources and save money on utility bills.

Fast Cool option

Quickly lowers the refrigerator's temperature at the push of a button. Select Fast Cool after filling your refrigerator with groceries to quickly cool fresh food.

Fast Freeze

Drops the freezer's temperature as low as it can go in the shortest amount of time. Activate Fast Freeze just before adding large amounts of unfrozen food.

Fast Ice

Drops the freezer temperature in select models for a full 24 hours to increase ice production by over 30%.*

Freezer divider

Easily customizes freezer storage and organizes frozen food using the moveable freezer divider bin.

FreshFlow™ air filter

This smart air filter is up to 15 times more effective than baking soda in reducing common food odors. Replace the filter every 6 months for optimal performance.

FreshFlow™ produce preserver

Extends the freshness of produce by up to four days.** A cartridge absorbs ethylene gas that causes fruits and vegetables, like lettuce and cantaloupe, to over-ripen more quickly. Replace the filter every 6 months for optimal performance.

In-Door-Ice® system

In french door refrigerators, this innovative system moves the ice bin to the door to create room for an extra shelf in the refrigerator compartment. In side-by-side models, moving the ice bin to the door helps the freezer store up to 8 more frozen pizzas.† A removable, clear ice bin lets you fill coolers with ease.

In-Door-Ice® Plus system

By placing the icemaker and removable ice bin in the door, this system creates 30% more usable space in the freezer.†† The ice bin is also easily removed for portable ice any time.

Measured Fill

Allows you to select the exact amount of filtered water—in ounces, cups or liters—that you need. The dispenser will fill the container and automatically shut off when complete.

MicroEtch™/MicroEdge™ spill-control shelf

This industry-exclusive innovation gives you 25% more usable shelf space.‡ Each shelf helps create wall-to-wall storage and makes cleaning inside the refrigerator easier than before.

No-slip door bin mat

Keeps items stored in the door bins in an upright position. The mats are removable for easy cleaning.

Pizza pocket

Easily stores frozen pizzas upright in the french door refrigerator's freezer, without the hassle of trying to fit them on flat freezer shelves.

PUR® water filtration system

Reduces contaminants from household water, giving you chilled, filtered water from your refrigerator for up to 6 months. Our new PUR® water filtration system found on select models can save you up to \$600 a year instead of buying bottled water.‡‡ The improved filter design is more compact, easier to replace and reduces 33% more contaminants.‡‡

Satina™ finish

Resists fingerprints for a smooth, glossy appearance, giving your kitchen a touch of style with everyday practicality. Accepts magnets and requires no special cleaners.

Satina™ Steel finish

Available on select models, the Satina™ Steel finish provides a look that is even closer to true stainless steel. It cleans easily without special products, resists fingerprints and is magnetic.

SideKicks® upright models

Place the refrigerator and freezer models side by side and get up to a combined 36 cu. ft. of storage for all your favorite foods. Both models feature gallon door bins and are ENERGY STAR® qualified.

SpillGuard™ glass shelf

Helps contain spills and simplifies cleanup, preventing liquids from leaking onto shelves below. Some models feature shelves that are adjustable and slide out, providing easy access to items stored in the back of the refrigerator.

SpillMizer™ glass shelf

Helps contain messy leaks and spills for easier cleanup. Shelves are both adjustable and transparent.

Split door styling

This two-door style combines the easy access of an upright freezer with the bulk food capacity of a chest freezer.

Tap Touch controls

This innovative interface featured on select models brings high-tech style to your kitchen. It allows direct access to refrigerator functions, and its sleek appearance enhances the appeal of any space.

Glossary

Triple Crisper system

Increases storage flexibility with two larger crispers with humidity controls and a center, smaller crisper.

Tilt-N-Go specialty bin

Great for condiments or a carton of eggs, this specialty bin holds items securely and can be removed from the refrigerator door and placed on the table or counter.

White LED interior lighting

This lighting system found in select Whirlpool Gold® models casts a more natural light on the contents of your refrigerator so food looks as it should instead of reflecting the blue hues found in other lighting systems.

*Compared to normal ice production, select models only. **Based on commonly purchased produce. †Space advantage in Whirlpool® 25 cu. ft. models compared to same-size Whirlpool® models with conventional icemakers. ††Compared to 26 cu. ft. Whirlpool® side-by-side models with conventional icemakers.

‡Compared to Whirlpool® side-by-side or french door models without MicroEtch™ or MicroEdge™ shelves. ‡‡Based on use of filtered water and average use of two 6-month, 200-gallon water filters versus purchasing the same amount of leading brand bottled water. ‡‡Compared to Whirlpool® FILTER 3 (4396841).

Side-by-Side Refrigerators

SPECIFICATIONS AND DIMENSIONS

MODEL	WHIRLPOOL®			
	ED5KVEXV ED2KVEXV	ED5GVEXV ED2GVEXV	ED5FVAXW	ED5LHAXW
Capacity (cu. ft.)	25 22	25 22	25	25
Handle type	Bow	Short	Short	Short
Color door finish	Textured	Smooth	Smooth	Smooth
Classic flat door styling	-	-	-	-
WHIRLPOOL BRAND INNOVATIONS				
Adaptive Defrost	-	-	-	-
In-Door-Ice® system	-	-	-	-
ICE & WATER FEATURES				
Dual pad ice and water dispenser	-	-	-	-
PUR® 6-month ice and water filtration	-	-	-	-
Water filter cartridge replacement	FILTER 3 (4396841)	FILTER 3 (4396841)	FILTER 3 (4396841)	FILTER 3 (4396841)
Factory-installed icemaker	-	-	-	-
Water filter indicator light	-	-	-	-
Control lock	-	-	-	-
PERFORMANCE FEATURES				
ENERGY STAR® qualified	-	-	-	-
Meets CEE Tier standards*	Tier 1	Tier 1	Tier 1	Tier 1
Temperature controls	Dial	Dial	Backlit slide	Backlit slide
Interior lighting	-	-	-	-
STORAGE FEATURES				
Refrigerator Compartment				
Door bins	3 white adjustable gallon, 1 white fixed two-liter	3 white adjustable gallon, 1 white fixed two-liter	3 clear adjustable gallon	3 clear adjustable gallon, 1 white fixed two-liter
Door shelves	-	-	1 white full-width fixed	-
SpillGuard™ glass shelves	3 adjustable slide-out, 1 fixed	2 adjustable slide-out, 1 fixed	2 adjustable slide-out, 1 fixed	2 adjustable slide-out, 1 fixed
Clear crispener	-	Humidity controlled	Humidity controlled	Humidity controlled
Clear meat compartment	-	-	-	-
Clear convertible compartment	-	-	-	-
Clear snack compartment	-	-	-	-
Clear dairy bin	-	-	-	-
Freezer Compartment				
Door shelves	4 standard, 1 trim	4 standard, 1 trim	3 fixed, 1 trim	3 standard, 1 trim
Shelves	ED5KVEXV: 3 wire, 1 plastic ED2KVEXV: 3 wire	ED5GVEXV: 3 wire, 1 plastic ED2GVEXV: 3 wire	5 wire	4 wire
White plastic pull-out basket	-	-	-	-
DIMENSIONS AND COLORS				
Height including hinges (A)	69 1/4" / 66 1/4"	69 1/4" / 66 1/4"	69 1/4"	69 1/4"
Cabinet width (B)	35 1/2" / 32 1/4"	35 1/2" / 32 1/4"	35 1/2"	35 1/2"
Depth including handles (C)	35 1/4" / 33 1/4"	35 1/4" / 33 1/4"	33 1/4"	33 1/4"
Height excluding hinges	68 3/4" / 65 1/4"	68 3/4" / 65 1/4"	68 3/4"	68 3/4"
Depth excluding handles	31 1/4" / 30 1/4"	31 1/4" / 30 1/4"	30 1/4"	31 1/4"
Depth less door and base grille	29 1/4"	29 1/4"	29 1/4"	29 1/4"
Depth with door open 90°	49 1/4"	49 1/4"	49 1/4"	49 1/4"
Total volume (cu. ft.)	25.3 / 21.7	25.1 / 21.7	25.4	25.4
Refrigerator volume (cu. ft.)	15.2 / 14.4	15.1 / 14.4	15.4	15.4
Freezer volume (cu. ft.)	9.9 / 7.3	10.0 / 7.3	10.0	10.0
Total shelf area (sq. ft.)	24.3 / 21.0	22.9 / 21.0	20.8	20.8
Available colors	Q B L	D	L	Q B T S

Bold type indicates a step-up feature

*Based on the Consortium for Energy Efficiency qualifying product lists. Visit cee1.org for more information.

Side-by-Side Refrigerators

SPECIFICATIONS AND DIMENSIONS

MODEL	WHIRLPOOL®		
	ED2KHAXV	WSF26C2EX	WRS526SIA
New 2012 model			
Capacity (cu. ft.)	22	26	26
Handle type	Short	Metal	Metal
Smooth door finish	-	-	-
Classic flat door styling	-	-	-
Hidden hinges	-	-	-
WHIRLPOOL BRAND INNOVATIONS			
Accu-Chill™ temperature management system	-	-	-
Adaptive Defrost	-	-	-
In-Door-Ice® system	-	-	-
FreshFlow™ air filter	-	Plus	Plus
ICE & WATER FEATURES			
Dual pad ice and water dispenser	LCD	-	-
PUR® 6-month ice and water filtration	-	-	-
Water filter cartridge replacement	FILTER 3 (4396841)	FILTER 1 (W10295370)	FILTER 1 (W10295370)
Factory-installed icemaker	-	-	-
Water filter indicator light	-	-	-
Control lock	-	-	-
LED dispenser night-light	-	-	-
Door alarm	-	-	-
PERFORMANCE FEATURES			
ENERGY STAR® qualified	-	-	-
Meets CEE Tier standards*	Tier 1	Tier 1	Tier 1
Temperature controls	Backlit slide	Exterior electronic	Exterior electronic
Interior lighting	-	-	-
STORAGE FEATURES			
Refrigerator Compartment			
Door bins	3 clear adjustable gallon, 1 white fixed two-liter	3 clear adjustable gallon, 2 clear adjustable two-liter	2 clear adjustable gallon, 2 clear adjustable two-liter
SpillGuard™ glass shelves	2 adjustable slide-out, 1 fixed	2 adjustable slide-out, 1 fixed	3 adjustable slide-out, 1 fixed
Clear humidity controlled crispener	-	-	-
Clear convertible compartment	-	-	-
Clear snack compartment	-	-	-
Clear dairy bin	-	-	-
Freezer Compartment			
Door shelves	3 standard, 1 trim	-	-
Door bins	-	3 clear fixed	3 clear fixed
Shelves	3 wire, 1 pizza shelf	3 glass	3 glass
Pull-out basket	White plastic	Clear plastic	Clear plastic
DIMENSIONS AND COLORS			
Height including hinges (A)	66 1/4"	69 1/4"	69 1/4"
Cabinet width (B)	32 1/4"	35 1/8"	35 1/8"
Depth including handles (C)	33 3/4"	34 1/4"	34 1/4"
Height excluding hinges	65 1/4"	68 3/8"	68 3/8"
Depth excluding handles	30 1/4"	32 1/8"	32 1/8"
Depth less door and base grille	29 1/4"	29 1/4"	29 1/4"
Depth with door open 90°	49 1/4"	50 1/8"	50 1/8"
Total volume (cu. ft.)	21.8	26.4	26.4
Refrigerator volume (cu. ft.)	14.4	16.4	16.4
Freezer volume (cu. ft.)	7.4	9.9	9.9
Total shelf area (sq. ft.)	20.5	22.8	25.1
Available colors	Q B T L S	W B F Y	H E

Bold type indicates a step-up feature

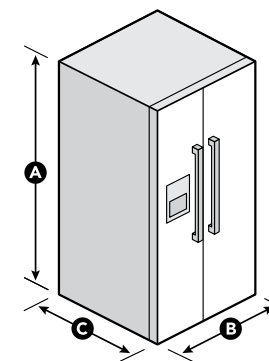

NOTE: Add 1/2" to each side for recessed installation.

ELECTRICAL REQUIREMENTS:

115V, 60Hz. (Subject to local codes.)
Listed by Underwriters' Laboratories, Inc.

DIMENSIONS ARE SHOWN FOR PLANNING PURPOSES ONLY. For complete information, see Installation Instructions packed with product.

*Based on the Consortium for Energy Efficiency qualifying product lists. Visit cee1.org for more information.

Side-by-Side Refrigerators

SPECIFICATIONS AND DIMENSIONS

MODEL	WHIRLPOOL GOLD*		WHIRLPOOL*	WHIRLPOOL GOLD*
	GSF26C4EX	GSS26C4XX	WRS537SIA	GSS30C6EY
New 2012 model				
Capacity (cu. ft.)	26	26	27	30
Metal handles	-	-	-	-
Smooth door finish	-	-	-	-
Door styling	Flat	Contour	Contour	Contour
Hidden hinges	-	-	-	-
Metallic interior trim	-	◆	-	-
WHIRLPOOL BRAND INNOVATIONS				
Accu-Chill™ temperature management system	-	-	-	-
Adaptive Defrost	-	-	-	-
In-Door-Ice® Plus system	-	-	-	-
FreshFlow™ air filter	Air 1 (W10311524)	Air 1 (W10311524)	Air 1 (W10311524)	Air 1 (W10311524)
ICE & WATER FEATURES				
Measured Fill	-	-	◆	-
Dual pad ice and water dispenser	-	-	-	-
PUR® 6-month ice and water filtration	-	-	-	-
Water filter cartridge replacement	FILTER 1 (W10295370)	FILTER 1 (W10295370)	FILTER 1 (W10295370)	FILTER 1 (W10295370)
Factory-installed icemaker	-	-	-	-
Water filter indicator light	-	-	-	-
Control lock	-	-	-	-
LED dispenser night-light	-	-	-	◆
Door alarm	-	-	-	-
PERFORMANCE FEATURES				
ENERGY STAR® qualified	-	-	-	-
Meets CEE Tier standards*	Tier 1	Tier 3	Tier 3	Tier 1
Exterior electronic temperature controls	-	-	Tap Touch	-
White LED interior lighting	-	Multipoint	-	Multipoint
STORAGE FEATURES				
Refrigerator Compartment				
Door bins	2 clear adjustable gallon, 2 clear adjustable two-liter	2 clear adjustable gallon, 2 clear adjustable two-liter	2 clear adjustable gallon, 2 clear adjustable two-liter	4 clear adjustable gallon
Interior shelves	2 adjustable MicroEtch™ glass, 1 fixed SpillGuard™ glass	2 adjustable MicroEtch™ glass, 1 fixed SpillGuard™ glass	3 adjustable slide-out glass, 1 fixed glass	3 adjustable MicroEtch™ glass, 1 fixed SpillGuard™ glass
Clear humidity controlled crisper	-	-	-	-
Clear convertible compartment	-	-	-	-
Clear snack compartment	-	-	-	-
Clear dairy bin	◆	-	-	-
Freezer Compartment				
Clear fixed door bins	3	3	3	3
Glass shelves	3	4	4	4
Clear pull-out bins	-	2	-	2
Clear pull-out plastic basket	-	-	◆	-
DIMENSIONS AND COLORS				
Height including hinges (A)	69 1/4"	69 1/4"	69 1/4"	69 1/4"
Cabinet width (B)	35 7/8"	35 7/8"	35 7/8"	35 7/8"
Depth including handles (C)	34 1/4"	36"	36"	36"
Height excluding hinges	68 3/4"	68 3/4"	68 3/4"	68 3/4"
Depth excluding handles	32 1/4"	33 1/2"	33 1/2"	33 1/2"
Depth less door and base grille	29 1/4"	29 1/4"	29 1/4"	29 1/4"
Depth with door open 90°	50 3/8"	50 3/8"	50 3/8"	50 3/8"
Total volume (cu. ft.)	26.4	26.4	26.5	29.7
Refrigerator volume (cu. ft.)	16.4	16.4	16.6	17.5
Freezer volume (cu. ft.)	9.9	9.9	9.9	12.2
Total shelf area (sq. ft.)	22.7	24.1	27.4	30.4
Available colors	W B T F S Y	W B F Y	W B T F M	W B F Y

Bold type indicates a step-up feature

*Based on the Consortium for Energy Efficiency qualifying product lists. Visit cee1.org for more information.

Counter Depth Side-by-Side Refrigerators

SPECIFICATIONS AND DIMENSIONS

MODEL	WHIRLPOOL GOLD*		
	GSC25C4EY	GSC25C6EY	WRS965CIA
New 2012 model			
Counter depth capacity (cu. ft.)	25	25	25
Metal handles	-	-	-
Smooth door finish	-	-	-
Door styling	Contour	Contour	Contour
Hidden hinges	-	-	-
Metallic interior trim	-	-	-
WHIRLPOOL BRAND INNOVATIONS			
Accu-Chill™ temperature management system	-	-	-
Adaptive Defrost	-	-	-
In-Door-Ice® Plus system	-	-	-
FreshFlow™ air filter	Air 1 (W10311524)	Air 1 (W10311524)	Air 1 (W10311524)
ICE & WATER FEATURES			
Dual pad ice and water dispenser	-	-	-
PUR® 6-month ice and water filtration	-	-	-
Water filter cartridge replacement	FILTER 1 (W10295370)	FILTER 1 (W10295370)	FILTER 1 (W10295370)
Factory-installed icemaker	-	-	-
Water filter indicator light	-	-	-
Control lock	-	-	-
LED dispenser night-light	-	-	-
Door alarm	-	-	-
PERFORMANCE FEATURES			
ENERGY STAR® qualified	-	-	-
Meets CEE Tier standards*	Tier 1	Tier 1	Tier 1
Exterior electronic temperature controls	-	-	Tap Touch
Multipoint white LED interior lighting	-	-	Ramp-up
STORAGE FEATURES			
Refrigerator Compartment			
Door bins	2 clear adjustable gallon, 2 clear adjustable two-liter	2 clear adjustable gallon, 2 clear adjustable two-liter	4 clear adjustable gallon
Interior shelves	3 adjustable MicroEtch™ glass, 1 fixed SpillGuard™ glass	3 adjustable MicroEtch™ glass, 1 fixed SpillGuard™ glass	3 adjustable MicroEdge™ glass, 1 fixed MicroEdge™ glass
Clear humidity controlled crisper	-	-	-
Clear convertible compartment	-	-	-
Clear snack compartment	-	-	-
Clear dairy bin	-	-	-
Hanging beverage rack	-	-	-
Freezer Compartment			
Clear fixed door bins	3	3	3
Glass shelves	4	4	4
Clear pull-out bins	2	2	2
DIMENSIONS AND COLORS			
Height including hinges (A)	69 1/4"	72 1/4"	69 1/4"
Cabinet width (B)	35 7/8"	35 7/8"	35 7/8"
Depth including handles (C)	30 13/16"	30 13/16"	30 13/16"
Height excluding hinges	68 3/4"	71"	68 3/4"
Depth excluding handles	28 1/4"	28 1/4"	28 1/4"
Depth less door and base grille	24 3/8"	24 3/8"	24 3/8"
Depth with door open 90°	45 1/8"	45 1/8"	45 1/8"
Total volume (cu. ft.)	24.5	24.5	24.5
Refrigerator volume (cu. ft.)	14.5	14.3	14.5
Freezer volume (cu. ft.)	10.0	10.2	10.0
Total shelf area (sq. ft.)	23.3	22.5	23.3
Available colors	W B Y	W B Y	M H E

Bold type indicates a step-up feature

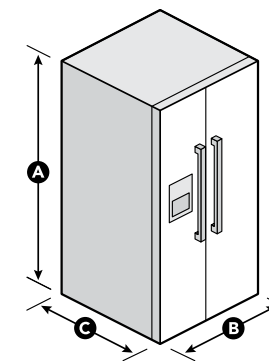

NOTE: Add 1/2" to each side for recessed installation.

ELECTRICAL REQUIREMENTS:

115V, 60Hz. (Subject to local codes.)

Listed by Underwriters' Laboratories, Inc.

DIMENSIONS ARE SHOWN FOR PLANNING PURPOSES ONLY. For complete information, see Installation Instructions packed with product.

*Based on the Consortium for Energy Efficiency qualifying product lists. Visit cee1.org for more information.

French Door Refrigerators

SPECIFICATIONS AND DIMENSIONS

MODEL	WHIRLPOOL®			WHIRLPOOL GOLD®	
	WRF560SFY	WRF560SMY	WRF560SEY	GX5FHDV GX2FHDV	GX5FHTV
New 2012 model	-	-	-	-	-
Capacity (cu. ft.)	20	20	20	25 22	25
Metal handles	•	•	•	•	•
Smooth door finish	•	•	•	•	•
ICE & WATER FEATURES					
Dispenser			Exterior water		Interior water
PUR® 6-month ice and water filtration		Ice only	♦		♦
Water filter cartridge replacement		FILTER 1 (W10295370)	FILTER 1 (W10295370)		FILTER 4 (UKF8001)
Icemaker	Optional (Part No. IC14B)	Factory installed	Factory installed	Factory installed	Factory installed
Dispenser control lock			♦		
PERFORMANCE FEATURES					
ENERGY STAR® qualified	•	•	•	•	•
Meets CEE Tier standards*	Tier 2	Tier 2	Tier 2	Tier 1	Tier 1
Accu-Chill™ temperature management system	•	•	•	•	•
Adaptive Defrost	•	•	•	•	•
Temperature controls	Electronic	Electronic	Electronic	Electronic	Electronic
FreshFlow™ produce preserver	•	•	•	•	•
FreshFlow™ air filter	•	•	•	•	•
Fast Cool option	•	•	•	•	•
White LED interior lighting	•	•	•	•	•
STORAGE FEATURES					
Refrigerator Compartment					
Clear door bins	3 adjustable gallon, 2 fixed gallon, 1 fixed	3 adjustable gallon, 2 fixed gallon	3 adjustable gallon, 2 fixed gallon	1 adjustable gallon, 3 adjustable	1 adjustable gallon, 3 adjustable
No-slip door bin mats				2	2
SpillGuard™ glass shelves	1 full-width slide-out adjustable, 1 full-width fixed	1 full-width slide-out adjustable, 1 full-width fixed	1 full-width slide-out adjustable, 1 full-width fixed	4 half-width adjustable, 1 full-width fixed	3 half-width adjustable slide-out, 1 half-width adjustable, 1 full-width fixed
Adjustable fold-away glass shelf	SpillGuard™	SpillGuard™	SpillGuard™		
Clear humidity controlled crispers	2 split-width	2 split-width	2 split-width	2	2
Full-width pantry	Temperature controlled	Temperature controlled	Temperature controlled	•	Temperature controlled
Clear snack compartment				♦	•
Specialty door bin		Condiment Caddy	Condiment Caddy	Can caddy	Can caddy
Clear dairy bin				♦	•
Freezer Compartment					
Upper slide-out basket	1 white plastic	1 white plastic	1 white plastic	1 wire	1 wire
Lower basket	1 white plastic	1 white plastic	1 white plastic	1 wire	1 wire
Freezer light	•	•	•	•	•
DIMENSIONS AND COLORS					
Height including hinges (A)	68 1/2"	68 1/2"	68 1/2"	70 1/4"	69 5/8"
Cabinet width (B)	29 1/2"	29 1/2"	29 1/2"	35 3/8" / 32 3/8"	35 1/2"
Depth including handles (C)	34 3/4"	34 3/4"	34 3/4"	35 1/8" / 34 1/8"	35 1/2"
Height excluding hinges	67 1/2"	67 1/2"	67 1/2"	68 3/4"	68 3/4"
Depth excluding handles	32 1/8"	32 1/8"	32 1/8"	32 3/16"	32 3/16"
Depth less door and base grille	28 1/2"	28 1/2"	28 1/2"	29 1/8"	29 1/8"
Depth with door open 90°	52 1/2"	52 1/2"	52 1/2"	48"	48"
Total volume (cu. ft.)	19.6	19.6	19.6	24.8 / 21.7	24.8
Refrigerator volume (cu. ft.)	13.3	13.3	13.3	17.3 / 15.4	17.3
Freezer volume (cu. ft.)	6.3	6.3	6.3	7.5 / 6.3	7.5
Total shelf area (sq. ft.)	20.1	20.1	20.1	28.8 / 21.5	28.8
Available colors	W B M	W B M	W B M	Q B Y	Q B Y

Bold type indicates a step-up feature

*Based on the Consortium for Energy Efficiency qualifying product lists. Visit cee1.org for more information.

French Door Refrigerators

SPECIFICATIONS AND DIMENSIONS

MODEL	WHIRLPOOL GOLD®			
	GI6FARXX	GI6FDRXX	WRF989SDA	GZ25FSRXY
New 2012 model				
Capacity (cu. ft.)	26	26	29	25
Metal handles	•	•	•	•
Smooth door finish	•	•	•	•
ICE & WATER FEATURES				
Exterior ice and water dispenser	♦	•	•	•
In-Door-Ice® system			♦	
Measured Fill			♦	
PUR® 6-month ice and water filtration	•	•	•	•
Water filter cartridge replacement	FILTER 4 (UKF8001)	FILTER 4 (UKF8001)	FILTER 2 (W10413645A)	FILTER 4 (UKF8001)
Factory-installed icemaker	•	•	•	•
Fast Ice option	•	•	•	•
Crushed ice	♦	•	•	•
Dispenser control lock	♦	•	•	•
PERFORMANCE FEATURES				
ENERGY STAR® qualified	•	•	•	•
Meets CEE Tier standards*	Tier 2	Tier 3	Tier 2	Tier 1
Cooling system	Accu-Chill™	Accu-Chill™	AccuFresh™ dual	Accu-Chill™
Adaptive Defrost	•	•	•	•
Temperature controls	Tap Touch	Tap Touch	Tap Touch	Tap Touch
FreshFlow™ produce preserver	•	•	♦	•
FreshFlow™ air filter	•	•	♦	•
Fast Cool option	♦	•	•	•
White LED interior lighting		Ramp-up	11-point, ramp-up	Ramp-up
STORAGE FEATURES				
Refrigerator Compartment				
Clear door bins	3 adjustable gallon, 3 fixed	3 adjustable gallon, 3 fixed	3 adjustable gallon, 3 fixed	3 adjustable gallon, 3 fixed
MicroEdge™ glass shelves			3 half-width adjustable, 1 full-width fixed	
SpillGuard™ glass shelves	3 half-width adjustable slide-out, 1 mini adjustable, 1 full-width fixed	3 half-width adjustable slide-out, 1 mini adjustable, 1 full-width fixed		3 half-width adjustable slide-out, 1 half-width adjustable, 1 mini adjustable, 1 full-width fixed
Adjustable fold-away glass shelf			Half-width MicroEdge™ Triple Crisper system	
Clear humidity controlled crispers	2	2		
External refrigerated drawer				♦
Full-width pantry		Temperature controlled	Temperature controlled	
Clear snack compartment				♦
Freezer Compartment				
Upper slide-out baskets	1 wire	1 wire	1 white plastic drawer	1 wire drawer
Lower basket	1 white plastic	1 white plastic	1 white plastic	1 white plastic
Adjustable freezer divider			♦	
Pizza Pocket			♦	
Freezer light	•	•	•	•
DIMENSIONS AND COLORS				
Height including hinges (A)	70 1/4"	70 1/4"	70 1/4"	70 1/4"
Cabinet width (B)	35 3/8"	35 3/8"	35 1/8"	35 3/8"
Depth including handles (C)	35 1/4"	35 1/4"	35 1/8"	35 3/8"
Height excluding hinges	68 3/4"	68 3/4"	68 3/8"	68 3/4"
Depth excluding handles	32 3/4"	32 3/4"	33 3/16"	32 3/4"
Depth less door and base grille	29"	29"	28 3/16"	29"
Depth with door open 90°	48"	48"	48"	48"
Total volume (cu. ft.)	25.5	25.5	28.5	25.0
Refrigerator volume (cu. ft.)	18.9	18.9	20.8	18.4
Freezer volume (cu. ft.)	6.6	6.6	7.7	6.6
Total shelf area (sq. ft.)	26.1	26.1	27.0	25.1
Available colors	Q B F Y	Q B Y	W B F M H E	Y

Bold type indicates a step-up feature

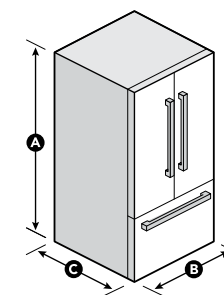

NOTE: Add 1/2" to each side for recessed installation.
ELECTRICAL REQUIREMENTS:
115V, 60Hz. (Subject to local codes.)
Listed by Underwriters' Laboratories, Inc.

*Based on the Consortium for Energy Efficiency qualifying product lists. Visit cee1.org for more information.

DIMENSIONS ARE SHOWN FOR PLANNING PURPOSES ONLY. For complete information, see Installation Instructions packed with product.

Counter Depth French Door Refrigerator

SPECIFICATIONS AND DIMENSIONS

	WHIRLPOOL GOLD®
MODEL	G10FSAXV
Counter depth capacity (cu. ft.)	20
Metal handles	.
Smooth door finish	.
ICE & WATER FEATURES	
Exterior ice and water dispenser	.
PUR® 6-month ice and water filtration	.
Water filter cartridge replacement	FILTER 4 (UKF8001)
Factory-installed icemaker	.
Dispenser control lock	.
PERFORMANCE FEATURES	
ENERGY STAR® qualified	.
Meets CEE Tier standards*	Tier 1
Accu-Chill™ temperature management system	.
Adaptive Defrost	.
Temperature controls	Electronic
Fast Cool option	.
STORAGE FEATURES	
Refrigerator Compartment	
Clear door bins	2 adjustable gallon, 2 adjustable, 2 mini fixed
No-slip door bin mats	4
SpillGuard™ glass shelves	3 half-width adjustable slide-out, 1 mini adjustable, 1 full-width fixed
Clear humidity controlled crispers	2
Full-width pantry	Temperature controlled
Freezer Compartment	
Upper slide-out baskets	2 white plastic
Lower basket	1 white plastic
Freezer light	.
DIMENSIONS AND COLORS	
Height including hinges (A)	70 1/4"
Cabinet width (B)	35 1/8"
Depth including handles (C)	30 1/8"
Height excluding hinges	68 1/8"
Depth excluding handles	27 1/8"
Depth less door and base grille	24"
Depth with door open 90°	43"
Total volume (cu. ft.)	19.8
Refrigerator volume (cu. ft.)	14.9
Freezer volume (cu. ft.)	5.0
Total shelf area (sq. ft.)	20.9
Available colors	B Y

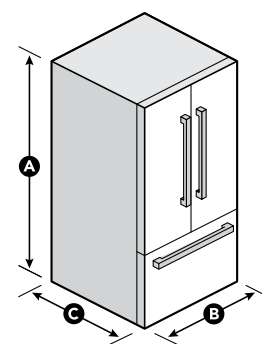

NOTE: Add 1/2" to each side for recessed installation.
ELECTRICAL REQUIREMENTS:
 115V, 60Hz. (Subject to local codes.)
 Listed by Underwriters' Laboratories, Inc.

*Based on the Consortium for Energy Efficiency qualifying product lists. Visit cee1.org for more information.

Bottom-Freezer Refrigerators

SPECIFICATIONS AND DIMENSIONS

	WHIRLPOOL®	WHIRLPOOL GOLD®
MODEL	EB9SHKXV	GB2FHDXW GB9FHDXW
Capacity (cu. ft.)	19	22 19
Refrigerator door style	Side-swing	Side-swing
Freezer door style	Side-swing	Drawer
Handle type	Plastic	Metal
Smooth door finish	.	.
Reversible doors	2	1
ICE & WATER FEATURES		
Factory-installed icemaker	.	.
PERFORMANCE FEATURES		
ENERGY STAR® qualified	.	.
Meets CEE Tier standards*	Tier 1	Tier 3
Accu-Chill™ temperature management system	.	.
Adaptive Defrost	.	♦
Automatic defrost system	.	.
Electronic temperature controls	.	.
STORAGE FEATURES		
Refrigerator Compartment		
Door bins	5 white half-width adjustable, 1 white full-width fixed	3 clear half-width adjustable, 1 white full-width fixed
Glass shelves	2 full-width adjustable, 1 full-width fixed	3 half-width adjustable slide-out, 1 half-width adjustable, 1 full-width fixed
Clear humidity controlled crispers	2	2
Clear dairy bin	.	♦
Clear snack compartment	.	♦
Freezer Compartment		
Door bin	1 fixed	.
Wire shelf	.	.
Upper slide-out wire basket	.	♦
Lower wire basket	.	.
Freezer light	.	.
DIMENSIONS AND COLORS		
Height including hinges (A)	66 5/8"	69 1/8" / 66 5/8"
Cabinet width (B)	29 1/8"	32 1/8" / 29 1/8"
Depth including handles (C)	33 1/8"	33 1/8"
Height excluding hinges	65 1/2"	65 1/2"
Depth excluding handles	30 1/4"	30 1/4"
Depth less door and base grille	28 1/4"	28 1/4"
Depth with door open 90°	59"	62" / 59"
Total volume (cu. ft.)	18.5	21.9 / 18.5
Refrigerator volume (cu. ft.)	12.9	15.6 / 12.9
Freezer volume (cu. ft.)	5.6	6.3 / 5.6
Total shelf area (sq. ft.)	20.0	23.5 / 20.0
Available colors	Q	Q B S

Bold type indicates a step-up feature

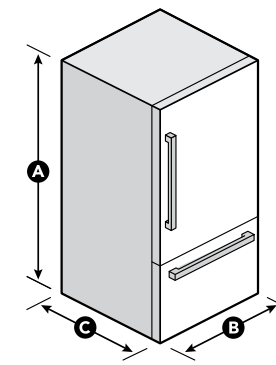

NOTE: Add 1/2" to each side for recessed installation.
ELECTRICAL REQUIREMENTS:
 115V, 60Hz. (Subject to local codes.)
 Listed by Underwriters' Laboratories, Inc.

*Based on the Consortium for Energy Efficiency qualifying product lists. Visit cee1.org for more information.

DIMENSIONS ARE SHOWN FOR PLANNING PURPOSES ONLY. For complete information, see installation instructions packed with product.

Flat Door Top-Freezer Refrigerators

SPECIFICATIONS AND DIMENSIONS

MODEL	WHIRLPOOL®					
	W4TXNWF	W6TXNWF	W5TXEWF	W8TXNWF	W8TXNMF	W8TXNGF
Capacity (cu. ft.)	14	16	15	18	18	18
Flat door style	•	•	•	•	•	•
Short handle	•	•	•	•	•	•
Textured door finish	•	•	•	•	•	•
ADA compliant*	•	•	•	•	•	•
ICE & WATER FEATURES						
Icemaker	Optional (Part no. ECKMF94)	Optional (Part no. ECKMF94)	Optional (Part no. ECKMF94)	Optional (Part no. ECKMF94)	Factory-installed	Optional (Part no. ECKMF94)
PERFORMANCE FEATURES						
ENERGY STAR® qualified			♦			
Meets CEE Tier standards**			Tier 1			
Automatic defrost system	•	•	•	•	•	•
Up-front temperature controls	•	•	•	•	•	•
STORAGE FEATURES						
Refrigerator Compartment						
Fixed door shelves	2 full-width, 1 partial-width	2 full-width, 1 partial-width	2 full-width, 1 partial-width	2 full-width, 1 partial-width	2 full-width, 1 partial-width	2 full-width, 1 partial-width
Clear dairy bin	•	•	•	•	•	•
Interior shelves	2 full-width adjustable wire, 1 full-width fixed clear plastic	2 full-width adjustable wire, 1 full-width fixed white plastic	2 full-width adjustable wire, 1 full-width fixed white plastic	2 full-width adjustable wire, 1 full-width fixed clear plastic	2 full-width adjustable wire, 1 full-width fixed clear plastic	2 full-width adjustable SpillMizer™ glass, 1 full-width fixed SpillMizer™ glass
Crispers	2 white half-width	1 white full-width	1 white full-width	2 white half-width	2 white half-width	2 clear half-width humidity controlled Sliding
Clear snack compartment						
Freezer Compartment						
Door shelves	2 full-width	2 full-width	2 full-width	2 full-width	2 full-width	2 full-width
Interior shelf	1 full-width adjustable wire	1 half-width adjustable wire	1 half-width adjustable wire	1 half-width adjustable wire	1 half-width adjustable wire	1 full-width adjustable SpillMizer™ glass
DIMENSIONS AND COLORS						
Height including hinges (A)	62 1/2"	65 1/2"	62 1/2"	67 1/8"	67 1/8"	67 1/8"
Cabinet width (B)	28"	28"	28"	28"	28"	28"
Depth including handles (C)	31 1/2"	32 1/2"	32 1/2"	32 1/2"	32 1/2"	32 1/2"
Height excluding hinges	62 1/2"	65 1/2"	62 1/2"	67 1/8"	67 1/8"	67 1/8"
Depth excluding handles	29 3/4"	30 3/4"	31 1/4"	30 3/4"	30 3/4"	30 3/4"
Depth less door and base grille	27 1/2"	27 1/2"	27 1/2"	27 3/4"	27 3/4"	27 3/4"
Depth with door open 90°	57"	57"	57"	57"	57"	57"
Total volume (cu. ft.)	14.4	15.9	14.6	17.6	17.6	17.6
Refrigerator volume (cu. ft.)	10.6	12.0	10.8	13.5	13.5	13.5
Freezer volume (cu. ft.)	3.8	3.9	3.8	4.1	4.1	4.1
Total shelf area (sq. ft.)	17.1	18.5	16.5	19.1	19.1	19.1
Available colors	Q B T	Q T	Q B	Q B T	Q B	Q B T

Bold type indicates a step-up feature

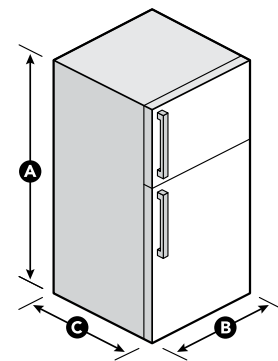

NOTE: Add 1/2" to each side for recessed installation.
ELECTRICAL REQUIREMENTS:
115V, 60Hz. (Subject to local codes.)
Listed by Underwriters' Laboratories, Inc.

*Model meets applicable ADA requirements and must be installed in compliance with the current ADA Standards.
**Based on the Consortium for Energy Efficiency qualifying product lists. Visit ceef.org for more information.

Flat Door Top-Freezer Refrigerators

SPECIFICATIONS AND DIMENSIONS

MODEL	WHIRLPOOL®			
	W8TXNGMW	W8TXEWFY	W8TXEGFY	WRT138TFY
Capacity (cu. ft.)	18	18	18	18
Flat door style	•	•	•	•
Short handle	•	•	•	•
Textured door finish	•	•	•	•
Door Reversal kit available				W10395148
ADA compliant*				♦
ICE & WATER FEATURES				
Icemaker	Factory-installed	Optional (Part no. ECKMF94)	Optional (Part no. ECKMF94)	Optional (Part no. ECKMF94)
PERFORMANCE FEATURES				
ENERGY STAR® qualified		♦	•	•
Meets CEE Tier standards**		Tier 1	Tier 1	Tier 1
Automatic defrost system	•	•	•	•
Up-front temperature controls	•	•	•	•
STORAGE FEATURES				
Refrigerator Compartment				
Fixed door shelves	2 full-width, 1 partial-width	2 full-width, 1 partial-width	2 full-width, 1 partial-width	2 full-width, 2 partial-width
Interior shelves	2 full-width adjustable SpillMizer™ glass, 1 full-width fixed SpillMizer™ glass	2 full-width adjustable wire, 1 full-width fixed clear plastic	2 full-width adjustable SpillMizer™ glass, 1 full-width fixed SpillMizer™ glass	2 full-width adjustable SpillMizer™ glass, 1 full-width fixed SpillMizer™ glass
Clear crispers	2 half-width humidity controlled	2 half-width	2 half-width	2 split-width humidity controlled
Pantry				Partial-width
Clear snack compartment	Sliding			
Clear dairy bin	•	•	•	•
Freezer Compartment				
Door shelves	2 full-width	2 full-width	2 full-width	2 full-width
Interior shelf	1 full-width adjustable SpillMizer™ glass	1 full-width adjustable wire	1 full-width adjustable wire	1 full-width removable wire
DIMENSIONS AND COLORS				
Height including hinges (A)	67 1/8"	67 1/8"	67 1/8"	66 1/4"
Cabinet width (B)	28"	28"	28"	29 1/2"
Depth including handles (C)	32 1/8"	32 1/8"	32 1/8"	32 1/8"
Height excluding hinges	67 1/8"	67 1/8"	67 1/8"	65 1/2"
Depth excluding handles	30 3/4"	30 3/4"	30 3/4"	30 3/4"
Depth less door and base grille	27 3/4"	27 3/4"	27 3/4"	28 1/2"
Depth with door open 90°	57"	57"	57"	59 1/4"
Total volume (cu. ft.)	17.6	17.6	17.6	18.5
Refrigerator volume (cu. ft.)	13.5	13.5	13.5	13.1
Freezer volume (cu. ft.)	4.1	4.1	4.1	5.3
Total shelf area (sq. ft.)	19.1	19.1	19.1	15.7
Available colors	Q B	Q B	Q B	W B S

Bold type indicates a step-up feature

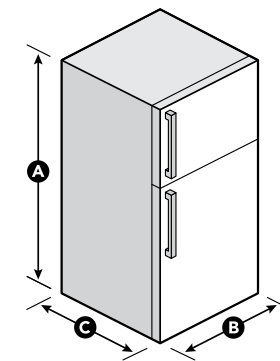

NOTE: Add 1/2" to each side for recessed installation.
ELECTRICAL REQUIREMENTS:
115V, 60Hz. (Subject to local codes.)
Listed by Underwriters' Laboratories, Inc.

*Model meets applicable ADA requirements and must be installed in compliance with the current ADA Standards.
**Based on the Consortium for Energy Efficiency qualifying product lists. Visit ceef.org for more information.

DIMENSIONS ARE SHOWN FOR PLANNING PURPOSES ONLY.
For complete information, see Installation Instructions packed with product.

Contoured Door Top-Freezer Refrigerators

SPECIFICATIONS AND DIMENSIONS

MODEL	WHIRLPOOL®				
	WRT111SFA	W6RXNGFW	W8RXNGMW	W8RXEGMW	WRT311SFY
New 2012 model	-	-	-	-	-
Capacity (cu. ft.)	11	16	18	18	21
Contoured door style	-	-	-	-	-
Handle type	Integrated	Integrated	Integrated	Integrated	Contemporary
Door finish	Smooth	Smooth	Smooth	Smooth	Smooth
Hidden hinges	-	-	-	-	♦
Door Reversal kit available	-	-	-	-	W10395148
ADA compliant*	-	-	-	-	♦
ICE & WATER FEATURES					
Icemaker	Optional (Part no. 24ECKMF)	Optional (Part no. ECKMF94)	Factory-installed	Factory-installed	Optional (Part no. ECKMF94)
PERFORMANCE FEATURES					
ENERGY STAR® qualified	-	-	-	♦	-
Meets CEE Tier standards**	-	-	-	Tier 1	-
Temperature control system	Up-front	Up-front	Up-front	Up-front	Up-front
Automatic defrost system	-	-	-	-	-
Interior lighting	-	-	-	-	-
STORAGE FEATURES					
Refrigerator Compartment	1 full-width fixed, 1 full-width adjustable gallon, 1 full-width adjustable		2 half-width adjustable gallon, 1 half-width adjustable, 1 full-width fixed gallon		2 Right Fit™ adjustable gallon, 1 adjustable gallon
Fixed door shelves	-	2 full-width, 1 partial-width	2 full-width, 1 partial-width	1 full-width	1 full-width
SpillMizer™ glass shelves	2 full-width adjustable glass, 1 full-width fixed glass	2 full-width adjustable, 1 full-width fixed	2 full-width adjustable, 1 full-width fixed	2 full-width adjustable, 1 full-width fixed	2 full-width adjustable, 1 full-width fixed
Clear crispers	1 full-width humidity controlled	2 half-width humidity controlled	2 half-width humidity controlled	2 half-width humidity controlled	2 split-width humidity controlled
Partial-width pantry	-	-	-	-	♦
Clear snack compartment	Sliding		Sliding	Sliding	-
Can caddy	-	-	-	-	♦
Clear dairy bin	-	♦	-	-	-
Freezer Compartment	-				
Door shelves	2 full-width	2 full-width	2 full-width	2 full-width	2 full-width
Interior shelf	1 half-width fixed wire	1 full-width adjustable SpillMizer™ glass	1 full-width removable SpillMizer™ glass	1 full-width removable SpillMizer™ glass	1 full-width removable wire
DIMENSIONS AND COLORS					
Overall height (A)	61 1/2"	66"	68"	68"	66 1/2"
Cabinet width (B)	24"	28"	28"	28"	32 1/2"
Depth including handles (C)	28 1/4"	30 1/4"	30 1/4"	30 1/4"	34"
Cabinet height	60 1/4"	65 1/4"	67 1/4"	67 1/4"	65 1/2"
Depth excluding handles	28 1/4"	30 1/4"	30 1/4"	30 1/4"	32 1/2"
Depth less door and base grille	21 1/2"	26 1/4"	27 1/4"	27 1/4"	28 1/2"
Depth with door open 90°	48 1/2"	55 1/4"	54 1/4"	54 1/4"	62 1/4"
Total volume (cu. ft.)	10.7	15.9	17.5	17.5	20.6
Refrigerator volume (cu. ft.)	7.8	12.0	13.5	13.5	15.0
Freezer volume (cu. ft.)	2.9	3.9	4.1	4.1	6.1
Total shelf area (sq. ft.)	11.9	18.5	18.7	18.7	21.0
Available colors	W B F	Q B S	Q B D S	Q B D S	W B T

Bold type indicates a step-up feature

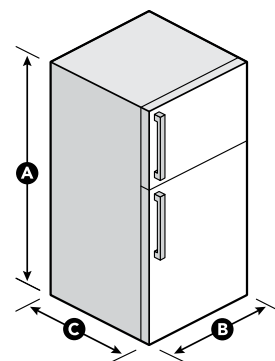

NOTE: Add 1/2" to each side for recessed installation.

ELECTRICAL REQUIREMENTS:

115V, 60Hz. (Subject to local codes.)
Listed by Underwriters' Laboratories, Inc.

*Model meets applicable ADA requirements and must be installed in compliance with the current ADA Standards.
**Based on the Consortium for Energy Efficiency qualifying product lists. Visit ceef.org for more information.

Contoured Door Top-Freezer Refrigerators

SPECIFICATIONS AND DIMENSIONS

MODEL	WHIRLPOOL®		WHIRLPOOL GOLD®	
	WRT351SFY WRT359SFY	WRT571SMY	WRT771RWY	WRT771REY
Capacity (cu. ft.)	21 19	21	21	21
Contoured door style	-	-	-	-
Handle type	Contemporary	Contemporary	Embedded	Embedded
Smooth door finish	-	-	-	-
Hidden hinges	-	-	-	-
Door Reversal kit available	W10395148	W10395148	-	-
ADA compliant*	-	-	-	-
ICE & WATER FEATURES				
Exterior water dispenser	-	-	-	♦
Interior water dispenser	-	-	♦	-
PUR® 6-month filtration	-	♦	-	-
Filter cartridge replacement	-	FILTER 1 (W10295370)	FILTER 1 (W10295370)	FILTER 1 (W10295370)
Icemaker	Optional (Part no. ECKMF94)	Factory-installed with clear ice bucket	Factory-installed with clear ice bucket	Factory-installed with clear ice bucket
Filter indicator light	-	♦	-	-
PERFORMANCE FEATURES				
ENERGY STAR® qualified	♦	-	-	-
Meets CEE Tier standards**	Tier 3	Tier 3	Tier 3	Tier 1
Defrost system	Automatic	Adaptive Defrost	Adaptive Defrost	Adaptive Defrost
Temperature controls	Up-front	Up-front electronic	Up-front electronic	Exterior electronic
FreshFlow™ produce preserver	-	Fresh 1 (W10346771A)	Fresh 1 (W10346771A)	Fresh 1 (W10346771A)
FreshFlow™ air filter	-	Air 1 (W10311524)	Air 1 (W10311524)	Air 1 (W10311524)
Fast Cool option	-	-	-	♦
Interior lighting	-	-	-	-
STORAGE FEATURES				
Refrigerator Compartment	-			
Clear adjustable door bins	2 Right Fit™ gallon, 1 gallon	2 Right Fit™ gallon, 1 gallon	2 Right Fit™ gallon, 1 gallon	2 Right Fit™ gallon, 1 gallon
Specialty door bin	Can caddy	Tilt-N-Go	Tilt-N-Go	Tilt-N-Go
Fixed door shelves	1 full-width	1 full-width	1 full-width	1 full-width
SpillMizer™ glass shelves	2 full-width adjustable, 1 full-width fixed	1 full-width adjustable, 1 full-width fixed	1 full-width adjustable, 1 full-width fixed	1 full-width adjustable, 1 full-width fixed
Adjustable fold-away glass shelf	-	♦	-	-
Clear humidity controlled crispers	2 split-width	2 split-width	2 split-width	2 split-width
Full-width pantry	♦	-	-	-
Clear dairy bin	-	-	-	-
Freezer Compartment	-			
Door shelves	2 full-width	2 full-width	2 full-width	2 full-width
Interior shelf	1 full-width removable wire	1 full-width removable wire	1 full-width removable SpillMizer™ glass	1 full-width removable SpillMizer™ glass
Freezer light	-	-	♦	-
DIMENSIONS AND COLORS				
Overall height (A)	66 1/4"	66 1/4"	66 1/4"	66 1/4"
Cabinet width (B)	32 1/2" / 29 1/2"	32 1/2"	32 1/2"	32 1/2"
Depth including handles (C)	33 1/4"	34"	34"	32 1/4"
Cabinet height	65 1/2"	65 1/2"	65 1/2"	65 1/2"
Depth excluding handles	32 1/2" / 32 1/4"	32 1/2"	34"	32 1/4"
Depth less door and base grille	28 1/2"	28 1/2"	28 1/2"	28 1/2"
Depth with door open 90°	62 1/4" / 59 1/4"	62 1/4"	62 1/4"	62 1/4"
Total volume (cu. ft.)	21.1 / 18.9	21.1	21.1	21.1
Refrigerator volume (cu. ft.)	15.0 / 13.6	15.0	15.0	15.0
Freezer volume (cu. ft.)	6.1 / 5.3	6.1	6.1	6.1
Total shelf area (sq. ft.)	20.2 / 18.0	20.2	20.2	20.2
Available colors	W B F M	W B M	W B M	W B M

Bold type indicates a step-up feature

DIMENSIONS ARE SHOWN FOR PLANNING PURPOSES ONLY.
For complete information, see Installation Instructions packed with product.

*Model meets applicable ADA requirements and must be installed in compliance with the current ADA Standards.
**Based on the Consortium for Energy Efficiency qualifying product lists. Visit ceef.org for more information.

Upright Freezers

SPECIFICATIONS AND DIMENSIONS

MODEL	WHIRLPOOL®							
	EV161FZT	EV181FZT	EV160NZT	EV161NZT	EV200NZT	EV201NZT	EV209NBT	EV250NXT
New 2012 model								
Capacity (cu. ft.)	16	18	16	16	20	20	20	25
Door style	Contoured	Contoured	Contoured	Contoured	Contoured	Contoured	Split, contoured	Flat
Door finish	Smooth	Smooth	Textured	Smooth	Textured	Smooth	Smooth	Textured
Integrated metal handles							♦	
Reversible door	•	•	•	•	•	•	•	•
PERFORMANCE FEATURES								
ENERGY STAR® qualified	•	•	•	•	•	•	•	•
Frost-free defrost			♦					
Icemaker ready							ECKMF94	
Fast Freeze	•	•	•	•	•	•	•	•
Temperature alarm				♦		♦		♦
Door ajar alarm							♦	
Door lock								♦
Interior light	•	•	•	•	•	•	•	•
Installation wheels							♦	
STORAGE FEATURES								
Door storage	5 shelves	6 shelves	5 shelves	5 shelves	6 shelves	6 bins, 1 gallon shelf	4 bins, 1 shelf	6 shelves
Mid-level storage						1 wire basket	1 wire basket	1 wire basket
Lower storage	1 wire basket	1 wire basket	1 wire gate	1 wire basket	1 wire basket	1 wire basket	1 slide-out bin	1 wire basket
Wire shelves	3 fixed	4 fixed	3 removable	3 removable	4 adjustable	4 adjustable	3 adjustable	4 removable
DIMENSIONS AND COLORS								
Height including hinges (A)	61¼"	67¼"	61¼"	61¼"	67¼"	67¼"	67¼"	68"
Cabinet width (B)	30"	30"	30"	30"	33"	33"	33"	35¼"
Depth including handles (C)	30⅞"	30⅞"	31¼"	31⅞"	31¼"	31⅞"	30¼"	34⅞"
Height excluding hinges	60"	66"	60"	60"	66"	66"	66"	68"
Depth excluding handles	29¼"	29¼"	30¼"	30¼"	30¼"	30¼"	30¼"	32"
Depth excluding door	24½"	24½"	25½"	25½"	25½"	25½"	25½"	27½"
Depth with door open 90°	55¼"	55¼"	56¼"	56¼"	59¼"	59¼"	59¼"	65¼"
Total volume (cu. ft.)	16.0	17.8	15.8	15.8	20.1	20.1	19.4	24.7
Shipping weight	164 lbs	178 lbs	178 lbs	162 lbs	211 lbs	191 lbs	191 lbs	245 lbs
Available colors	Q	Q	Q	Q	Q	Q	Q	Q

Bold type indicates a step-up feature

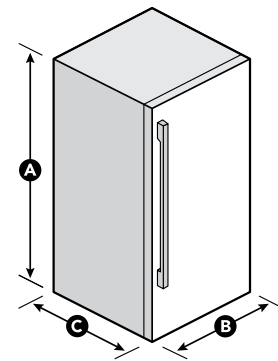

NOTE: Add 1/2" to each side for recessed installation.
ELECTRICAL REQUIREMENTS:
 115V, 60Hz. (Subject to local codes.)
 Listed by Underwriters' Laboratories, Inc.

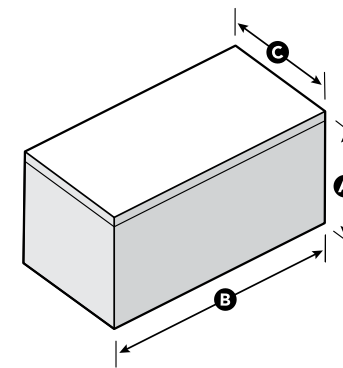

NOTE: Add 1/2" to each side for recessed installation.
ELECTRICAL REQUIREMENTS:
 115V, 60Hz. (Subject to local codes.)
 Listed by Underwriters' Laboratories, Inc.

DIMENSIONS ARE SHOWN FOR PLANNING PURPOSES ONLY.
 For complete information, see Installation Instructions packed with product.

Chest Freezers

SPECIFICATIONS AND DIMENSIONS

MODEL	WHIRLPOOL®	
	EH151FXT	EH185FXT
New 2012 model		
Capacity (cu. ft.)	15	18
Flat textured lid	•	•
Integrated door handle design	•	•
1-Year limited warranty	•	•
PERFORMANCE FEATURES		
ENERGY STAR® qualified	•	•
Defrost drain with hose adapter	•	•
Mechanical controls	•	•
Adjustable thermostat	•	•
Temperature alarm	♦	•
Power On light	♦	•
Interior light	•	•
5-Sided freezer coils	•	•
STORAGE FEATURES		
Solid core lid	•	•
Lid lock with key	•	•
Large storage baskets	2	3
Rounded interior corners	•	•
Dishpan bottom	♦	•
75° Door stops	♦	•
DIMENSIONS AND COLORS		
Height (A)	34¼"	34¼"
Width (B)	46¼"	54"
Depth without handle (C)	28¼"	28¼"
Height with lid open 90°	60⅞"	60⅞"
Carton width	48¼"	56¼"
Carton depth	30¼"	30¼"
Total volume (cu. ft.)	14.8	17.5
Available colors	Q	Q

Bold type indicates a step-up feature

SideKicks® Upright Freezer & Refrigerator

SPECIFICATIONS AND DIMENSIONS

WHIRLPOOL®		
MODEL	EV188NYW All Freezer	EL88TRRW All Refrigerator
Capacity (cu. ft.)	18	18
Flat door style	•	•
Smooth door finish	•	•
Metal handles	•	•
PERFORMANCE FEATURES		
ENERGY STAR® qualified	•	•
Meets CEE Tier standards*	•	Tier 1
Frost-free defrost	•	•
Icemaker ready	ECKMF94	•
Interior light	•	•
Installation wheels	•	•
STORAGE FEATURES		
Door storage	6 gallon bins, 1 gallon shelf	6 gallon bins, 1 gallon shelf
Mid-level storage	1 wire basket	1 meat compartment
Lower storage	1 wire basket	2 clear humidity controlled crispers
Adjustable shelves	4 glass	4 glass
DIMENSIONS AND COLORS		
Height including hinges (A)	66 1/2"	66 1/2"
Cabinet width (B)	30"	30"
Depth including handles (C)	31"	31"
Height excluding hinges	66"	66"
Depth excluding handles	28 1/2"	28 1/2"
Depth excluding door	25 1/2"	24 1/2"
Depth with door open 90°	56 1/2"	56 1/2"
Total volume (cu. ft.)	17.7	17.7
Shipping weight	186 lbs	186 lbs
Available colors	Q S	Q S

Automatic Icemaker

SPECIFICATIONS AND DIMENSIONS

WHIRLPOOL GOLD®	
MODEL	G15NDXX
Storage space	Up to 25 lbs
Ice production per day	Up to 50 lbs
Flat door style	•
Door swing	Reversible
Handle style	Lip
PERFORMANCE FEATURES	
Fast ice	•
Service indicator	•
Electronic Clean cycle	•
Interior light	•
Ice scoop	•
OPTIONAL ACCESSORIES	
Self-install internal drain pump	1901
Trim kit	Q - 8171343 B - 8171345 S - 8171347
Icemaker cleaner	4396808
DIMENSIONS AND COLORS	
Height (A)	33 1/4"–34 1/8"
Width (B)	14 1/8"
Depth including handles (C)	24 1/8"
Depth excluding handles (D)	23 1/8"
Available colors	Q B S

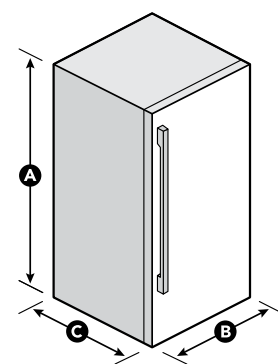

NOTE: Add 1/2" to each side for recessed installation.
ELECTRICAL REQUIREMENTS:
115V, 60Hz. (Subject to local codes.)
Listed by Underwriters' Laboratories, Inc.

*Based on the Consortium for Energy Efficiency qualifying product lists. Visit cee1.org for more information.

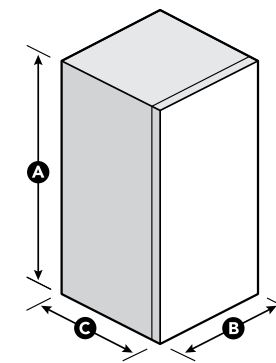

NOTE: Add 1/2" to each side for recessed installation.
ELECTRICAL REQUIREMENTS:
115V, 60Hz. (Subject to local codes.)
Listed by Underwriters' Laboratories, Inc.

Whirlpool brand is constantly improving and innovating our products, so the specifications in this catalog are subject to change.

DIMENSIONS ARE SHOWN FOR PLANNING PURPOSES ONLY. For complete information, see installation instructions packed with product.



VIDEO



COOKING

76	Freestanding ranges	126	Hoods and vents
96	Wall ovens	134	Accessories
104	Cooktops	136	Glossary
118	Microwaves	140	Specifications



WFG710H0AH

FREESTANDING RANGES



Bakes evenly and seals in flavors

The AccuBake® system's built-in sensor monitors oven temperature and the cooking elements to deliver consistent, delicious results every time. Models with TimeSaver™ Plus true convection can even roast up to 30% faster.*

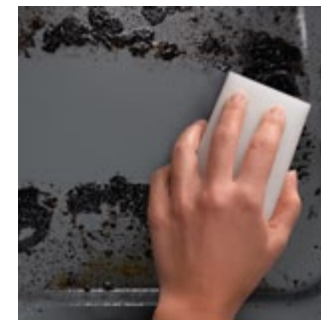

Innovative oven cleaning

AquaLift® self-clean technology offers easy and odor-free oven cleaning in only 50 minutes.** Our most energy-efficient self-cleaning cycle available† uses only water and low heat to release baked-on foods from an innovative coating.



More room with a view

Cook multiple dishes with the industry's largest capacity freestanding range available.†† Check on cooking progress without opening the door with the new EasyView™ extra-large oven window, the industry's largest window available.‡



Boils water in half the time**

Select ranges feature an induction cooktop for faster, more efficient cooking. This advanced technology offers easier cleaning and efficient cooking by transferring energy directly into any magnetic cookware.

NOTE: Not all features are available on all models.

*Versus a conventional oven with a 12–14 lb turkey. **Based on average cleaning time of self-clean cycle with water and moderate soils. †Versus traditional self clean cycle. ††Among leading brand single cavity 30" freestanding gas or electric ranges. ‡Based on interior viewable window of leading brand freestanding ranges. ‡‡Based on boiling 3.6 liters of water with 9" 3,200-watt induction element versus 12,500-BTU gas burner.

Freestanding Electric Ranges

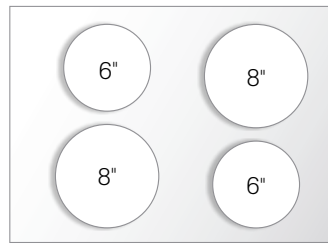

WFC110M0A 4.8 cu. ft. **W**

Upswept porcelain **SpillGuard™** cooktop
Storage drawer



WFC130M0A 4.8 cu. ft. **W | B**

Standard oven window
Upswept porcelain **SpillGuard™** cooktop
Storage drawer

Freestanding Electric Ranges

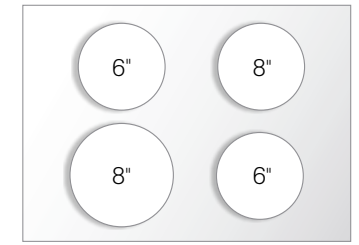

WFC340S0A 4.8 cu. ft. **W | B | S**

Traditional self-cleaning system
Large oven window
ADA compliant*
Upswept porcelain **SpillGuard™** cooktop
Storage drawer



WFC310S0A 4.8 cu. ft. **W | B | T | S**

AccuBake® temperature management system
Traditional self-cleaning system
Large oven window
Upswept porcelain **SpillGuard™** cooktop
Storage drawer

Step-up features highlighted by yellow bar

*Model meets applicable ADA requirements and must be installed in compliance with the current ADA Standards.

Feature descriptions can be found in the [glossary](#) on pages 136–139. [Complete product specifications](#) can be found on page 140.

Freestanding Electric Ranges

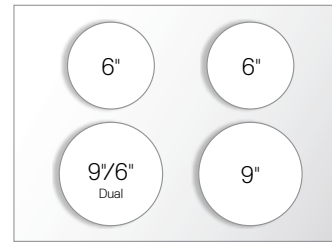

WFE320M0A 4.8 cu. ft. W | B | S

- Step-up features highlighted by yellow bar
- Eco-friendly Schott Ceran® cooktop
- Large oven window
- Storage drawer



WFE330W0A 5.3 cu. ft. W | B | S

- Step-up features highlighted by yellow bar
- AccuBake® temperature management system
- SteamClean option
- Hidden bake element
- Large oven window
- Eco-friendly Schott Ceran® cooktop
- Storage drawer

Freestanding Electric Ranges

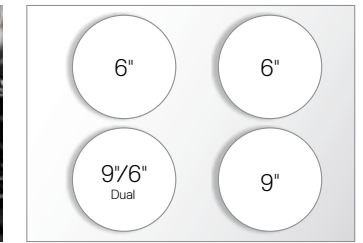

WFE510S0A 4.8 cu. ft. W | B | T | D | S

- Step-up features highlighted by yellow bar
- Traditional self-cleaning system
- AccuBake® temperature management system
- Large oven window
- Eco-friendly Schott Ceran® cooktop
- Storage drawer

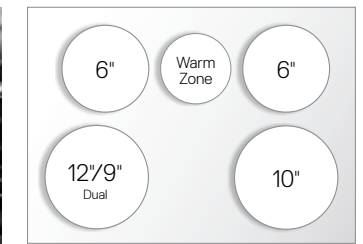

WFE520C0A 5.3 cu. ft. W | B | S

- Step-up features highlighted by yellow bar
- SteamClean option
- Hidden bake element
- AccuBake® temperature management system
- Traditional self-cleaning system
- Large oven window
- Eco-friendly Schott Ceran® cooktop
- Storage drawer

Step-up features highlighted by yellow bar

Feature descriptions can be found in the [glossary](#) on pages 136–139. Complete product specifications can be found on pages 140–141.

Freestanding Electric Ranges

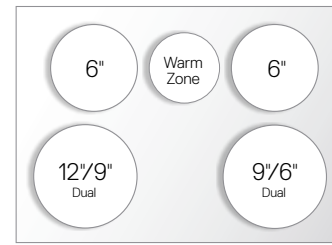

WFE540H0A 6.2 cu. ft. W | B | S | H | E

- TimeSavor™ convection**
- AquaLift® self-clean technology**
- New EasyView™ extra-large oven window**
- Hidden bake element with thermal vents**
- Energy Save mode**
- White Ice and Black Ice color options
- AccuBake® temperature management system
- Eco-friendly Schott Ceran® cooktop
- Storage drawer

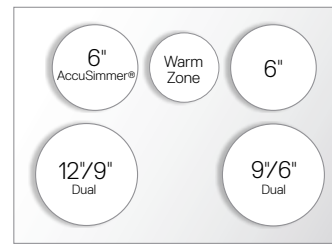

WFE710H0A 6.2 cu. ft. S | H | E

- Whirlpool Gold® model
- TimeSavor™ Plus true convection**
- Rapid Preheat**
- Adjustable split rack**
- Convection Conversion**
- AccuBake® temperature management system
- AquaLift® self-clean technology
- New EasyView™ extra-large oven window
- Hidden bake element with thermal vents
- Eco-friendly Schott Ceran® cooktop
- Energy Save mode
- Storage drawer
- White Ice and Black Ice color options

Freestanding Electric Ranges

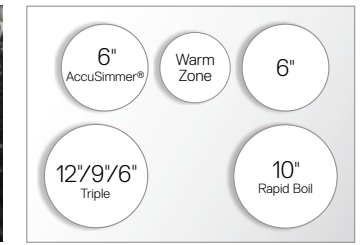

WFE720H0A 6.2 cu. ft. S

- Whirlpool Gold® model
- Rapid Boil element**
- Adjustable warming drawer with handle
- AccuBake® temperature management system
- TimeSavor™ Plus true convection
- AquaLift® self-clean technology
- Rapid Preheat
- New EasyView™ extra-large oven window
- Adjustable split rack
- Convection Conversion
- Hidden bake element with thermal vents
- Eco-friendly Schott Ceran® cooktop
- Energy Save mode



WFI910H0A 6.2 cu. ft. Induction Range S

- Whirlpool Gold® model
- Induction cooking technology**
- AccuBake® temperature management system
- TimeSavor™ Plus true convection
- AquaLift® self-clean technology
- Rapid Preheat
- New EasyView™ extra-large oven window
- Adjustable split rack
- Convection Conversion
- Hidden bake element with thermal vents
- Adjustable warming drawer with handle
- Eco-friendly Schott Ceran® cooktop
- Energy Save mode

Step-up features highlighted by yellow bar

Feature descriptions can be found in the [glossary](#) on pages 136–139. Complete product specifications can be found on page 141.

Freestanding Gas Ranges



9,500	9,500
9,500	9,500

WFG110AV 4.4 cu. ft. Q

Steel grates
Broiler drawer



9,500	9,500
9,500	9,500

WFG111SV 4.4 cu. ft. Q

Standard oven window
Steel grates
Broiler drawer

Freestanding Gas Ranges



9,500	9,500
11,500	9,500

WFG114SW 4.4 cu. ft. Q | B | T

Cast-iron grates
Standard oven window
Broiler drawer



7,000	7,000
8,000	7,000
7,500 Oval	

WFG231LV 4.4 cu. ft. Q | B | S

Large oven window
Center griddle included
Oval burner
Cast-iron grates
Broiler drawer

Step-up features highlighted by yellow bar

NOTE: Cooktop BTUs are listed for each model.

Feature descriptions can be found in the [glossary](#) on pages 136–139. Complete product specifications can be found on page 142.

Freestanding Gas Ranges

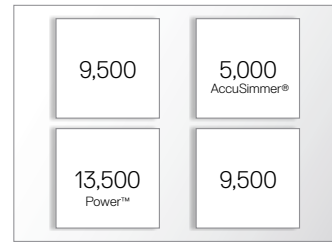

WFG510S0A 5.0 cu. ft. **W | B | T | D | S**

AccuBake® temperature management system

Traditional self-cleaning system

Satin-finish, **cast-iron grates**

Storage drawer

Large oven window

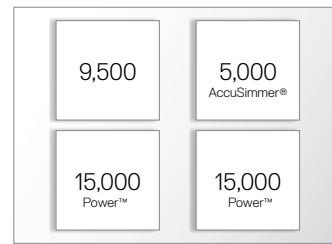

WFG520S0A 5.0 cu. ft. **W | B | S**

Full-width, satin-finish **cast-iron grates**

AccuBake® temperature management system

Traditional self-cleaning system

Large oven window

Storage drawer

Step-up features highlighted by yellow bar

Freestanding Gas Ranges

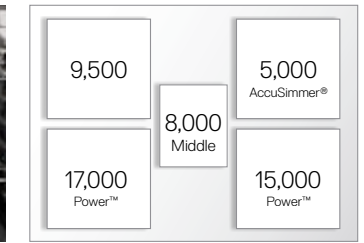

WFG540H0A 5.8 cu. ft. **W | B | S | H | E**

TimeSavor™ convection

AquaLift® self-clean technology

New EasyView™ extra-large oven window

Energy Save mode

Middle burner

White Ice and Black Ice color options

AccuBake® temperature management system

Full-width, satin-finish cast-iron grates

Storage drawer

NOTE: Cooktop BTUs are listed for each model.

Feature descriptions can be found in the [glossary](#) on pages 136–139. Complete product specifications can be found on page 143.

Freestanding Gas Ranges

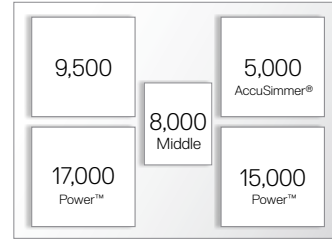

WFG710H0A 5.8 cu. ft. S | H | E

Whirlpool Gold® model

- Rapid Preheat**
- Adjustable split rack**
- Convection Conversion**
- Side-integrated griddle included
- AccuBake® temperature management system
- TimeSavor™ convection
- AquaLift® self-clean technology
- New EasyView™ extra-large oven window
- Full-width, satin-finish cast-iron grates
- Middle burner
- Energy Save mode
- Storage drawer
- White Ice and Black Ice color options

Step-up features highlighted by yellow bar

Freestanding Gas Ranges

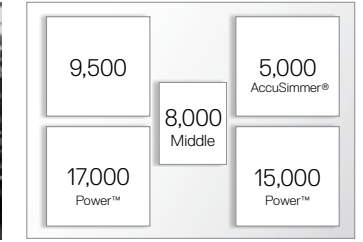

WFG720H0A 5.8 cu. ft. S

Whirlpool Gold® model

- TimeSavor™ Plus true convection**
- Adjustable warming drawer with handle
- AccuBake® temperature management system
- AquaLift® self-clean technology
- Rapid Preheat
- New EasyView™ extra-large oven window
- Adjustable split rack
- Convection Conversion
- Side-integrated griddle included
- Full-width, satin-finish cast-iron grates
- Middle burner
- Energy Save mode

NOTE: Cooktop BTUs are listed for each model.

Feature descriptions can be found in the [glossary](#) on pages 136–139. Complete product specifications can be found on page 143.

Freestanding Double Oven Electric Ranges

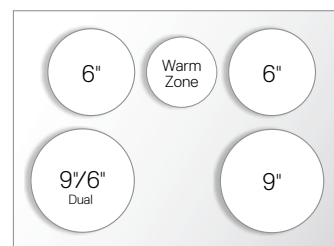

GGE388LX 6.7 total cu. ft. Q | B | S

Whirlpool Gold® model
Eco-friendly Schott Ceran® cooktop

LOWER OVEN

EasyView™ extra-large oven window

BOTH OVENS

Energy Save mode
Precise Clean™ self-cleaning system
AccuBake® temperature management system

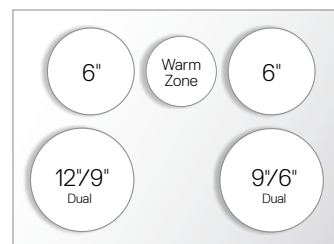

GGE390LX 6.7 total cu. ft. Q | B | S

Whirlpool Gold® model
Eco-friendly Schott Ceran® cooktop

LOWER OVEN

TimeSavor™ Plus true convection
EasyView™ extra-large oven window

BOTH OVENS

SteamClean option
Hidden bake element
Energy Save mode
Precise Clean™ self-cleaning system
AccuBake® temperature management system

Step-up features highlighted by yellow bar

Freestanding Double Oven Gas Ranges

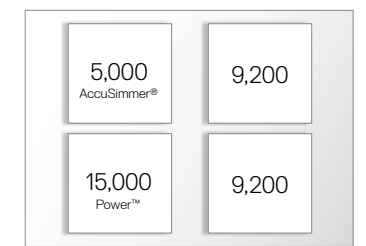

GGG388LX 6.0 total cu. ft. Q | B | S

Whirlpool Gold® model
Full-width, satin-finish cast-iron grates

LOWER OVEN

EasyView™ extra-large oven window

BOTH OVENS

Energy Save mode
Precise Clean™ self-cleaning system
Hidden bake element
AccuBake® temperature management system

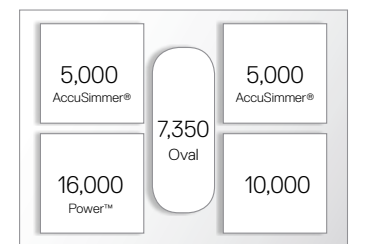

GGG390LX 6.0 total cu. ft. Q | B | S

Whirlpool Gold® model

Oval burner

Full-width, satin-finish cast-iron grates

LOWER OVEN

TimeSavor™ convection
EasyView™ extra-large oven window

BOTH OVENS

Energy Save mode
Precise Clean™ self-cleaning system
Hidden bake element
AccuBake® temperature management system

NOTE: Cooktop BTUs are listed for each model.

Feature descriptions can be found in the [glossary](#) on pages 136–139. Complete product specifications can be found on page 144.

Slide-In Electric Ranges

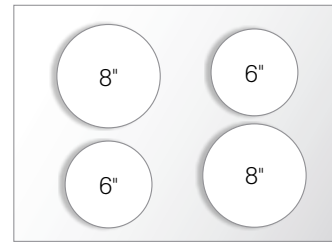

RY160LXT 4.3 cu. ft. Q | B | S

Precise Clean™ self-cleaning system
Extra-large oven window

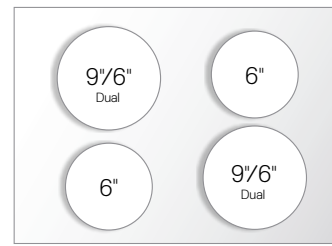

GY397LXU 4.5 cu. ft. Q | B | S

Whirlpool Gold® model
AccuBake® temperature management system
Eco-friendly Schott Ceran® cooktop
Precise Clean™ self-cleaning system
Extra-large oven window

Step-up features highlighted by yellow bar

Slide-In Electric Ranges

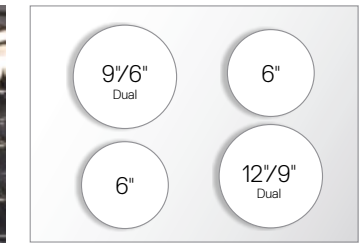

GY399LXU 4.5 cu. ft. Q | B | S

Whirlpool Gold® model
TimeSaver™ Plus true convection
Hidden bake element
AccuBake® temperature management system
Precise Clean™ self-cleaning system
Extra-large oven window
Eco-friendly Schott Ceran® cooktop

Feature descriptions can be found in the [glossary](#) on pages 136–139. Complete product specifications can be found on page 145.

Slide-In Gas Ranges



5,000	9,200
9,200	14,000 Power™

GW397LXU 4.5 cu. ft. Q | B | S

- Whirlpool Gold® model
- AccuBake® temperature management system
- Precise Clean™ self-cleaning system
- Extra-large oven window
- Continuous satin-finish, cast-iron grates
- Hidden bake element



5,000	9,200
12,500 Power™	16,000 Power™

GW399LXU 4.5 cu. ft. Q | B | S

- Whirlpool Gold® model
- TimeSaver™ Plus true convection**
- AccuBake® temperature management system
- Precise Clean™ self-cleaning system
- Extra-large oven window
- Continuous satin-finish, cast-iron grates
- Hidden bake element

Drop-In Electric Ranges



8"	6"
6"	8"

WDE150LV 4.5 cu. ft. Q | B | S

- AccuBake® temperature management system
- Self-cleaning system with Delay Clean
- Large oven window



9/6" Dual	6"
6"	9/6" Dual

WDE350LV 4.5 cu. ft. Q | B | S

- Eco-friendly Schott Ceran® cooktop**
- AccuBake® temperature management system
- Self-cleaning system with Delay Clean
- Large oven window

NOTE: Cooktop BTUs are listed for each model.

Step-up features highlighted by yellow bar

Feature descriptions can be found in the [glossary](#) on pages 136–139. Complete product specifications can be found on pages 145–146.



WALL OVENS



Seals in flavors and bakes evenly

TimeSavor™ Ultra true convection uses a rear fan and a third element on select models to cut roasting time and seal in juices. The AccuBake® system also surrounds food with even temperatures to achieve consistent results every time.



Cleans easily

The SteamClean option makes cleanup easy. It spot cleans everyday light spills using only heat and 1-1/4 cups of water—no harsh chemicals or cleaners needed.



Sophisticated design

The sleek styling of new handles and color options adds a modern look that completes any kitchen. Plus, replacing your wall oven just got easier. With the FIT system, your wall oven can fit seamlessly into your current cabinet cutout.*



Largest capacity wall oven available**

Cook multiple dishes for a large family meal or prepare treats for a bake sale with double oven capacities of up to 10.0 total cu. ft. Now there's plenty of room to handle even your largest cooking tasks.

NOTE: Not all features are available on all models.

*Available on 27" and 30" double and single wall ovens. See product specifications for minimum and maximum installation dimensions.

**Among leading brand 27" or 30" wall ovens.

Single Wall Ovens



RBS245PR 24" 3.1 cu. ft. Q | B | T | S
 AccuBake® temperature management system
 Large oven window



**RATED A
 BEST
 BUY**

WOS51EC0A 30" 5.0 cu. ft. W | B | T | S
WOS51EC7A 27" 4.3 cu. ft. W | B | S
 SteamClean option
 FIT system
 New EasyView™ extra-large oven window
 Hidden bake element
 AccuBake® temperature management system

*According to a leading consumer magazine, model WOS51EC0A only. **FIT System Limited Guarantee: If our 27" or 30" standard single or double wall ovens featuring the FIT System do not fit your existing cabinet cut-out of a compatible width and configuration, contact us within 30 days of the purchase date and receive up to \$250 toward the cost of professional cabinet modification. Valid for qualified replacement models purchased between 5/1/12–12/31/12; excludes new cabinet installations. Visit whirlpool.com/fitsystemlimitedguarantee for complete details.

Step-up features highlighted by yellow bar



All 27" and 30" single oven models are backed by the Fit System Limited Guarantee to fit your existing cabinet cutout.**

Single Wall Ovens



**#1
 RATED†**

WOS92EC0A 30" 5.0 cu. ft. W | B | S | H | E
WOS92EC7A 27" 4.3 cu. ft. W | B | S
 Whirlpool Gold® model
 TimeSavor™ Ultra true convection cooking
 Rapid Preheat
 Convection Conversion
 White Ice and Black Ice color options††
 AccuBake® temperature management system
 SteamClean option
 FIT system
 New EasyView™ extra-large oven window
 Hidden bake element

†According to a leading consumer magazine, model WOS92EC0A only. ††Model WOS92EC0A only.

Feature descriptions can be found in the [glossary](#) on pages 136–139. Complete product specifications can be found on page 147.

Double Wall Ovens



RBD245PR 24" 6.2 total cu. ft. Q | B | T | S
 AccuBake® temperature management system
 Large oven window



WOD51EC0A 30" 10.0 total cu. ft. W | B | T | S
WOD51EC7A 27" 8.6 total cu. ft. W | B | S
 SteamClean option
 FIT system
 New EasyView™ extra-large oven window
 Hidden bake element
 AccuBake® temperature management system

Double Wall Ovens



WOD93EC0A 30" 10.0 total cu. ft. W | B | S | H | E
WOD93EC7A 27" 8.6 total cu. ft. W | B | S

Whirlpool Gold® model

TimeSaver™ Ultra true convection

Rapid Preheat

Convection Conversion

White Ice and Black Ice color options**

AccuBake® temperature management system

SteamClean option

FIT system

New EasyView™ extra-large oven window

Hidden bake element

*FIT System Limited Guarantee: If our 27" or 30" standard single or double wall ovens featuring the FIT System do not fit your existing cabinet cut-out of a compatible width and configuration, contact us within 30 days of the purchase date and receive up to \$250 toward the cost of professional cabinet modification. Valid for qualified replacement models purchased between 5/1/12-12/31/12; excludes new cabinet installations. Visit whirlpool.com/fitsystemlimitedguarantee for complete details.

Step-up features
 highlighted by
 yellow bar



All 27" and 30" double oven models are backed by the Fit System Limited Guarantee to fit your existing cabinet cut-out.*

**Model WOD93EC0A only.

Feature descriptions can be found in the glossary on pages 136-139. Complete product specifications can be found on page 148.

Combination Microwave Wall Ovens



WOC54EC0A 30" 6.4 total cu. ft. W | B | S
WOC54EC7A 27" 5.7 total cu. ft. W | B | S

AccuBake® temperature management system
 SteamClean option
 New EasyView™ extra-large oven window
 Hidden bake element
 Sensor microwave with drop-down door

Combination Microwave Wall Ovens



WOC95EC0A 30" 6.4 total cu. ft. W | B | S | H | E

Whirlpool Gold® model

TimeSavor™ Ultra true convection

Rapid Preheat

Convection Conversion

White Ice and Black Ice color options

AccuBake® temperature management system

SteamClean option

New EasyView™ extra-large oven window

Hidden bake element

Sensor microwave with drop-down door

Step-up features highlighted by yellow bar

Feature descriptions can be found in the [glossary](#) on pages 136–139. Complete product specifications can be found on page 149.



COOKTOPS



Offers flexible cooking options

Whirlpool® electric cooktops simmer, sear and melt quickly and easily with triple radiant elements, bridge elements and our first ever 30" cooktop with five elements. The 17,000-BTU Flex Power™ burner also achieves high heat to quickly boil water.



Boils water in up to half the time*

The Boost function dramatically increases power for greater cooking flexibility and immediate responsiveness. Faster boiling helps you prepare tea, pasta and soup more quickly. You'll even sauté and fry faster, too.



Delivers innovative Induction technology

The Induction cooktop transfers energy directly into any magnetic cookware for faster, more energy-efficient cooking, making it our most energy-efficient cooktop ever. Because the cooking surface cools down fast, spills won't bake onto it.



Precise temperature control

Master your most delicate dishes with the precise temperature control from AccuSimmer® elements and burners. Now you can easily melt butter, cook custards and simmer sauces. The AccuSimmer® Plus element offers more control and reaches lower temperatures.

NOTE: Not all features are available on all models.

*Compared to boiling 3.6 liters of water with a traditional 9" 2,500-watt radiant element or a 12,500-BTU gas burner.

Electric Cooktops

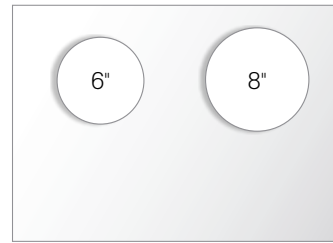

RCS2012R 21" S

- High-speed coil elements
- Infinite heat controls
- Chrome drip bowls

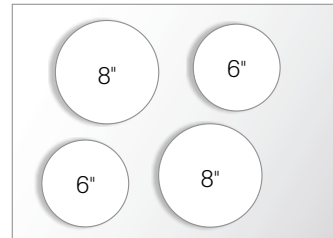

WCC31430A 30" W | B | R

- Dishwasher-safe control knobs
- No Drip chrome drip bowls
- High-speed coil elements
- Infinite heat controls

Step-up features highlighted by yellow bar

Electric Cooktops

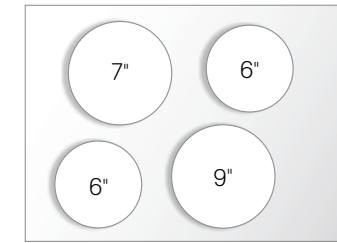
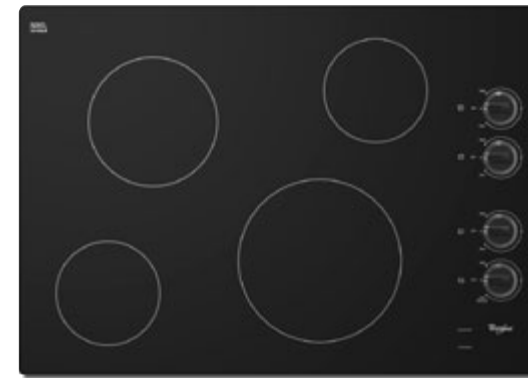

W5CE3024X 30" W | B | S

- Eco-friendly Schott Ceran® cooktop
- Ceramic glass radiant elements
- Dishwasher-safe control knobs
- Infinite heat controls

RATED A
BEST
BUY

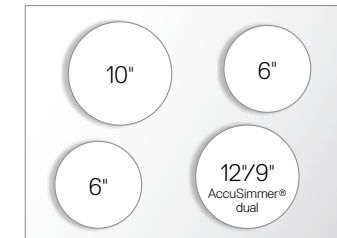
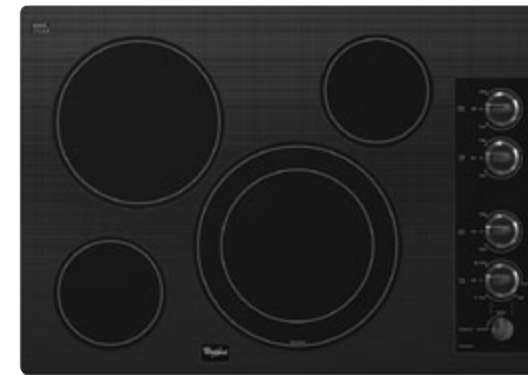

G7CE3034X 30" P | B | C | S

- Whirlpool Gold® model
- AccuSimmer® Dual radiant element
- Dishwasher-safe, Stainless steel finish control knobs**
- Ceramic glass radiant elements
- Eco-friendly Schott Ceran® cooktop†
- Infinite heat controls

*According to a leading consumer magazine. **Stainless Steel models only. †Eco-friendly designation does not apply to Pure White and Pure Biscuit Schott Ceran® cooktops. Feature descriptions can be found in the [glossary](#) on pages 136–139. [Complete product specifications](#) can be found on page 150.

Electric Cooktops

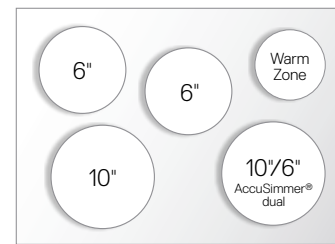
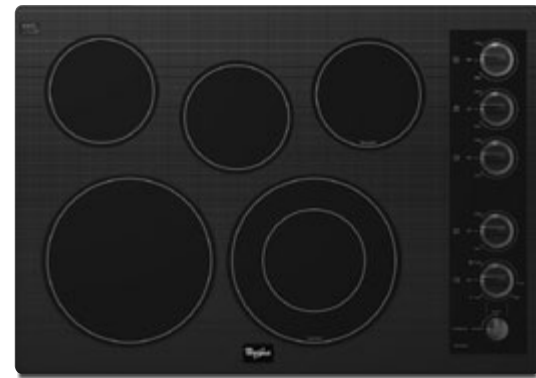

G7CE3055X 30" B | S

Whirlpool Gold® model

5 ceramic glass radiant elements

Warm Zone element

Eco-friendly Schott Ceran® cooktop

AccuSimmer® Dual radiant element

Dishwasher-safe, Stainless steel finish control knobs†

Infinite heat controls

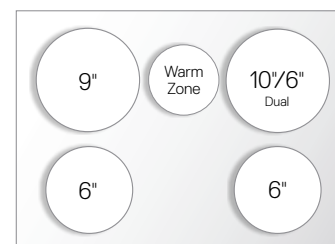

G9CE3065X 30" B | S

Whirlpool Gold® model

AccuSimmer® Plus feature on all elements

Tap Touch controls

Control lock

ADA compliant**

5 ceramic glass radiant elements

Eco-friendly Schott Ceran® cooktop

Dual radiant element

Warm Zone element

Electric Cooktops

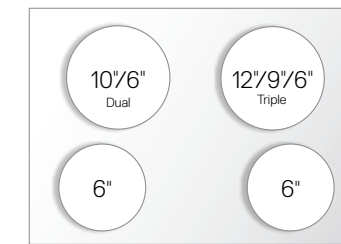

G9CE3074X 30" B | S

Whirlpool Gold® model

Triple radiant element

Ceramic glass radiant elements

Eco-friendly Schott Ceran® cooktop

AccuSimmer® Plus feature on all elements

Tap Touch controls

Dual radiant element

Control lock

ADA compliant**

RATED A
BEST
BUY†



GCI3061X 30" Induction Cooktop B

Whirlpool Gold® model

Boost function element

Induction elements

Automatic pan detection

Eco-friendly Schott Ceran® cooktop

Tap Touch controls

Control lock

ADA compliant**

*Stainless Steel models only. **Meets ADA push/pull force and reach guidelines.

Step-up features
highlighted by
yellow bar

**Meets ADA push/pull force and reach guidelines. †According to a leading consumer magazine.

Feature descriptions can be found in the [glossary](#) on pages 136–139. [Complete product specifications](#) can be found on pages 150–151.

Electric Cooktops

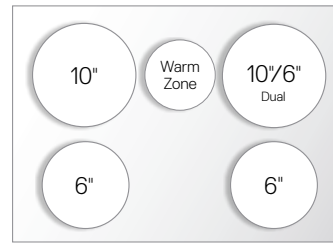
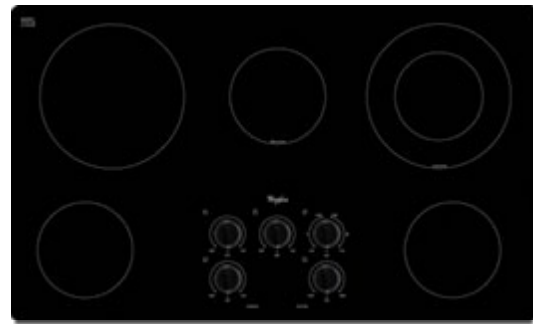

W5CE3625A 36" B

5 ceramic glass radiant elements
Eco-friendly Schott Ceran® cooktop
Dishwasher-safe control knobs
Dual radiant element
Warm Zone element
Infinite heat controls

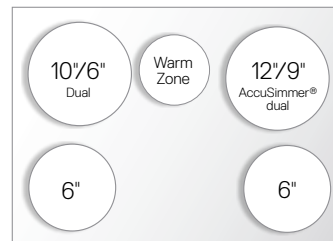

G7CE3635X 36" P | B | S

Whirlpool Gold® model
AccuSimmer® element
Dishwasher-safe, Stainless steel finish control knobs*
Multiple Dual radiant elements
5 ceramic glass radiant elements
Eco-friendly Schott Ceran® cooktop**
Warm Zone element
Infinite heat controls

Electric Cooktops

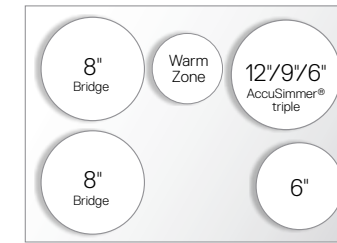

G7CE3655X 36" B | S

Whirlpool Gold® model
AccuSimmer® Triple radiant element
Bridge elements
5 ceramic glass radiant elements
Eco-friendly Schott Ceran® cooktop
Dishwasher-safe, Stainless steel finish control knobs*
Warm Zone element
Infinite heat controls

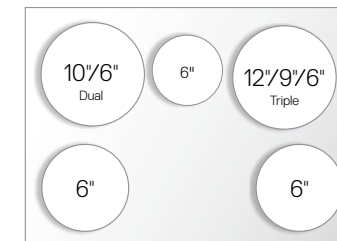

G9CE3675X 36" B | S

Whirlpool Gold® model
AccuSimmer® Plus feature on all elements
Tap Touch controls
Dual radiant element
Control lock
ADA compliant†
5 ceramic glass radiant elements
Eco-friendly Schott Ceran® cooktop
Triple radiant element

*Stainless Steel models only. **Eco-friendly designation does not apply to Pure White Schott Ceran® cooktops.

Step-up features highlighted by yellow bar

*Stainless Steel models only. †Meets ADA push/pull force and reach guidelines

Feature descriptions can be found in the [glossary](#) on pages 136–139. Complete product specifications can be found on page 151.

Gas Cooktops



9,100	9,100
10,500	5,000 AccuSimmer®

W3CG3014X 30" W | B | S

Porcelain or Stainless steel cooktop
AccuSimmer® burner
 Dishwasher-safe, enamel steel grates
 Control knobs
Sealed burners
 Infinite heat controls
 ADA compliant*

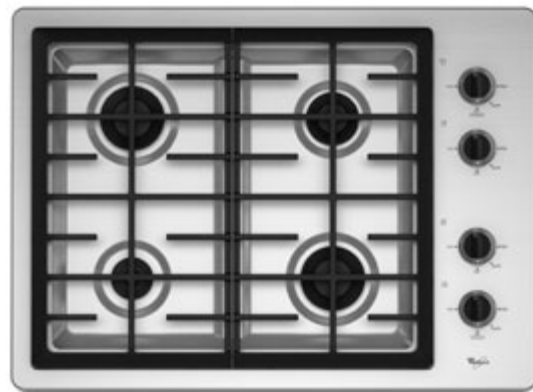

12,500 Power™	9,200
5,000 AccuSimmer®	12,500 Power™

W5CG3024X 30" W | B | T | S

Dishwasher-safe, full-width **cast-iron grates**
 Dishwasher-safe control knobs
Multiple Power™ burners
 Porcelain or Stainless steel cooktop
AccuSimmer® burner
Sealed burners
 Infinite heat controls
 ADA compliant*

Gas Cooktops



9,100	6,000 AccuSimmer®
12,500 Power™	12,500 Power™

GLT3057R 30" B

Whirlpool Gold® model
 Tempered glass cooktop
AccuSimmer® burner
 Dishwasher-safe, full-width **cast-iron grates**
 Dishwasher-safe control knobs
Sealed burners
Multiple Power™ burners
 Infinite heat controls



9,200	15,000 Power™
17,000 Power™	5,000 AccuSimmer®

G7CG3064X 30" B | S

Whirlpool Gold® model
 Dishwasher-safe, Stainless steel finish control knobs**
ADA compliant*
 Porcelain or Stainless steel cooktop
Multiple Power™ burners
AccuSimmer® burner
 Dishwasher-safe, full-width **cast-iron grates**
Sealed burners
 Infinite heat controls

*Meets ADA push/pull force and reach guidelines.

Step-up features highlighted by yellow bar

*Meets ADA push/pull force and reach guidelines. **Stainless Steel models only.

NOTE: Cooktop BTUs are listed for each model.

Feature descriptions can be found in the [glossary](#) on pages 136–139. [Complete product specifications](#) can be found on page 152.

Gas Cooktops

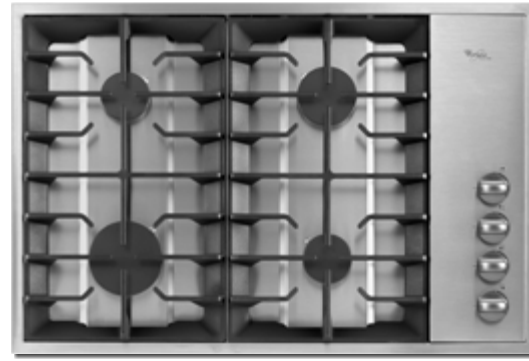

9,000	12,000 Power™
15,000 Power™	9,000

GLS3064R 30" S

Whirlpool Gold® model

Recessed grate design

Stainless steel cooktop

Dishwasher-safe, full-width [cast-iron grates](#)

Stainless steel finish control knobs

Sealed burners

Multiple [Power™](#) burners

Infinite heat controls



9,200	5,000 AccuSimmer®	9,200
9,200		12,500 Power™

W5CG3625X 36" W | B | S

AccuSimmer® burner

ADA compliant*

Porcelain or Stainless steel cooktop

Dishwasher-safe, full-width [cast-iron grates](#)

Dishwasher-safe control knobs

Sealed burners

[Power™](#) burner

Infinite heat controls

*Meets ADA push/pull force and reach guidelines.

Step-up features highlighted by yellow bar

Gas Cooktops



6,000 AccuSimmer®	9,100	6,000 AccuSimmer®
12,500 Power™		12,500 Power™

GLT3657R 36" B

Whirlpool Gold® model

Multiple AccuSimmer® burners

Multiple Power™ burners

Tempered glass cooktop

Dishwasher-safe, full-width [cast-iron grates](#)

Dishwasher-safe control knobs

Sealed burners

Infinite heat controls

NOTE: Cooktop BTUs are listed for each model.

Feature descriptions can be found in the [glossary](#) on pages 136–139. [Complete product specifications](#) can be found on page 152.

Gas Cooktops

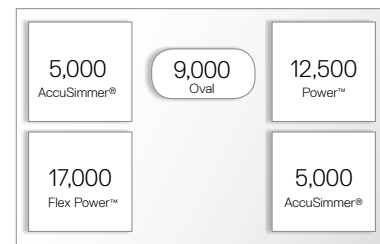

G7CG3665X 36" B | S

Whirlpool Gold® model

Flex Power™ burner

Dishwasher-safe, Stainless steel finish control knobs†

Oval burner

ADA compliant**

Porcelain or Stainless steel cooktop

Multiple AccuSimmer® burners

Dishwasher-safe, full-width cast-iron grates

Sealed burners

Power™ burner

Infinite heat controls

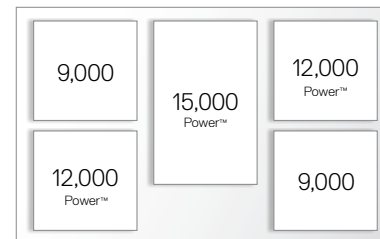
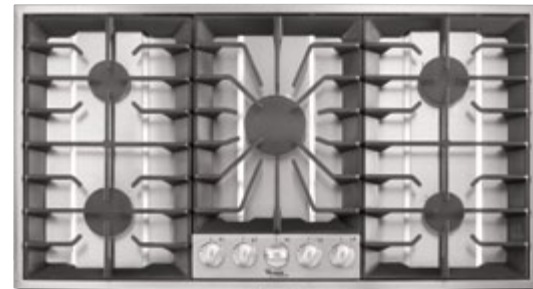

GLS3665R 36" S

Whirlpool Gold® model

Multiple Power™ burners

Recessed grate design

Stainless steel cooktop

Dishwasher-safe, full-width cast-iron grates

Stainless steel finish control knobs

Sealed burners

Infinite heat controls

Modular Cooktop

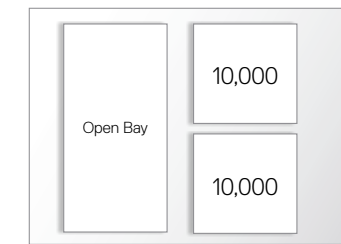

SC8720ED 30" Modular Cooktop B

Modular cooktop surface

Dishwasher-safe, lift off control knobs

Infinite heat controls

Downdraft vent

Removable/washable vent filter

Optional modules available: surface burner, non-stick grill and non-stick griddle†

*Stainless Steel models only. **Meets ADA push/pull force and reach guidelines.

Step-up features highlighted by yellow bar

†Cooktop is shipped with one open bay and two fixed burners. Select from the module options to complete your cooktop.

NOTE: Cooktop BTUs are listed for each model.

Feature descriptions can be found in the [glossary](#) on pages 136–139. Complete product specifications can be found on pages 152–153.



WMH53520AE

MICROWAVES



Adjusts cooking time for optimal results

With the push of a single button, Sensor cooking tracks the progress of your food. It automatically adjusts cooking time as needed so you won't have to micro-manage your microwave.



Senses cooktop heat

Select Whirlpool® microwaves automatically adjust fan speed by sensing cooktop heat. Models with the Auto Adapt fan also offer variable fan speeds so you can match the right amount of ventilation to the dish being prepared.



Seals in flavors and juices

TimeSavor™ Plus true convection cooks food evenly with juicy, flavorful results. It uses a rear fan to circulate preheated air over, under and around food so you can roast up to 30% faster than traditional thermal-bake ovens.



Convenient steaming

Enjoy flaky fish, tender vegetables and fluffy rice quickly and easily with Steam cooking. Now you can steam in the microwave for delicious, healthy meals.

NOTE: Not all features are available on all models.

Microwave Hood Combinations

Microwave Hood Combinations



WMH31017A 1.7 cu. ft. W | B | D | S

Recessed glass turntable
EZ-View™ lighting



WMH53520A 2.0 cu. ft. W | B | S | H | E

Auto Adapt fan
CleanRelease® non-stick interior
White Ice and Black Ice color options
Sensor cooking
Steam cooking
Recessed, stoppable glass turntable
AccuSimmer® cycle
Cooking rack
EZ-View™ lighting



WMH32517A 1.7 cu. ft. W | B | T | S

Sensor cooking
Steam cooking
Recessed, stoppable glass turntable
AccuSimmer® cycle
Cooking rack
EZ-View™ lighting



WMH75520A 2.0 cu. ft. W | B | S

Whirlpool Gold® model
AccuWave® power system
Sensor cooking
Steam cooking
CleanRelease® non-stick interior
Recessed, stoppable glass turntable
AccuSimmer® cycle
Cooking rack
EZ-View™ lighting

Step-up features highlighted by yellow bar

Feature descriptions can be found in the [glossary](#) on pages 136–139. Complete product specifications can be found on page 154.

Microwave Hood Combinations



WMH76718A 1.8 cu. ft. W | B | S

- Whirlpool Gold® model
- TimeSaver™ Plus true convection**
- Cooking and convection racks
- Sensor cooking
- Steam cooking
- CleanRelease® non-stick interior
- Recessed, stoppable glass turntable
- AccuSimmer® cycle
- EZ-View™ lighting



GH7208XR 2.0 cu. ft. Q | B | S | Y

- Whirlpool Gold® model
- AccuWave® power system**
- SpeedCook technology** with grilling
- Grill rack
- Halogen lighting
- Touch screen controls
- Sensor cooking
- TimeSaver™ Plus true convection
- Steam cooking
- CleanRelease® non-stick interior
- Recessed, stoppable glass turntable
- AccuSimmer® cycle

RATED A
RECOMMENDED BUY*

Countertop Microwaves



WMC10007A 0.7 cu. ft. W | B

- Turntable
- Electronic touch controls
- Add-a-Minute option
- Control lock



WMC10511A 1.1 cu. ft. W | B

- Sensor cooking**
- Recessed glass turntable
- Add 30 seconds option**
- Electronic touch controls
- Control lock

*According to a leading consumer magazine.

Step-up features
highlighted by
yellow bar

Feature descriptions can be found in the [glossary](#) on pages 136–139. Complete product specifications can be found on pages 154–155.

Countertop Microwaves



WMC11511A 1.1 cu. ft. **S**
Sensor cooking
Recessed glass turntable
Electronic touch controls
Add 30 seconds option
Control lock



WMC30516A 1.6 cu. ft. **W | B | S**
Sensor cooking
Recessed glass turntable
Electronic touch controls
Add 30 seconds option
Control lock

Step-up features
highlighted by
yellow bar

Countertop Microwaves



WMC20005Y 0.5 cu. ft. **W | B | D**
Tap Touch controls
Rounded-back design
Glass turntable
Add 30 seconds option
Control lock

Feature descriptions can be found in the [glossary](#) on pages 136–139. Complete product specifications can be found on page 155.

Under Cabinet Hoods



UXT2030AY 30" Traditional W | B
UXT2036AY 36" Traditional W | B

Up to 190 CFM
Axial fan
Top venting only
Dishwasher-safe grease filter
2-speed rocker switch controls
Incandescent light



UXT3030AY 30" Traditional W | B
UXT3036AY 36" Traditional W | B

Top and rear venting
Up to 190 CFM
Axial fan
Dishwasher-safe grease filter
2-speed rocker switch controls
Incandescent light

Step-up features highlighted by yellow bar

Under Cabinet Hoods



UXT4030AY 30" Traditional W | B | T | S
UXT4036AY 36" Traditional W | B

Recirculation kit/Charcoal filter included
Axial fan
Recirculating only
2-speed rocker switch controls
Incandescent light



UXT4230AY 30" Traditional W | B | T | S
UXT4236AY 36" Traditional W | B | S

Up to 225 CFM
Convertible (recirculating or vented)
Dishwasher-safe grease filter
Variable-speed rotary controls
Adjustable incandescent light
Axial fan
Optional Recirculation kit/Charcoal filter

Feature descriptions can be found in the [glossary](#) on pages 136–139. Complete product specifications can be found on page 156.

Under Cabinet Hoods



UXT5230AY 30" Traditional W | B | S
UXT5236AY 36" Traditional W | B | S

- Up to 350 CFM
- 3-speed push-button controls
- Adjustable halogen light
- Axial fan
- Convertible (recirculating or vented)
- Dishwasher-safe grease filter
- Optional Recirculation kit/Charcoal filter



UXT5530AA 30" High Performance S
UXT5536AA 36" High Performance S

- Up to 400 CFM
- Centrifugal fan
- Multiple dishwasher-safe grease filters
- Recirculation kit/Charcoal filter included
- Convertible (recirculating or vented)
- 3-speed push-button controls
- Adjustable halogen light

Under Cabinet Hoods



GXU7130DX 30" Traditional S

- Whirlpool Gold® model
- ENERGY STAR® qualified**
- Fluorescent light
- Up to 300 CFM
- Centrifugal fan
- Vented only
- Multiple dishwasher-safe grease filters
- 3-speed push-button controls

Step-up features highlighted by yellow bar



Select Whirlpool® hoods are ENERGY STAR® qualified.

Feature descriptions can be found in the [glossary](#) on pages 136–139. Complete product specifications can be found on page 156.

Canopy Hoods



GXW6530DX 30" Glass Wall Mounted S
GXW6536DX 36" Glass Wall Mounted S

- Whirlpool Gold® model
- Up to 400 CFM
- Centrifugal fan
- Convertible (recirculating or vented)
- Dishwasher-safe grease filter
- 3-speed push-button controls
- Incandescent light
- Optional Recirculation kit/Charcoal filter



GXI6536DX 36" Glass Island S

- Whirlpool Gold® model
- Halogen light**
- Up to 400 CFM
- Centrifugal fan
- Convertible (recirculating or vented)
- Dishwasher-safe grease filter
- 3-speed push-button controls
- Optional Recirculation kit/Charcoal filter

Canopy Hoods

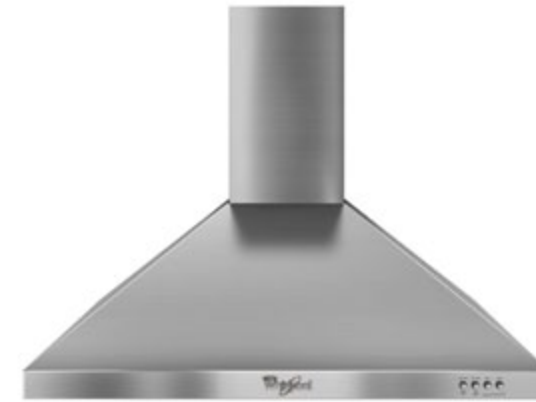

GXW7230DA 30" Wall Mounted S

- Whirlpool Gold® model
- Multiple dishwasher-safe grease filters**
- Up to 400 CFM
- Centrifugal fan
- Convertible (recirculating or vented)
- 3-speed push-button controls
- Adjustable incandescent light
- Optional Recirculation kit/Charcoal filter



GXW7330DX 30" Wall Mounted S
GXW7336DX 36" Wall Mounted S

- Whirlpool Gold® model
- ENERGY STAR® qualified**
- Fluorescent light
- Up to 300 CFM
- Centrifugal fan
- Convertible (recirculating or vented)
- Multiple dishwasher-safe grease filters
- 3-speed push-button controls
- Optional Recirculation kit/Charcoal filter

Step-up features highlighted by yellow bar



Select Whirlpool® hoods are ENERGY STAR® qualified.

Feature descriptions can be found in the [glossary](#) on pages 136–139. Complete product specifications can be found on page 157.

Downdraft Vent & Hood Liners



UXD8630DY 30" Pop-Up S
UXD8636DY 36" Pop-Up S

- Up to 600 CFM
- Dual centrifugal fan
- Vented only
- Multiple dishwasher-safe grease filters
- 4-speed slider controls



UXL5430BS S

- Convertible (recirculating or vented)
- Multiple dishwasher-safe grease filters
- 3-speed push-button controls
- Halogen lights
- Optional Recirculation kit/Charcoal filter

Hood Liners



UXL6036YS S

- Auto-On Heat Sensor
- Additional dishwasher-safe grease filter
- 3-speed slider controls
- Adjustable halogen lights
- Vented only



UXL6048YS S

- Additional dishwasher-safe grease filter
- Vented only
- 3-speed slider controls
- Adjustable halogen lights

Step-up features highlighted by yellow bar

Feature descriptions can be found in the [glossary](#) on pages 136–139. Complete product specifications can be found on pages 158–159.

Accessories



Gourmet Griddle (4396096RB)

An easy-to-clean, non-stick griddle for electric coil, gas and ceramic glass ranges. Place over two elements or burners for great grilled sandwiches or other dishes.



Cooktop Care Kit (31605)

Includes everything you need to keep your cooktop clean and protected: a bottle of Cooktop Cleaner, a bottle of Cooktop Protectant and applicator cleaning pads.



Baking Stone (4378577)

This baking stone evenly distributes heat and moisture for lighter, crispier food. Suitable for use in regular, convection and microwave ovens.



All-Purpose Appliance Cleaner (31682)

Cuts through grease and other spills on most appliance and countertop surfaces. The hint of citrus leaves a refreshing scent behind.



Gas Grate & Grill Cleaner (31617A)

This gentle cleaning formula works great on any porcelain, glass or chrome surface on your gas cooktop.



Microwave Crisper Pan (W10187336A)

Prepare crisp bacon, potatoes or pizza in the microwave with this pan.



Stainless Steel Cleaner & Polish (31462A)

Remove grease, grime and fingerprints from your stainless appliances with this specially formulated cleaner.



30" Range Oven Rack (W10273852A)

Replace a standard cooking rack in Whirlpool® double oven ranges with this roll-out rack. Its easy-gliding design makes it simple to retrieve dishes from a hot oven.



Touch-Up Paint

White: 72017
Black: 72032
Biscuit: 4392899
Universal Silver: 8212473

Touch up appliance exteriors with this 0.6 fl. oz. bottle of touch-up paint. Includes applicator brush.



Heavy Duty Sliding Rack

30" Wall Ovens: W10282973A
27" Wall Ovens: W10282974A

Heavy Duty Sliding Rack with handle

30" Wall Ovens: W10282971A
27" Wall Ovens: W10282972A

Offers enough strength to support two 16-lb turkeys.



Microwave Steamer (8205262RB)

Works in tandem with the Steaming function to conveniently Steam foods such as rice, vegetables and fish with fresh, pleasing results.

Accessories

Countertop Microwave Accessories

MODEL	WMC30516A
30" Trim Kit*	White - MK2160AW Black - MK2160AB Stainless - MK2160AS
27" Trim Kit*	White - MK2167AW Black - MK2167AB Stainless - MK2167AS

Range/Oven Accessories

FILLER KIT	SLIDE-IN/ DROP-IN RANGE	DROP-IN RANGE 6" BACKSPLASH	36" MHC OPENING
White	FILL52WHT	UXA9107AAW	8171336
Black	FILL52BLK	UXA9107AAB	8171337
Biscuit	FILL52BIS	UXA9107AAQ	8171338
Stainless	—	JXA912AAP	8171339

MODEL	GY397LXU	GY399LXU	GW397LXU	GW399LXU
Side Panel (White)	UXA1100AAW	UXA1100AAW	UXA1100AAW	UXA1100AAW
Side Panel (Black)	UXA1100AAB	UXA1100AAB	UXA1100AAB	UXA1100AAB
Side Panel (Biscuit)	UXA1100AAQ	UXA1100AAQ	UXA1100AAQ	UXA1100AAQ
Side Panel (Stainless)	UXA1100AAS	UXA1100AAS	UXA1100AAS	UXA1100AAS

MODEL	WMC30516A
Trim Kit cutout dimensions (30")	15 1/4" (H) x 28 1/2" (W) x 18 1/2" (D)
Trim Kit cutout dimensions (27")	15 1/4" (H) x 25 1/2" (W) x 18 1/2" (D)

Microwave Hood Combination Accessories

AVAILABLE ACCESSORY	
Charcoal filters	W10120840A 8206230A
Grease filters	W10208631 W10181505 W10120839A

Wall Oven Accessories

MODEL	WOS51EC0/7A WOS51EC0/7A	WOS92EC0/7A WOS92EC0/7A	WOD51EC0/7A WOD51EC0/7A	WOD93EC0/7A WOD93EC0/7A	WOC54EC0/7A WOC54EC0/7A	WOC95EC0A
Side trim cover (left side)	W10344481A	W10344481A	W10327369A	W10327369A	W10344483A	W10344483A
Side trim cover (right side)	W10344480A	W10344480A	W10327368A	W10327368A	W10344482A	W10344482A
FIT system kit (30" model)	Included	Included	Included	Included	W10495945	W10495945
FIT system kit (27" model)	Included	Included	Included	Included	W10495945	N/A

Hood & Vent Accessories

UNDER CABINET ACCESSORY**	
Charcoal Kit	W10355450
7" Damper	W10355451
Power Cord	W10355452

MODEL	UXT4030AY UXT4036AY	UXT4230AY UXT4236AY	UXT5230AY UXT5236AY	UXT5530AA UXT5536AA	GXW6530DX GXW6536DX	GXI6536DX
Recirculation kit (30")	—	White - 4378581 Black - 4378581 Stainless - 4378581	White - 49001194 Black - 49001180 Stainless - 49001196	White - Included Black - Included Stainless - Included	Stainless - W10294733	—
Recirculation kit (36")	—	White - 4378581 Black - 4378581 Stainless - 4378581	White - 49001191 Black - 49001179 Stainless - 49001193	White - Included Black - Included Stainless - Included	Stainless - W10294733	Stainless - W10294734
Charcoal filters (30")	W10355450	W10355450	W10369358	W10272068	W10294730	—
Charcoal filters (36")	W10355450	W10355450	W10386873	W10272068	W10294730	W10294730
Chimney extension kit	—	—	—	—	W10294735	W10272078
Black top trim kit	—	—	—	—	W10355450	W10355450

To acquire pricing information, order Whirlpool® cooking accessories and determine delivery time, visit whirlpool.com/accessories or call 1-800-462-3819.

*Trim kit not available for compact model WMC10007A.
**Accessories listed here are compatible with models UXT4030/36AY, UXT4230/36AY and UXT5230/36AY.

Glossary

AccuBake® temperature management system

Achieve uniform baking results every time with the AccuBake® temperature management system. A built-in sensor monitors oven temperature and controls the cooking elements to deliver consistent, delicious results every time.

AccuSimmer® burner/element

Delivers precise temperature control that is perfect for melting chocolate or simmering sauces. The AccuSimmer® Plus element offers more control and reaches your cooktop’s lowest temperatures.

AccuSimmer® cycle

Quickly boils liquids in the microwave, then automatically reduces the heat to a delicate simmer to avoid splatters.

AccuWave® power system

Evenly cooks, defrosts, reheats, softens and melts with constant, gentle heat. Thaw chicken without cooking the edges and reheat sauce without splatters.

Add 30 Seconds option

Quickly set the microwave to cook for 30 seconds at 100% power by pressing this button. Or, press it to add 30 seconds to a manual setting that is already in progress.

Adjustable split rack

Remove the rack insert to make room for large items like a turkey or attach it to make a full rack. The insert can also be used on the counter as a cooling rack.

Adjustable time self-cleaning system

Allows for adjustment of the self-clean time in 15-minute intervals, according to your needs.

AquaLift® self-clean technology

Delivers easy and odor-free oven cleaning in only 50 minutes.* Our most energy-efficient self-cleaning cycle available** uses water and low-heat to release baked-on foods from the bottom of the oven. When the cleaning cycle is complete, soils and excess water can be easily removed with a dry towel.

Auto Adapt fan

Automatically adjusts fan speed on microwave hood combinations by sensing cooktop heat.

Bridge element

Increases cooking options via a 700-watt bridge that connects two heating elements. Evenly heat large or oblong pans more easily on the cooktop.

Center griddle

Allows you to warm tortillas, make pancakes or sear fish with a built-in, center griddle.

CleanRelease® non-stick interior

Reduces cleanup effort because of the non-stick interior—an industry first. No special cleaning solutions are required.

Control Bake

This baking mode keeps the broil element turned off, preventing the tops of your food from overcooking, so pies and turkey come out just right.

Control lock

Disables the control panel to avoid unintended use or other changes to your cooking settings.

Convection Conversion

Removes the guesswork from preparing your favorite dishes by automatically converting standard times and temperatures to the convection equivalent.

Convertible ventilation system

Provides added installation flexibility by venting odors outside or recirculating them, depending upon your preference.

Crisper pan with handle

Provides the ideal cookware for pan-frying foods like bacon or potatoes in the microwave. The patented, non-stick design makes cleanup easy.

Custom Broil

Allows you to set your preferred broiling temperature in 5-degree increments. High heat is best for grilling meats, while low heat is ideal for delicate tasks.

Delay Bake

Lets you program the oven to begin cooking at a pre-set time. Prepare food for baking when it’s most convenient for you and have dinner ready according to your schedule.

Downdraft vent system

Pulls steam, smoke and odors downward and outside to help clear kitchen air. Conveniently built into select cooktops.

Dual and Triple radiant elements

Provides the space-saving advantage of having two or three elements in one to handle various sizes of cookware. The inner ring is perfect for simmering or quickly boiling water in small pans. The larger outer ring evenly distributes heat to larger pots and pans for better results.

EasyView™ extra-large oven window

Provides better visibility of the oven interior with an extra-large window. Monitor cooking progress without opening the door, keeping oven temperatures steady and undisturbed. Select wall ovens and freestanding ranges feature an improved EasyView™ extra-large oven window for greater visibility when cooking.

Energy Save mode

Similar to the sleep mode on a computer, the Energy Save feature uses less energy compared to ranges without Energy Save. It can be activated to turn off the display after 5 minutes of the range not being used. Press any button and the display becomes active again.

EZ-Vue™ lighting

Provides illumination above the range according to your preference with three brightness settings, including a night-light option. Bulbs change out easily when a replacement is needed.

Filter change indicator light

Informs you when it’s time to change the microwave hood combination filter so air stays fresher. No more guessing about when you need to change a filter.

FIT system

Now your wall oven can fit seamlessly into your current cabinet cutout† with this flexible installation system. It provides various options that are designed to effortlessly suit your decor.

Flex Power™ burner

A 17,000-BTU Flex Power™ burner generates the high heat needed for rapid boiling and searing and provides uniform cooking at lower temperatures for your most delicate dishes, making this our most flexible burner ever.

Frameless door design

Permits easy exterior cleaning with a flat, frameless panel. No nooks or crannies to catch crumbs.

Full-width, cast-iron grates

Offers a smooth design for easy cleaning by hand or in the dishwasher. The grates cover the entire cooktop surface, creating the flexibility to place pots and pans anywhere, while the smooth satin finish resists wear and tear.

Grill rack

Provides the ideal setup when using the grill function of a SpeedCook oven or microwave hood combination, allowing you to place food closer to the grill element for faster cooking. Steaks look and taste as if they were cooked under the oven broiler but are ready in less time.

Glossary

Hidden bake element

Simplifies cleanup with the bake element hidden beneath the oven floor, leaving a smooth interior surface that is easy to wipe clean.

High-speed coil element

Heats up quickly to provide high temperatures for boiling and frying. Chrome drip pans below catch spills for easy cleanup.

Hot surface indicator

Illuminates when the cooktop surface is still hot to the touch—even after the heating element has been turned off.

Induction technology

Transfers energy directly into any magnetic cookware for faster, more efficient cooking. Whirlpool brand’s induction technology transfers heat directly to cookware using 25% less energy than traditional ceramic glass cooktops and 58% less energy than traditional gas cooktops.††

Infinite heat controls

Allow for smooth movement of temperature settings, from low to high. Adjust the heat up or down according to your cooking needs.

Kids Menu

Cooks a variety of child-friendly food with preprogrammed cycles that are activated by the simple push of a button. With menu selections like hot dogs and chicken nuggets, children can easily prepare their own pre-game dinners or after-school snacks.

LP Convertible

Can be converted from natural gas to a liquid petroleum fuel source.

Max Capacity recessed rack

Makes room for large items and helps keep food in place while baking.

Melt/Soften cycles

Gently melts foods such as chocolate without cooking (Melt Cycle); gently softens food such as butter without melting (Soften Cycle).

Microwave steamer

Works in tandem with the steaming function to conveniently steam foods such as rice, vegetables and fish with fresh, pleasing results.

Modular cooktop

Allows you to customize the cooking surface according to your needs with gas burners, grill modules and griddle modules.

Most Used cycle

Saves time by remembering and activating your most frequently used Velos® SpeedCook cycle with the simple press of a button.

*Based on average cleaning time of self-clean cycle with water and moderate soils. **Versus traditional self clean cycle.

†Available on 27" and 30" double and single wall ovens. See product specifications for minimum and maximum installation dimensions.

††Based on boiling 3.6 liters of water with a 9" 3,200-watt induction element compared to a traditional 9" 2,500-watt radiant element or a 12,500-BTU gas burner.

Glossary

No Drip chrome drip bowl

Keeps cooking cleanup to a minimum and keeps spills from getting under the cooking surface.

One touch bake and broil

Automatically sets the oven to 350°F when the “Bake” button is pushed and 500°F when the “Broil” button is selected.

Oval burner

An elongated central burner that can match oval-shaped pans and other longer cookware. Ideal for cooking large whole fish or other oversized dishes on the range top.

Oven Hold Warm/Warm Hold/Keep Warm

Uses low heat to keep food warm inside the oven or microwave, so you can keep completed dishes from getting cold while you work on the rest of your meal.

Pop-up downdraft vent

Retracts when not in use. Variable speed fans make adjusting the ventilation easy for every situation.

Power™ burners

Generate the high heat needed for rapid boiling, searing and frying with burners that offer up to 17,000 BTUs.

Power “On” indicator

Provides an illuminated reminder that the cooktop is turned on.

Precise Clean® system

Tracks how long it has been since the last self-clean cycle and suggests just the right cycle time, so the self-cleaning cycle only lasts as long as necessary for optimal cleaning. No harsh chemicals or cleaners are required.

Preheat countdown timer

Keeps track of how long the oven will take to reach the desired baking temperature with a display that counts down the required time or temperature.

Rapid Boil element

A more powerful radiant element brings liquids to a boil quicker and provides cooking flexibility by accommodating various sizes of cookware.

Rapid Preheat option

Preheat the oven 25% faster* with Rapid Preheat. Ideal for single rack baking, this option saves cooking time and energy.

Recessed cooktop

Provides a more aesthetically pleasing profile by lowering the level of the grates.

Sabbath mode

Overrides the oven’s automatic shut-off function, keeping it active for hours of uninterrupted cooking, making it possible to use the oven on the Sabbath without turning it on.

Schott Ceran® eco-friendly ceramic glass cooktop

This eco-friendly cooktop is manufactured without the release of hazardous metals into the earth.**

Sealed burners

Cleans up quickly after cooking is complete. No gap between the cooktop and these burners makes for a smooth surface that’s easy to clean.

Self-cleaning system (traditional)

Automatically cleans the oven according to a preprogrammed cycle. No harsh chemicals or cleaners are required.

Sensor cooking

Tracks the progress of your food and automatically adjusts the cooking time as needed to deliver optimal results

SpeedCook technology

Cuts cooking time by up to 47% compared to traditional ovens. Microwave technology works with halogen and quartz light energy to grill steaks and bake brownies with real oven results.

SpillGuard™ cooktop

Helps contain messes and makes cleanup easier with the raised-edge design.

Split rack

Remove the rack insert to make room for large or tall items, or attach it to make a full rack.

Staged cooking

Allows you to custom program multiple power levels and cooking durations without keeping watch over the microwave. Ideal for dishes requiring temperature changes mid-cooking, like frozen entrees.

SteamClean option

Clean up every day light spills using heat and only 1-1/4 cups of water—no harsh chemicals or cleaners needed.

Steam cooking

Conveniently steams foods such as rice, vegetables and fish in conjunction with the patented microwave steamer.

Glossary

Tap Touch controls

Provide a sleek, sophisticated look that is easy to clean. Cooktop controls can be set with a simple touch.

TimeSavor™ convection

Uses a fan in the back of the oven to distribute hot air more efficiently to seal in flavor and juices.

TimeSavor™ Plus true convection

Uses a fan plus a third heating element in the oven or microwave to distribute hot air more efficiently and seal in flavor and juices. Select microwaves use a rear fan to also cut roasting time compared to traditional thermal-bake ovens.

TimeSavor™ Ultra true convection cooking

Achieve exceptional results faster on every rack with TimeSavor™ Ultra true convection. This new convection cooking system offers greater and more efficient air flow so the oven is filled with even heat.

Touch screen controls

Features dozens of step-by-step directions on a digital display for simple, accurate cooking in the microwave.

TruCapture® ventilation system

Removes cooktop smoke, steam and odors from the front two burners with a powerful 4-speed fan and unique, sloped design that vents out the top instead of the front of the unit. Whirlpool brand’s most efficient ventilation system.

Universal Silver finish

Resists fingerprints and cleans easily. The Universal Silver painted finish is an affordable alternative to stainless steel.

Velos® SpeedCook oven

Microwave hood combination oven that grills, bakes, steams, microwaves and vents, featuring SpeedCook technology as well as the TruCapture® ventilation system.

Warming drawer

Keeps food warm in a separate, heated drawer. Multiple temperature settings provide flexibility and help ensure that food done ahead of schedule doesn’t get cold before the entire meal is ready to serve.

Warm Zone element

Prevents food from cooling while the rest of the meal is being prepared. This low-powered (20–100 watt) fifth element provides added flexibility and convenience.

Washable filter

Dishwasher-safe filters trap unwanted grease and odors and wash easily for re-use.

*Single rack baking with **Rapid Preheat** option versus three-rack without option. **Eco-friendly designation does not apply to Pure White and Pure Biscuit Schott Ceran® cooktops.

Freestanding Electric Ranges

SPECIFICATIONS AND DIMENSIONS

MODEL	WHIRLPOOL®					
	WFC110M0A	WFC130M0A	WFC340S0A	WFC310S0A	WFE320M0A	WFE330W0A
New 2012 model	-	-	-	-	-	-
Capacity (cu. ft.)	4.8	4.8	4.8	4.8	4.8	5.3
Recommended MHC	WMH31017A	WMH31017A	WMH31017A	WMH31017A	WMH31017A	WMH31017A
Oven controls	Knob	Electronic	Knob	Electronic	Electronic	Electronic
Metal handle*	-	-	♦	-	♦	-
ADA compliant**	-	-	♦	-	-	-
OVEN FEATURES						
AccuBake® temperature management system	-	-	-	♦	-	♦
Traditional self-cleaning system	-	-	♦	-	-	-
SteamClean option	-	-	-	-	-	♦
Hidden bake element	-	-	-	-	-	♦
Delay Bake	-	-	-	♦	-	-
Keep Warm	-	-	-	♦	-	♦
Custom Broil	-	-	-	-	-	-
Sabbath Mode	-	♦	-	♦	-	-
Control lock	-	♦	-	♦	-	-
Clock and timer display color	-	Blue	-	Blue	Blue	Blue
Oven light	-	♦	-	-	-	-
Total adjustable racks	2	2	2	2	2	2
Oven window	-	Standard	Large	Large	Large	Large
Lower drawer	Storage	Storage	Storage	Storage	Storage	Storage
COOKTOP FEATURES						
Eco-friendly Schott Ceran® cooktop	-	-	-	-	♦	-
Upswept porcelain SpillGuard® cooktop	-	-	-	-	-	-
Element type	Coil	Coil	Coil	High-speed coils	Radiant	Radiant
Left rear element	6" 1,250-watt	6" 1,250-watt	6" 1,250-watt	6" 1,500-watt high-speed	6" 1,200-watt	6" 1,200-watt
Right rear element	8" 2,100-watt	8" 2,100-watt	8" 2,100-watt	8" 2,600-watt high-speed	6" 1,200-watt	8" 1,800-watt
Left front element	8" 2,100-watt	8" 2,100-watt	8" 2,100-watt	8" 2,600-watt high-speed	9" 3,000-watt dual	12" 3,000-watt
Right front element	6" 1,250-watt	6" 1,250-watt	6" 1,250-watt	6" 1,500-watt high-speed	9" 2,500-watt	6" 1,200-watt
DIMENSIONS AND COLORS						
Cutout height (A)	36"	36"	36"	36"	36"	36"
Cutout width (B)	30"	30"	30"	30"	30"	30"
Cutout depth (C)	24"	24"	24"	24"	24"	24"
Overall height (D)	46 1/8"	46 1/8"	46 1/8"	46 1/8"	46 1/8"	46 1/8"
Height to maintop (E)	36"	36"	36"	36"	36"	36"
Overall width (F)	29 3/4"	29 3/4"	29 3/4"	29 3/4"	29 3/4"	29 3/4"
Overall depth (G)	27 1/4"	27 1/4"	27 1/4"	27 1/4"	27 1/4"	27 1/4"
Depth without handle	25 1/8"	25 1/8"	25 1/8"	25 1/8"	25 1/8"	25 1/8"
Depth with door open 90°	46 1/8"	46 1/8"	46 1/8"	46 1/8"	46 1/8"	46 1/8"
Available colors	W	W B	W B S	W B T S	W B S	W B S

Bold type indicates a step-up feature

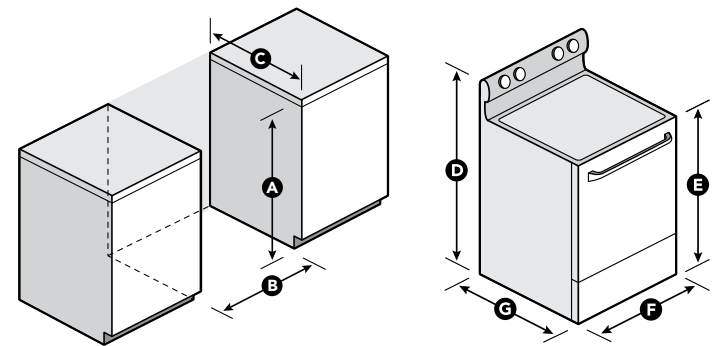

DIMENSIONS ARE SHOWN FOR PLANNING PURPOSES ONLY. For complete information, see Installation Instructions packed with product.

*Available on Stainless Steel models only. **Model meets applicable ADA requirements and must be installed in compliance with the current ADA Standards.

Freestanding Electric Ranges

SPECIFICATIONS AND DIMENSIONS

MODEL	WHIRLPOOL®			WHIRLPOOL GOLD®		
	WFE510S0A	WFE520C0A	WFE540H0A	WFE710H0A	WFE720H0A	WFI910H0A INDUCTION
New 2012 model	-	-	-	-	-	-
Capacity (cu. ft.)	4.8	5.3	6.2	6.2	6.2	6.2
Recommended MHC	WMH32517A	WMH53520A	WMH53520A	WMH53520A	WMH53520A	WMH53520A
Oven controls	Electronic	Electronic	Electronic	Electronic	Electronic	Tap Touch†
Metal handle*	-	-	-	-	-	-
OVEN FEATURES						
AccuBake® temperature management system	-	-	-	-	-	-
NEW! AquaLift® self-clean technology	-	-	♦	-	-	-
Traditional self-cleaning system	♦	-	-	-	-	-
SteamClean option	-	♦	-	-	-	-
Hidden bake element	-	-	with thermal vents	with thermal vents	with thermal vents	with thermal vents
TimeSaver™ Plus true convection	-	-	-	♦	-	-
TimeSaver™ convection cooking	-	-	♦	-	-	-
Convection Conversion	-	-	-	♦	-	-
Energy Save mode	-	-	♦	-	-	-
Rapid Preheat	-	-	-	♦	-	-
Delay Bake	-	♦	-	-	-	-
Keep Warm	-	♦	-	-	-	-
Custom Broil	-	-	-	-	-	-
Sabbath Mode	-	-	-	-	-	-
Control lock	-	-	-	-	-	-
Clock and timer display color	Blue	Blue	Blue	Blue	Blue	Blue
Oven light	-	-	-	-	-	-
Total adjustable racks	2	2	2	3	3	3
Max Capacity recessed rack	-	-	♦	-	-	-
Adjustable split rack	-	-	-	♦	-	-
Oven window	Large	Large	New EasyView™ extra-large	New EasyView™ extra-large	New EasyView™ extra-large	New EasyView™ extra-large
Lower drawer	Storage	Storage	Storage	Storage	High/Med/Low warming with handle	High/Med/Low warming with handle
COOKTOP FEATURES						
Eco-friendly Schott Ceran® cooktop	-	-	-	-	-	-
Element type	Radiant	Radiant	Radiant	Radiant	Radiant	Induction
Left rear element	6" 1,200-watt	6" 1,200-watt	6" 1,200-watt	6" 300/1,300-watt AccuSimmer®	6" 300/1,300-watt AccuSimmer®	9" 3,200-watt Boost
Right rear element	6" 1,200-watt	6" 1,200-watt	6" 1,200-watt	6" 1,200-watt	6" 1,200-watt	11" 3,700-watt Boost
Left front element	9" 3,000-watt dual	12" 3,000-watt dual	12" 3,000-watt dual	12" 3,000-watt dual	12" 3,000-watt triple	6" 1,800-watt Boost
Right front element	9" 2,500-watt	10" 2,500-watt	9" 3,000-watt dual	3,000-watt dual	10" 3,200-watt Rapid Boil	6" 1,800-watt Boost
Center rear element	-	6" 100-watt Warm Zone	6" 100-watt Warm Zone	6" 100-watt Warm Zone	6" 100-watt Warm Zone	-
DIMENSIONS AND COLORS						
Cutout height (A)	36"	36"	36"	36"	36"	36"
Cutout width (B)	30"	30"	30"	30"	30"	30"
Cutout depth (C)	24"	24"	24"	24"	24"	24"
Overall height (D)	46 1/8"	46 1/8"	46 1/8"	46 1/8"	46 1/8"	46 1/8"
Height to maintop (E)	36"	36"	36"	36"	36"	36"
Overall width (F)	29 3/4"	29 3/4"	29 3/4"	29 3/4"	29 3/4"	29 3/4"
Overall depth (G)	27 1/4"	27 1/4"	27 1/4"	27 1/4"	27 1/4"	27 1/4"
Depth without handle	25 1/8"	25 1/8"	25 1/8"	25 1/8"	25 1/8"	25 1/8"
Depth with door open 90°	46 1/8"	46 1/8"	47 1/8"	47 1/8"	47 1/8"	47 1/8"
Available colors	W B T D S	W B S	W B S H E	S H E	S	S

Bold type indicates a step-up feature

*Available on Stainless Steel models only. †Cooktop only.

Freestanding Gas Ranges

SPECIFICATIONS AND DIMENSIONS

MODEL	WHIRLPOOL®			
	WFG110AV	WFG111SV	WFG114SW	WFG231LV
Capacity (cu. ft.)	4.4	4.4	4.4	4.4
Recommended MHC	WMH31017A	WMH31017A	WMH31017A	WMH31017A
Oven controls	Knob	Knob	Electronic	Electronic
OVEN FEATURES				
Custom Broil			♦	.
Clock and timer display color			Blue green	Blue green
Oven light			♦	.
Total adjustable racks	2	2	2	2
Oven window		Standard	Standard	Large
Lower drawer	Broiler	Broiler	Broiler	Broiler
LP Convertible (kit included)
COOKTOP FEATURES				
Included griddle				Center
Burner grates	Steel	Steel	Cast-iron	Cast-iron
Left rear burner	9,500 BTU	9,500 BTU	9,500 BTU	7,000 BTU
Right rear burner	9,500 BTU	9,500 BTU	9,500 BTU	7,000 BTU
Left front burner	9,500 BTU	9,500 BTU	11,500 BTU	8,000 BTU
Right front burner	9,500 BTU	9,500 BTU	9,500 BTU	7,000 BTU
Center burner				7,500 BTU Oval
DIMENSIONS AND COLORS				
Cutout height (A)	36"	36"	36"	36"
Cutout width (B)	30"	30"	30"	30"
Cutout depth (C)	24"	24"	24"	24"
Overall height (D)	46 1/4"	46 1/4"	46 1/4"	46 1/4"
Height to maintop (E)	36"	36"	36"	36"
Overall width (F)	29 3/4"	29 3/4"	29 3/4"	29 3/4"
Overall depth (G)	26 1/4"	26 1/4"	26 1/4"	25 1/4"
Depth without handle	24 1/4"	24 1/4"	24 1/4"	24 1/4"
Depth with door open 90°	42 1/4"	42 1/4"	42 1/4"	42 1/4"
Available colors	Q	Q	Q B T	Q B S

Bold type indicates a step-up feature

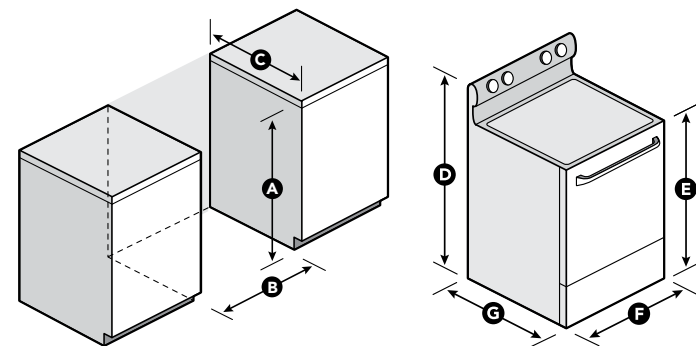

DIMENSIONS ARE SHOWN FOR PLANNING PURPOSES ONLY. For complete information, see Installation Instructions packed with product.

Freestanding Gas Ranges

SPECIFICATIONS AND DIMENSIONS

MODEL	WHIRLPOOL®		WHIRLPOOL GOLD®		
	WFG510S0A	WFG520S0A	WFG540H0A	WFG710H0A	WFG720H0A
New 2012 model
Capacity (cu. ft.)	5.0	5.0	5.8	5.8	5.8
Recommended MHC	WMH32517A	WMH53520A	WMH53520A	WMH53520A	WMH53520A
Oven controls	Electronic	Electronic	Electronic	Electronic	Electronic
Metal handle*	♦
OVEN FEATURES					
AccuBake® temperature management system	♦
NEW! AquaLift® self-clean technology			♦	.	.
Traditional self-cleaning system	♦
TimeSaver™ Plus true convection					♦
TimeSaver™ convection			♦	.	.
Convection Conversion				♦	.
Energy Save			♦	.	.
Rapid Preheat				♦	.
Delay Bake	♦
Keep Warm	♦
Custom Broil
Sabbath Mode	♦
Control lock	♦
Clock and timer display color	Blue	Blue	Blue	Blue	Blue
Oven light
Total adjustable racks	2	2	2	3	3
Max Capacity recessed rack			♦	.	.
Adjustable split rack				♦	.
Oven window	Large	Large	New EasyView™ extra-large	New EasyView™ extra-large	New EasyView™ extra-large
Lower drawer	Storage	Storage	Storage	Storage	High/Med/Low warming with handle
LP Convertible (kit included)
COOKTOP FEATURES					
Included griddle				Side integrated	Side integrated
Recessed cooktop	♦
Burner grates	Satin-finish, cast-iron	Full-width, satin-finish, cast-iron	Full-width, satin-finish, cast-iron	Full-width, satin-finish, cast-iron	Full-width, satin-finish, cast-iron
Left rear burner	9,500 BTU	9,500 BTU	9,500 BTU	9,500 BTU	9,500 BTU
Right rear burner	5,000 BTU AccuSimmer®	5,000 BTU AccuSimmer®	5,000 BTU AccuSimmer®	5,000 BTU AccuSimmer®	5,000 BTU AccuSimmer®
Left front burner	13,500 BTU Power™	15,000 BTU Power™	17,000 BTU Power™	17,000 BTU Power™	17,000 BTU Power™
Right front burner	9,500 BTU	15,000 BTU Power™	15,000 BTU Power™	15,000 BTU Power™	15,000 BTU Power™
Center burner			8,000 BTU Middle	8,000 BTU Middle	8,000 BTU Middle
DIMENSIONS AND COLORS					
Cutout height (A)	36"	36"	36"	36"	36"
Cutout width (B)	30"	30"	30"	30"	30"
Cutout depth (C)	24"	24"	24"	24"	24"
Overall height (D)	46 1/4"	46 1/4"	46 1/4"	46 1/4"	46 1/4"
Height to maintop (E)	36"	36"	36"	36"	36"
Overall width (F)	29 3/4"	29 3/4"	29 3/4"	29 3/4"	29 3/4"
Overall depth (G)	27 1/4"	27 1/4"	27 1/4"	27 1/4"	27 1/4"
Depth without handle	25 1/4"	25 1/4"	25 1/4"	25 1/4"	25 1/4"
Depth with door open 90°	46 1/4"	46 1/4"	47 1/4"	47 1/4"	47 1/4"
Available colors	W B T D S	W B S	W B S H E	S H E	S

Bold type indicates a step-up feature

*Available on Stainless Steel models only.

Freestanding Double Oven Ranges

SPECIFICATIONS AND DIMENSIONS

MODEL	WHIRLPOOL GOLD®			
	GGE388LX ELECTRIC	GGE390LX ELECTRIC	GGG388LX GAS	GGG390LX GAS
Oven capacity (cu. ft.)	2.5 Upper 4.2 Lower	2.5 Upper 4.2 Lower	2.1 Upper 3.9 Lower	2.1 Upper 3.9 Lower
Total capacity (cu. ft.)	6.7	6.7	6.0	6.0
Recommended MHC	GMH3204XV	GMH3204XV	GMH3204XV	GMH3204XV
Electronic oven controls	-	-	-	-
CONVENIENCE FEATURES (BOTH OVENS)				
AccuBake® temperature management system	-	-	-	-
Precise Clean™ self-cleaning system	-	-	-	-
SteamClean option	-	◆	-	-
Hidden bake element	-	◆	-	-
Energy Save mode	-	-	-	-
Delay Bake	-	-	-	-
Oven Hold Warm	-	-	-	-
Sabbath Mode	-	-	-	-
Control lock	-	-	-	-
Clock and timer display color	Blue	Blue	Blue	Blue
Automatic oven light	-	-	-	-
LP Convertible	-	-	-	-
UPPER OVEN FEATURES				
Custom Broil	-	-	-	-
Adjustable rack	1	1	1	1
Rack positions	2	2	2	2
LOWER OVEN FEATURES				
TimeSaver™ Plus true convection	-	◆	-	-
TimeSaver™ convection	-	-	-	◆
Custom Broil	-	-	-	-
Adjustable racks	2	2	2	2
Rack positions	5	5	5	5
EasyView™ extra-large oven window	-	-	-	-
COOKTOP FEATURES				
Eco-friendly Schott Ceran® cooktop	-	-	-	-
Upswept SpillGuard™ cooktop	-	-	-	-
Recessed cooktop	-	-	◆	-
Full-width, satin-finish cast-iron grates	-	-	◆	-
Left rear element/burner	6"	6"	5,000 BTU AccuSimmer®	5,000 BTU AccuSimmer®
Right rear element/burner	6"	6"	9,200 BTU	5,000 BTU AccuSimmer®
Left front element/burner	9"/6" dual	12"/9" dual	15,000 BTU Power™	16,000 BTU Power™
Right front element/burner	9"	9"/6" dual	9,200 BTU	10,000 BTU
Center element/burner	6" Warm Zone	6" Warm Zone	-	7,350 BTU Oval
DIMENSIONS AND COLORS				
Cutout height (A)	36"	36"	36"	36"
Cutout width (B)	30 1/8"	30 1/8"	30 1/8"	30 1/8"
Cutout depth (C)	24"	24"	24"	24"
Overall height (D)	47 1/4"	47 1/4"	47 1/4"	47 1/4"
Height to maintop (E)	36"	36"	36"	36"
Overall width (F)	29 1/8"	29 1/8"	29 1/8"	29 1/8"
Depth without handle (G)	26 1/4"	26 1/4"	26 1/4"	26 1/4"
Depth with handle	27 1/4"	27 1/4"	27 1/4"	27 1/4"
Depth with door open 90°	46"	46"	46"	46"
Available colors	Q B S	Q B S	Q B S	Q B S

Bold type indicates a step-up feature

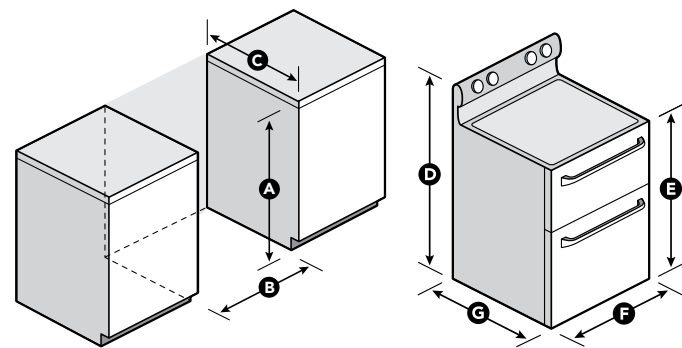

DIMENSIONS ARE SHOWN FOR PLANNING PURPOSES ONLY. For complete information, see Installation Instructions packed with product.

Slide-In Ranges

SPECIFICATIONS AND DIMENSIONS

MODEL	WHIRLPOOL®	WHIRLPOOL GOLD®			
	RY160LXT ELECTRIC	GY397LXU ELECTRIC	GY399LXU ELECTRIC	GW397LXU GAS	GW399LXU GAS
Capacity (cu. ft.)	4.3	4.5	4.5	4.5	4.5
Recommended MHC	WMH3205XV	WMH75520A	WMH76718A	WMH75520A	WMH76718A
Metal handle*	-	◆	-	-	-
OVEN FEATURES					
AccuBake® temperature management system	-	◆	-	-	-
Precise Clean™ self-cleaning system	-	-	-	-	-
Hidden bake element	-	-	◆	-	-
TimeSaver™ Plus true convection	-	-	◆	-	◆
Delay Bake	-	◆	-	-	-
Warm Hold	-	-	-	-	-
Sabbath Mode	-	-	-	-	-
Control lock	-	-	-	-	-
Clock and timer display color	Blue	Blue	Blue	Blue	Blue
Automatic oven light	-	◆	-	-	-
Raised ergonomic console	-	◆	-	-	-
Total adjustable racks	2	2	2	2	2
Adjustable split rack	-	-	◆	-	◆
Extra-large oven window	-	-	-	-	-
Storage drawer	-	-	-	-	-
Frameless door design	-	◆	-	-	-
LP Convertible	-	-	-	◆	-
COOKTOP FEATURES					
Eco-friendly Schott Ceran® cooktop	-	◆	-	-	-
Recessed cooktop	-	-	-	◆	-
Element type	Coil	Radiant	Radiant	-	-
Continuous, satin-finish, cast-iron grates	-	-	-	◆	-
Left rear element/burner	8"	9"/6" dual	9"/6" dual	5,000 BTU	5,000 BTU
Right rear element/burner	6"	6"	6"	9,200 BTU	9,200 BTU
Left front element/burner	6"	6"	6"	9,200 BTU	12,500 BTU Power™
Right front element/burner	8"	9"/6" dual	12"/9" dual	14,000 BTU Power™	16,000 BTU Power™
DIMENSIONS AND COLORS					
Cutout width (A)	30"	30"	30"	30"	30"
Cutout depth (B)	23 1/4"	23 1/4"	23 1/4"	23 1/4"	23 1/4"
Height (C)	35 1/4"	35 1/4"	35 1/4"	35 1/4"	35 1/4"
Base width (D)	29 1/4"	29 1/4"	29 1/4"	29 1/4"	29 1/4"
Depth (E)	28 1/4"	28 1/4"	28 1/4"	28 1/4"	28 1/4"
Available colors	Q B S	Q B S	Q B S	Q B S	Q B S

Bold type indicates a step-up feature

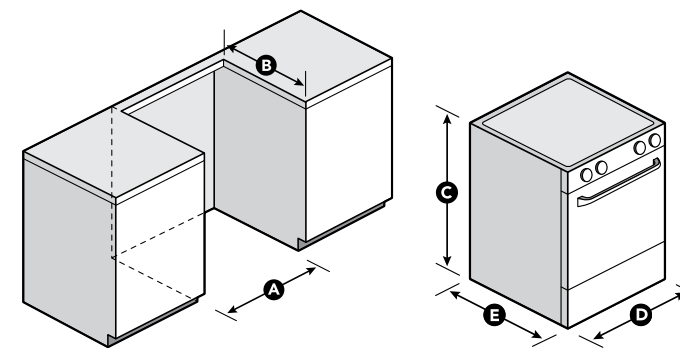

*Available on Stainless Steel models only.

Drop-In Electric Ranges

SPECIFICATIONS AND DIMENSIONS

WHIRLPOOL®		
MODEL	WDE150LV	WDE350LV
Capacity (cu. ft.)	4.5	4.5
Recommended MHC	WMH2175XV	WMH75520A
Metal handle*	-	-
OVEN FEATURES		
AccuBake® temperature management system	-	-
Self-cleaning system with Delay Clean	-	-
Delay Bake	-	-
Oven Hold Warm	-	-
Sabbath Mode	-	-
Control lock	-	-
Timer display color	Blue	Blue
Oven light	-	-
Adjustable racks	2	2
Large oven window	-	-
Frameless door design	-	-
COOKTOP FEATURES		
Eco-friendly Schott Ceran® cooktop	-	♦
Element type	Coil	Radiant
Left rear element	8"	9"/6" dual
Right rear element	6"	6"
Left front element	6"	6"
Right front element	8"	9"/6" dual
DIMENSIONS AND COLORS		
Cutout width (A)	30"	30"
Cutout depth (B)	23 1/4"	23 1/4"
Countertop height (C)	27 1/2"	27 1/2"
Height (D)	28 1/2"	28 1/2"
Base width (E)	29 1/4"	29 1/4"
Recessed depth (F)	26 1/4"	26 1/4"
Available colors	Q B S	Q B S

Bold type indicates a step-up feature

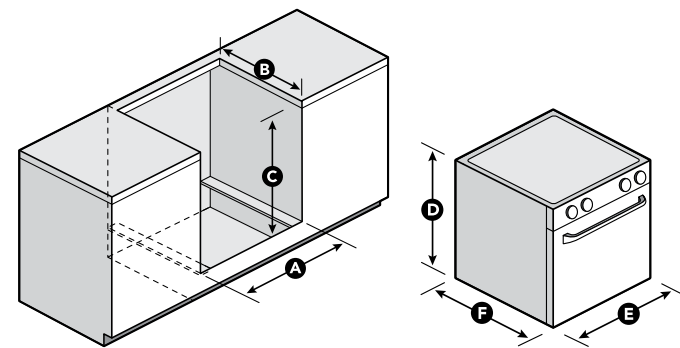

*Available on Stainless Steel models only.

DIMENSIONS ARE SHOWN FOR PLANNING PURPOSES ONLY. For complete information, see Installation Instructions packed with product.

Single Wall Ovens

SPECIFICATIONS AND DIMENSIONS

WHIRLPOOL®		WHIRLPOOL GOLD®	
MODEL	RBS245PR	WOS51EC0A	WOS92EC0A
New 2012 model	-	-	-
Size	24"	30"	30"
Also available in 27"	-	WOS51EC7A	WOS92EC7A
Capacity (cu. ft.)	3.1	5.0 / 4.3	5.0 / 4.3
Recommended cooktops	W5CE3024X W5CG3024X	W5CE3024X W5CG3024X	G9CE3065X G7CG3064X
Metal handle	-	♦	-
OVEN FEATURES			
AccuBake® temperature management system	-	-	-
Precise Clean™ self-cleaning system	-	♦	-
Self-cleaning system	-	-	-
SteamClean option	-	♦	-
Hidden bake element	-	♦	-
NEW! TimeSaver™ Ultra true convection	-	-	♦
Convection Conversion	-	-	♦
Rapid Preheat	-	-	♦
Preheat countdown	Timer	Temperature	Temperature
Delay Bake	-	-	-
Hold Warm	-	♦	-
Custom Broil	-	♦	-
Closed door broiling	-	-	-
Sabbath Mode	-	♦	-
Control lock	-	-	-
Illuminated display (two-color)	-	-	-
Oven light	Incandescent	Incandescent	Incandescent
Total adjustable racks	2	2	3
Oven window	Large	New EasyView™ extra-large	New EasyView™ extra-large
NEW! FIT system	-	♦	-
Approved for under-the-counter installation	-	-	-
GENERAL INFORMATION			
Bake element watts at 240/208 volts	2000W/1500W	2800W/2427W	2800W/2427W
Broil element watts at 240/208 volts	3000W/2250W	3600W/3120W	3600W/3120W
Convection element watts at 240/208 volts	-	-	2500W/2167W
Circuit amperage	30 Amps	30 Amps	30 Amps
Total connected load at 240 volts	5 kW	3.7 kW	3.7 kW
Total connected load at 208 volts	3.8 kW	2.8 kW	2.8 kW
24" Oven cavity size (H x W x D)	16" x 19" x 17 1/4"	-	-
27" Oven cavity size (H x W x D)	-	18" x 22" x 19"	18" x 22" x 19"
30" Oven cavity size (H x W x D)	-	18" x 25" x 19"	18" x 25" x 19"
DIMENSIONS AND COLORS			
Cutout height (A)	27 1/4"	26 5/8"-29 1/8"	26 5/8"-29 1/8"
Cutout width (B)	22 1/2"	28 1/2" / 25 1/2"	28 1/2" / 25 1/2"
Cutout depth (C)	23 1/4"	24"	24"
Overall height (D)	29"	28 3/4"	28 3/4"
Overall width (E)	23 3/4"	30" / 27"	30" / 27"
Overall depth (F)	26"	26 3/4"	26 3/4"
Available colors (24" and 30" models)	Q B T S	W B T S	W B S H E
Available colors (27" models)	-	W B S	W B S

Bold type indicates a step-up feature

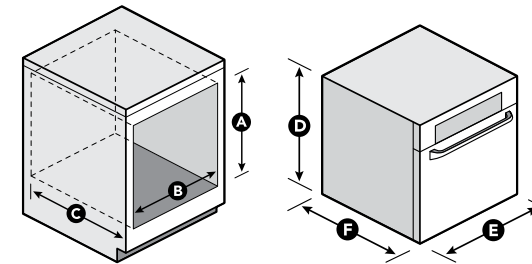

Double Wall Ovens

SPECIFICATIONS AND DIMENSIONS

MODEL	WHIRLPOOL®		WHIRLPOOL GOLD®
	RBD245PR	WOD51EC0A	WOD93EC0A
New 2012 model			
Size	24"	30"	30"
Also available in 27"		WOD51EC7A	WOD93EC7A
Upper oven capacity (cu. ft.)	3.1	5.0 / 4.3	5.0 / 4.3
Lower oven capacity (cu. ft.)	3.1	5.0 / 4.3	5.0 / 4.3
Recommended cooktops	W5CE3024X W5CG3024X	W5CE3024X W5CG3024X	G9CE3074X G7CG3064X
Metal handles		♦	
OVEN FEATURES			
AccuBake® temperature management system			
Precise Clean™ self-cleaning system		♦	
Self-cleaning system	Upper only		
SteamClean option		♦	
Hidden bake element		♦	
NEW! TimeSavor™ Ultra true convection			Upper only
Convection Conversion			Upper only
Rapid Preheat			♦
Preheat countdown	Timer	Temperature	Temperature
Delay Bake			
Hold Warm		♦	
Custom Broil		♦	
Closed door broiling			
Sabbath Mode		♦	
Control lock			
Illuminated display (two-color)			
Oven lights	Incandescent	Incandescent	Incandescent
Total adjustable racks	2 Upper / 2 Lower	2 Upper / 2 Lower	3 Upper / 2 Lower
Oven window	Large	New EasyView™ extra-large	New EasyView™ extra-large
NEW! FIT system		♦	
GENERAL INFORMATION			
Bake element watts at 240/208 volts	2000W/1500W	2800W/2427W	2800W/2427W
Broil element watts at 240/208 volts	3000W/2250W	3600W/3120W	3600W/3120W
Convection element watts at 240/208 volts		2500W/2167W	2500W/2167W
Circuit amperage	40 Amps	40 Amps	40 Amps
Total connected load at 240 volts	8 kW	7.4 kW	7.4 kW
Total connected load at 208 volts	6 kW	5.6 kW	5.6 kW
24" Oven cavity size (H x W x D)	16" x 19" x 17 ³ / ₄ "		
27" Oven cavity size (H x W x D)		18" x 22" x 19"	18" x 22" x 19"
30" Oven cavity size (H x W x D)		18" x 25" x 19"	18" x 25" x 19"
DIMENSIONS AND COLORS			
Cutout height (A)	49 1/4"	48 1/4"–52 1/4"	48 1/4"–52 1/4"
Cutout width (B)	22 1/2"	28 1/2" / 25 1/2"	28 1/2" / 25 1/2"
Cutout depth (C)	23 1/4"	24"	24"
Overall height (D)	51"	51 7/8"	51 7/8"
Overall width (E)	23 3/4"	30" / 27"	30" / 27"
Overall depth (F)	26"	26 3/4"	26 3/4"
Available colors (24" and 30" models)	Q B T S	W B T S	W B S H E
Available colors (27" models)		W B S	W B S

Bold type indicates a step-up feature

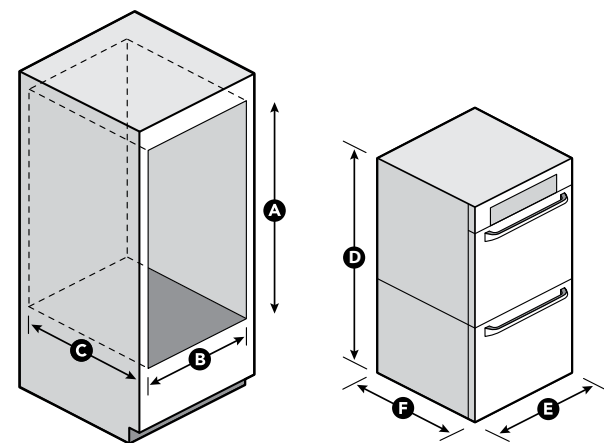

DIMENSIONS ARE SHOWN FOR PLANNING PURPOSES ONLY. For complete information, see Installation Instructions packed with product.

Combination Microwave Wall Ovens

SPECIFICATIONS AND DIMENSIONS

MODEL	WHIRLPOOL®	WHIRLPOOL GOLD®
	WOC54EC0A	WOC95EC0A
New 2012 model		
Size	30"	30"
Also available in 27"	WOC54EC7A	
Upper microwave oven capacity (cu. ft.)	1.4	1.4
Lower oven capacity (cu. ft.)	5.0 / 4.3	5.0
Recommended cooktops	W5CE3024X W5CG3024X	G9CE3074X G7CG3064X
Metal handles		
UPPER MICROWAVE OVEN FEATURES		
Sensor microwave with drop-down door		
Steam cooking	8205262RB	8205262RB
Power (watts)	900	900
Stainless steel interior		
Turntable diameter	14 1/4"	14 1/4"
OVEN FEATURES		
AccuBake® temperature management system		
Precise Clean™ self-cleaning system		
SteamClean option		
Hidden bake element		
NEW! TimeSavor™ Ultra true convection		
Convection Conversion		
Rapid Preheat		
Preheat countdown	Temperature	Temperature
Delay Bake		
Hold Warm		
Custom Broil		
Closed door broiling		
Sabbath Mode		
Control lock		
Illuminated display (two-color)		
Oven lights	Incandescent	Incandescent
Total adjustable racks	2	3
New EasyView™ extra-large oven window		
GENERAL INFORMATION		
Bake element watts at 240/208 volts	2800W/2427W	2800W/2427W
Broil element watts at 240/208 volts	3600W/3120W	3600W/3120W
Convection element watts at 240/208 volts		2500W/2167W
Circuit amperage	40 Amps	40 Amps
Total connected load at 240 volts	5.5 kW	5.5 kW
Total connected load at 208 volts	4.6 kW	4.6 kW
27" Oven cavity size (H x W x D)	18" x 22" x 19"	
30" Oven cavity size (H x W x D)	18" x 25" x 19"	18" x 25" x 19"
DIMENSIONS AND COLORS		
Cutout height (A)	41"–41 1/2"	41"–41 1/2"
Cutout width (B)	28 1/2" / 25 1/2"	28 1/2"
Cutout depth (C)	24"	24"
Overall height (D)	42 3/4"	42 3/4"
Overall width (E)	30" / 27"	30"
Overall depth (F)	26 3/4"	26 3/4"
Available colors	W B S	W B S H E

Bold type indicates a step-up feature

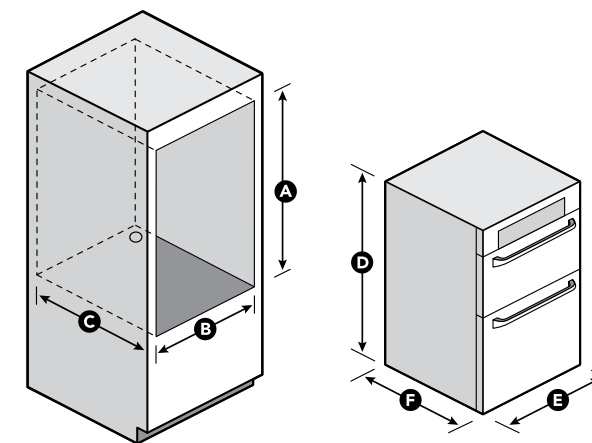

Electric Cooktops

SPECIFICATIONS AND DIMENSIONS

MODEL	WHIRLPOOL®		WHIRLPOOL GOLD®		
	RCS2012R	WCC31430A	W5CE3024X	G7CE3034X	G7CE3055X
New 2012 model	21" Coil	30" Coil	30" Ceramic glass	30" Ceramic glass	30" Ceramic glass
Recommended wall oven	WOS51EC0/7A WOD51EC0/7A WOC54EC0/7A	WOS51EC0/7A WOD51EC0/7A WOC54EC0/7A	WOS51EC0/7A WOD51EC0/7A WOC54EC0/7A	WOS92EC0/7A WOD93EC0/7A WOC95EC0A	WOS92EC0/7A WOD93EC0/7A WOC95EC0A
Volts/Circuit Amps or VAC required	240/20	240/40	240/30	240/40	240/40
PERFORMANCE FEATURES					
Element type	High-speed coil	High-speed coil	Radiant	Radiant	Radiant
Left rear element		8" 2,350-watt	7" 1,800-watt	10" 2,500-watt	6" 1,200-watt
Right rear element		6" 1,500-watt	6" 1,200-watt	6" 1,200-watt	6" 100-watt Warm Zone
Left front element	6" 1,250/900-watt	6" 1,500-watt	6" 1,200-watt	6" 1,200-watt	10" 2,500-watt
Right front element	8" 2,100/1,575-watt	8" 2,350-watt	9" 2,500-watt	12"/9" 3,000/1,900-watt AccuSimmer® dual	10"/6" 2,500/1,200-watt AccuSimmer® dual
Center rear element					6" 1,200-watt
Simmer function			♦	.	.
Chrome drip bowls	.	No Drip			
CONVENIENCE FEATURES					
Controls	Knobs	Knobs	Knobs	Stainless steel finish knobs	Stainless steel finish knobs
Dishwasher-safe control knobs		♦	.	.	.
Cooktop surface	Stainless steel	Porcelain SpillGuard™	Eco-friendly Schott Ceran®	Eco-friendly Schott Ceran® **	Eco-friendly Schott Ceran®
Infinite heat controls
Hot surface indicator lights
Power "On" light
Compatible above wall oven
DIMENSIONS AND COLORS					
Cutout width (A)	18 1/2"	28 3/8"	29 1/2"	29 1/2"	29 1/2"
Cutout depth (B)	15 1/2"	19 3/8"	20 1/2"	20 1/2"	20 1/2"
Height (C)	2 1/4"	3 1/4"	3 3/4"	3 3/4"	3 3/4"
Width (D)	21"	30"	30 3/8"	30 3/8"	30 3/8"
Depth (E)	16 1/2"	21"	21 1/4"	21 3/4"	21 3/4"
Available colors	S	W B R	W B S	P B C S	B S

Bold type indicates a step-up feature

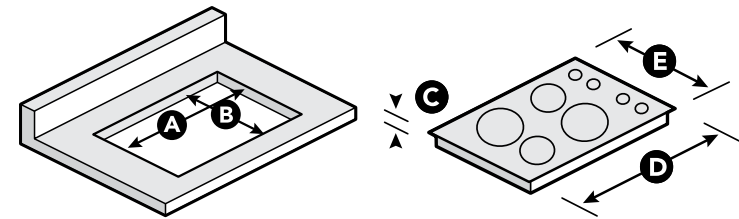

DIMENSIONS ARE SHOWN FOR PLANNING PURPOSES ONLY. For complete information, see Installation Instructions packed with product.

*Stainless Steel models only. **Eco-friendly designation does not apply to Pure White and Pure Biscuit Schott Ceran® cooktops

Electric Cooktops

SPECIFICATIONS AND DIMENSIONS

MODEL	WHIRLPOOL GOLD®		WHIRLPOOL®	WHIRLPOOL GOLD®			
	G9CE3065X	G9CE3074X	GCI3061X	W5CE3625A	G7CE3635X	G7CE3655X	G9CE3675X
New 2012 model	30" Ceramic glass	30" Ceramic glass	30" Induction	36" Ceramic glass	36" Ceramic glass	36" Ceramic glass	36" Ceramic glass
Recommended wall oven	WOS92EC0/7A WOD93EC0/7A WOC95EC0A	WOS92EC0/7A WOD93EC0/7A WOC95EC0A	WOS92EC0/7A WOD93EC0/7A WOC95EC0A	WOS92EC0/7A WOD93EC0/7A WOC95EC0A	WOS92EC0/7A WOD93EC0/7A WOC95EC0A	WOS92EC0/7A WOD93EC0/7A WOC95EC0A	WOS92EC0/7A WOD93EC0/7A WOC95EC0A
ADA compliant†	♦	♦
Volts/Circuit Amps or VAC required	240/30	240/40	240/40	240/40	240/40	240/40	240/40
PERFORMANCE FEATURES							
Element type	AccuSimmer® Plus radiant	AccuSimmer® Plus radiant	Induction	Radiant	Radiant	Radiant	AccuSimmer® Plus radiant
Left rear element	9" 2,200-watt	10"/6" 2,500/1,200-watt dual	9" 2,300/3,200-watt Boost	10" 2,500-watt	10"/6" 2,500/1,200-watt dual	8" 1,800-watt Bridge	10"/6" 2,500/1,200-watt dual
Right rear element	10"/6" 2,500/1,200-watt dual	12"/9"/6" 3,000/1,950/1,050-watt triple	8" 2,300-watt	10"/6" 2,500/1,200-watt dual	12"/9" 3,000/1,900-watt AccuSimmer® dual	12"/9"/6" 3,000/1,950/1,050-watt AccuSimmer® triple	12"/9"/6" 3,000/1,950/1,050-watt triple
Left front element	6" 1,200-watt	6" 1,200-watt	6" 1,400-watt	6" 1,200-watt	6" 1,200-watt	8" 1,800-watt Bridge	6" 1,200-watt
Right front element	6" 1,200-watt	6" 1,200-watt	6" 1,400-watt	6" 1,200-watt	6" 1,200-watt	6" 1,200-watt	6" 1,200-watt
Center rear element	6" 100-watt Warm Zone			6" 100-watt Warm Zone	6" 100-watt Warm Zone	6" 100-watt Warm Zone	6" 1,200-watt
Bridge element						♦	
Boost function			♦				
Simmer function
CONVENIENCE FEATURES							
Controls	Tap Touch	Tap Touch	Tap Touch	Knobs	Stainless steel finish knobs	Stainless steel finish knobs	Tap Touch
Dishwasher-safe control knobs			
Eco-friendly Schott Ceran® cooktop †
Infinite heat controls
Hot surface indicator lights
Power "On" light
Automatic pan detection			♦				
Timer			♦				
Control lock	♦	♦
Compatible above wall oven	♦	.	.
DIMENSIONS AND COLORS							
Cutout width (A)	29 1/2"	29 1/2"	29 1/2"	35 1/2"	35 1/2"	35 1/2"	35 1/2"
Cutout depth (B)	20 1/2"	20 1/2"	19 3/8"	20 1/2"	20 1/2"	20 1/2"	20 1/2"
Height (C)	3 1/4"	3 3/4"	2 3/4"	3 3/4"	3 3/4"	3 3/4"	3 3/4"
Width (D)	30 3/8"	30 3/8"	30 3/8"	36 1/8"	36 1/8"	36 1/8"	36 1/8"
Depth (E)	21 1/4"	21 3/4"	21 3/8"	21 3/4"	21 3/4"	21 3/4"	21 3/4"
Available colors	B S	B S	B	B	P B S	B S	B S

Bold type indicates a step-up feature

*Stainless Steel models only. **Eco-friendly designation does not apply to Pure White and Pure Biscuit Schott Ceran® cooktops. †Meets ADA push/pull force and reach guidelines.

Gas Cooktops

SPECIFICATIONS AND DIMENSIONS

MODEL	WHIRLPOOL®		WHIRLPOOL GOLD®			WHIRLPOOL®		WHIRLPOOL GOLD®		
	W3CG3014X	W5CG3024X	GLT3057R	G7CG3064X	GLS3064R	W5CG3625X	GLT3657R	G7CG3665X	GLS3665R	
	30" Porcelain or stainless steel	30" Porcelain or stainless steel	30" Tempered glass	30" Porcelain or stainless steel	30" Stainless steel	36" Porcelain or stainless steel	36" Tempered glass	36" Porcelain or stainless steel	36" Stainless steel	
Recommended wall oven	WOS51EC0/7A WOD51EC0/7A WOC54EC0/7A	WOS51EC0/7A WOD51EC0/7A WOC54EC0/7A	WOS92EC0/7A WOD93EC0/7A WOC95EC0A	WOS92EC0/7A WOD93EC0/7A WOC95EC0A	WOS92EC0/7A WOD93EC0/7A WOC95EC0A	WOS51EC0/7A WOD51EC0/7A WOC54EC0/7A	WOS92EC0/7A WOD93EC0/7A WOC95EC0A	WOS92EC0/7A WOD93EC0/7A WOC95EC0A	WOS92EC0/7A WOD93EC0/7A WOC95EC0A	
ADA compliant*	-	-	♦	♦	♦	♦	♦	♦	♦	
Volts/Amps required	120/15	120/15	120/15	120/15	120/15	120/15	120/15	120/15	120/15	
PERFORMANCE FEATURES										
Left rear burner	9,100 BTU	12,500 BTU Power™	9,100 BTU	9,200 BTU Power™	9,000 BTU	9,200 BTU	6,000 BTU AccuSimmer®	5,000 BTU AccuSimmer®	9,000 BTU	
Right rear burner	9,100 BTU	9,200 BTU Power™	6,000 BTU AccuSimmer®	15,000 BTU Power™	12,000 BTU Power™	9,200 BTU	6,000 BTU AccuSimmer®	12,500 BTU Power™	12,000 BTU Power™	
Left front burner	10,500 BTU	5,000 BTU AccuSimmer®	12,500 BTU Power™	17,000 BTU Power™	15,000 BTU Power™	9,200 BTU	12,500 BTU Power™	17,000 BTU Flex Power™	12,000 BTU Power™	
Right front burner	5,000 BTU AccuSimmer®	12,500 BTU Power™	12,500 BTU Power™	5,000 BTU AccuSimmer®	9,000 BTU	12,500 BTU Power™	12,500 BTU Power™	5,000 BTU AccuSimmer®	9,000 BTU	
Center rear burner						5,000 BTU AccuSimmer®	9,100 BTU	9,000 BTU Oval		
Center burner									15,000 BTU Power™	
CONVENIENCE FEATURES										
Control knobs	-	Dishwasher safe	Dishwasher safe	Dishwasher safe	-	Dishwasher safe	Dishwasher safe	Dishwasher safe	-	
Stainless steel finish control knobs**			♦					♦		
Recessed grate design					♦				♦	
Dishwasher-safe grates	Enamel steel	Full-width, cast-iron	Full-width, cast-iron	Full-width, cast-iron	Full-width, cast-iron	Full-width, cast-iron	Full-width, cast-iron	Full-width, cast-iron	Full-width, cast-iron	
Sealed burners	-	-	-	-	-	-	-	-	-	
Infinite heat controls	-	-	-	-	-	-	-	-	-	
Included LP conversion kit	-	-	-	-	-	-	-	-	-	
Compatible above wall oven	-	-	-	**	-	-	-	**	-	
DIMENSIONS AND COLORS										
Cutout width (A)	29"	29"	29"	29"	29 1/4"	35 1/4"	35 1/4"	35 1/4"	35 1/4"	
Cutout depth (B)	19"	19"	19"	19"	19 1/2"	19"	19"	19"	19 1/2"	
Height (C)	2 1/8"	3 7/16"	2 7/8"	3 1/2"	2 7/16"	3 1/8"	2 7/8"	3 1/2"	2 7/16"	
Width (D)	31 1/8"	29 1/2"	30 3/8"	31 1/8"	30"	36"	36 3/8"	37 1/16"	36"	
Depth (E)	21 1/4"	21 1/2"	21 1/4"	21"	20 1/4"	21"	21 1/4"	20 3/8"	20 1/4"	
Available colors	W B S	W B T S	B	B S	S	W B S	B	B S	S	

Bold type indicates a step-up feature

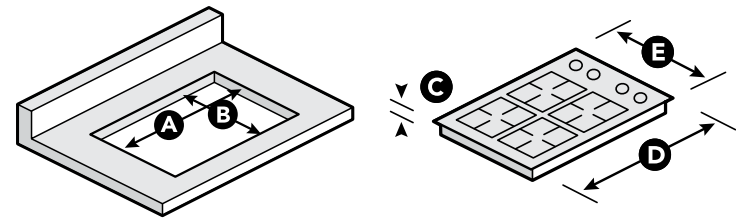

DIMENSIONS ARE SHOWN FOR PLANNING PURPOSES ONLY. For complete information, see Installation Instructions packed with product.

*Meets ADA push/pull force and reach range guidelines. **Stainless Steel models only.

Modular Cooktop

SPECIFICATIONS AND DIMENSIONS

MODEL	WHIRLPOOL®		
	SCM10D	SCM20D	SCM40D
	30" Modular Downdraft Gas Cooktop		
Recommended wall oven	WOS51EC0/7A WOD51EC0/7A WOC54EC0/7A		
FEATURES			
Downdraft vent	-		
10,000-BTU fixed burners	2		
Optional modules available	3†		
Infinite heat controls	-		
Dishwasher-safe control knobs	Lift off		
Dishwasher-safe, full-width, cast-iron, matte-finish grates	-		
Sealed burners	-		
Removable/washable vent filter	-		
Included LP conversion kit	-		
DIMENSIONS AND COLORS			
Cutout width (A)	28 1/4"		
Cutout depth (B)	20 3/8"		
Height (C)	4" - 16"		
Width (D)	29 1/4"		
Depth (E)	21 1/4"		
Available colors	B		
CONVENIENCE FEATURES			
Control knobs	-	Dishwasher safe	-
Stainless steel finish control knobs**			
Recessed grate design			
Dishwasher-safe grates	Enamel steel	Full-width, cast-iron	Full-width, cast-iron
Sealed burners	-	-	-
Infinite heat controls	-	-	-
Included LP conversion kit	-	-	-
Compatible above wall oven	-	-	-
DIMENSIONS AND COLORS			
Cutout width (A)	29"	29"	29"
Cutout depth (B)	19"	19"	19"
Height (C)	2 1/8"	3 7/16"	2 7/8"
Width (D)	31 1/8"	29 1/2"	30 3/8"
Depth (E)	21 1/4"	21 1/2"	21"
Available colors	W B S	W B T S	B

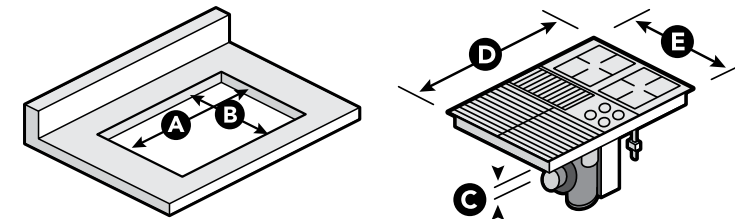

†Cooktop is shipped with one open bay and two fixed burners in the right bay. Select from the module options to complete your cooktop. Nonstick grill, surface burner and non-stick griddle modules available.

Microwave Hood Combinations

SPECIFICATIONS AND DIMENSIONS

MODEL	WHIRLPOOL®			WHIRLPOOL GOLD®		
	WMH31017A	WMH32517A	WMH53520A	WMH75520A	WMH76718A	GH7208XR
New 2012 model	-	-	-	-	-	-
Capacity (cu. ft.)	1.7	1.7	2.0	2.0	1.8	2.0
Stainless steel finish handle	-	-	-	-	-	-
COOKING SYSTEM						
Sensor cooking	-	♦	-	-	-	-
Power (watts)	1,000	1,000	1,000	1,100	1,100	1,200
Grill watts	-	-	-	-	-	1,500
AccuWave® power system	-	-	-	♦	-	♦
TimeSavor™ Plus true convection	-	-	-	-	♦	-
10 Variable power levels	-	-	-	-	-	-
SpeedCook technology with grilling	-	-	-	-	-	♦
Steam cooking	-	♦	-	-	-	-
Staged cooking	-	-	-	-	-	-
VENTILATION SYSTEM						
NEW! Auto Adapt fan	-	♦	-	-	-	-
Convertible ventilation system	2-speed, 220 CFM fan	3-speed, 300 CFM fan	4-speed, 400 CFM fan	4-speed, 300 CFM fan	4-speed, 300 CFM fan	4-speed, TruCapture® 300 CFM fan
Hidden vent	-	-	-	-	-	-
Filter change indicator	-	-	-	-	-	-
CYCLES						
Broil function	-	-	-	-	-	♦
Convection Bake and Roast	-	-	-	-	♦	-
AccuSimmer™ cycle	-	♦	-	-	-	-
Auto Cook, Defrost, Reheat	-	-	-	-	-	-
Kids Menu	-	-	-	♦	-	♦
Melt/Soften	-	-	-	-	-	-
Warm Hold	-	♦	-	-	-	-
CONVENIENCE FEATURES						
CleanRelease® non-stick interior	-	-	♦	-	-	-
Most Used button	-	-	-	-	-	♦
Touch screen controls	-	-	-	-	-	♦
Control lock	-	-	-	-	-	-
Add 30 seconds	-	-	-	-	-	-
Recessed glass turntable	-	Stoppable	Stoppable	Stoppable	Stoppable	Stoppable
Cooking rack	-	♦	-	-	Cooking and convection racks	Grill rack
Timer display color	Blue	Blue	Blue	Blue	Blue	Touch screen
EZ-Vue™ lighting	-	-	-	-	-	Halogen lighting
Night-light setting	-	-	-	-	-	-
ACCESSORIES						
Microwave Steamer	-	-	-	Optional	♦	-
Crisper pan with handle	-	-	-	-	-	-
Grease filter part number	W10208631A	W10208631A	W10208631A	W10208631	W10208631	W10120839A
Charcoal filter part number	8206230A	8206230A	8206230A	8206230A	8206230A	W10120840A
DIMENSIONS AND COLORS						
Minimum cutout width (A)	30"	30"	30"	30"	30"	30"
Minimum install height (B)	66"	66"	66"	66"	66"	66"
Height (C)	17 1/4"	17 1/4"	17 1/4"	17 1/4"	17 1/4"	15 1/4"
Width (D)	29 3/8"	29 3/8"	29 3/8"	29 3/8"	29 3/8"	29 3/8"
Depth (E)	16 1/2"	16 1/2"	16 1/2"	16"	16"	18 1/2"
Available colors	W B D S	W B T S	W B S H E	W B S	W B S	Q B S Y

Bold type indicates a step-up feature

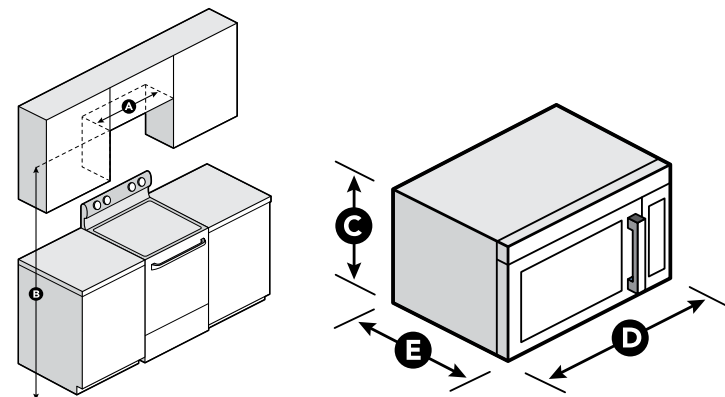

*Available on Stainless Steel, Monochromatic Stainless Steel, White Ice and Black Ice models only.

DIMENSIONS ARE SHOWN FOR PLANNING PURPOSES ONLY. For complete information, see Installation Instructions packed with product.

Countertop Microwaves

SPECIFICATIONS AND DIMENSIONS

MODEL	WHIRLPOOL®				
	WMC10007A	WMC10511A	WMC11511A	WMC30516A	WMC20005Y
New 2012 model	-	-	-	-	-
Capacity (cu. ft.)	0.7	1.1	1.1	1.6	0.5
COOKING SYSTEM					
Sensor cooking	-	♦	-	-	-
Power (watts)	700	1,000	1,000	1,200	750
10 Variable power levels	-	-	-	-	-
Staged cooking	-	♦	-	-	-
PROGRAMMED CYCLES AND SENSOR FUNCTIONS					
Soups/Sauces					
Dinner Plate	Programmed	Sensor	Sensor	Sensor	Programmed
Pizza Reheat	Programmed	Programmed	Programmed	Programmed	Programmed
Beverage	Programmed	Programmed	Programmed	Programmed	Programmed
Frozen Entree	Programmed	Sensor	Sensor	Sensor	Programmed
Popcorn	Programmed	Programmed	Programmed	Programmed	Programmed
Fresh Vegetables	Programmed	-	-	-	-
Baked Potato	Programmed	Programmed	Programmed	Programmed	-
CYCLES					
Manual Cook	-	-	-	-	♦
Auto Defrost	-	-	-	-	-
Manual Reheat	-	-	-	-	♦
CONVENIENCE FEATURES					
Electronic touch controls	-	-	-	-	Tap Touch
Time cook	-	-	-	-	-
Add-a-Minute option	-	-	-	-	-
Add 30 seconds option	-	♦	-	-	-
Control lock	-	-	-	-	-
Rounded-back design	-	-	-	-	♦
Turntable	-	Recessed glass	Recessed glass	Recessed glass	Glass
Microwave Built-in trim kit	-	-	-	Optional	-
Under counter mounting bracket	-	-	-	-	-
DIMENSIONS AND COLORS					
Height (A)	13 3/8"	12 1/8"	12 1/8"	13"	14 1/4"
Width (B)	17 3/8"	20 1/4"	20 1/4"	21 1/4"	15 3/8"
Depth (C)	10 3/8"	16 1/2"	16 1/2"	17 1/4"	13 3/4"
Available colors	W B	W B	S	W B S	W B D

Bold type indicates a step-up feature

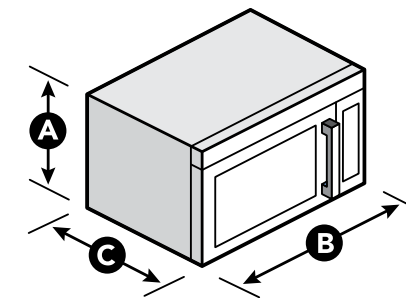

Under Cabinet Hoods

SPECIFICATIONS AND DIMENSIONS

MODEL	WHIRLPOOL GOLD*						
	UXT2030AY	UXT3030AY	UXT4030AY	UXT4230AY	UXT5230AY	UXT5530AA	GXU7130DX
Also available in 36"	30" Traditional	30" Traditional	30" Traditional	30" Traditional	30" Traditional	30" High Performance	30" Traditional
Vertical venting	UXT2036AY	UXT3036AY	UXT4036AY	UXT4236AY	UXT5236AY	UXT5536AA	
Horizontal venting	Exterior	Exterior	Interior	Exterior and Interior	Exterior and Interior	Exterior and Interior	Exterior
Type	Top venting only	Top and rear venting	Recirculating only	Convertible	Convertible	Convertible	Vented only
DUCT TYPE							
7" Round duct	Included			Included	W10355451		
3 1/4" x 10" Rectangular duct		Included		Included	Included	Included	Included
Dishwasher-safe grease filter	1	1		1	1	2 (30") or 3 (36")	2
FEATURES							
ENERGY STAR® qualified							
Maximum exhaust (CFM)*	190	190		225	350	400	300
Sones*	up to 4.5	up to 5.3		up to 7	up to 9	up to 8.2	up to 7.2 (.32 working speed)
Controls	2-speed, rocker switch	2-speed, rocker switch	2-speed, rocker switch	Variable speed, rotary	3-speed, push-button	3-speed, push-button	3-speed, push-button
Damper							
Fan	Axial	Axial	Axial	Axial	Axial	Centrifugal	Centrifugal
Lighting	75-watt On/Off incandescent	75-watt On/Off incandescent	75-watt On/Off incandescent	75-watt High/Low/Off incandescent	50-watt High/Low halogen (bulbs included)	50-watt High/Low halogen (bulbs included)	On/Off fluorescent
Recirculation kit/Charcoal filter			Included	Optional	Optional	Included	
Power cord included							
Damper/Vent connector included	7" Round	3 1/4" x 10" Rectangular		3 1/4" x 10" Rectangular	3 1/4" x 10" Rectangular	3 1/4" x 10" Rectangular	3 1/4" x 10" Rectangular
California Title 24 compliant			N/A				
ACCESSORIES							
Recirculation kit/Charcoal filter kit			W10355450	W10355450	W10369358 / W10386873	W10272068	
7" Round damper				W10355451	W10355451		
7" Damper plate				W10388168	W10388168		
Power cord	W10355452	W10355452	W10355452	W10355452	W10355452		
DIMENSIONS AND COLORS							
Cutout width (A)	30" / 36"	30" / 36"	30" / 36"	30" / 36"	30" / 36"	30" / 36"	30"
Minimum mounted height (B)	18"	18"	18"	18"	18"	24"	24" (Electric) 27" (Gas)
Height (C)	5"	5"	5"	5"	5"	9"	4 1/4"
Width (D)	29 3/8" / 35 3/8"	29 3/8" / 35 3/8"	29 3/8" / 35 3/8"	29 3/8" / 35 3/8"	29 3/8" / 35 3/8"	29 3/8" / 35 3/8"	29 3/8"
Depth (E)	18 1/2"	18 1/2"	18 1/2"	18 1/2"	18 1/2"	19 1/2"	20"
Cutout depth	11 1/8"	11 1/8"	11 1/8"	11 1/8"	11 1/8"	12"	
Available colors	W B	W B	W B T† S†	W B T† S	W B S	S	S

Bold type indicates a step-up feature

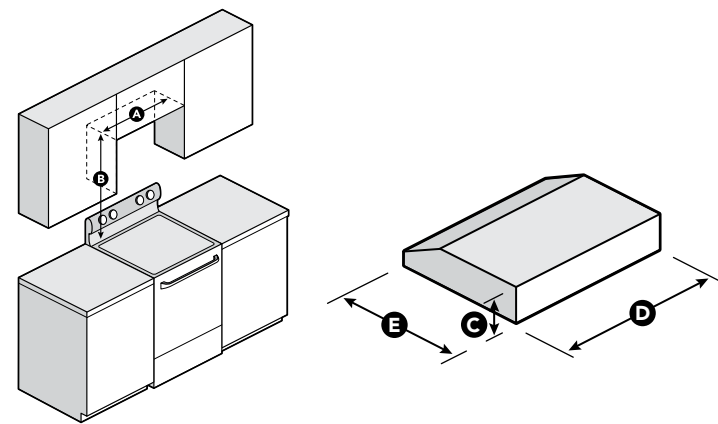

*View Use & Care Guide for more information. **UXT4030AY only. †UXT4230AY only.

DIMENSIONS ARE SHOWN FOR PLANNING PURPOSES ONLY. For complete information, see Installation Instructions packed with product.

Canopy Hoods

SPECIFICATIONS AND DIMENSIONS

MODEL	WHIRLPOOL GOLD*			
	GXW6530DX	GXI6536DX	GXW7230DA	GXW7330DX
New 2012 model				
Also available in 36"	30" Glass Wall-Mounted Canopy	36" Glass Island Canopy	30" Wall-Mounted Canopy	30" Wall-Mounted Canopy
Vertical venting	GXW6536DX			GXW7336DX
Type	Exterior and interior	Exterior and interior	Exterior and interior	Exterior and interior
	Convertible	Convertible	Convertible	Convertible
DUCT TYPE				
Included 6" round duct				
Dishwasher-safe grease filter	1	1	2	2
FEATURES				
ENERGY STAR® qualified				
Maximum exhaust (CFM)*	400	400	400	300
Sones*	up to 7.2	up to 7.2	up to 6.9 (2.4 working speed)	up to 6 (1.4 working speed)
3-speed push-button controls				
Damper				
Centrifugal fan				
Lighting (bulbs included)	On/Off incandescent	On/Off halogen	On/Off incandescent	On/Off fluorescent
Recirculation kit/Charcoal filter	Optional	Optional	Optional	Optional
Other accessories	Chimney extension kit	Chimney extension kit	Chimney extension kit	Chimney extension kit
DIMENSIONS AND COLORS				
A	13 1/8"	13 3/8"	8 1/8"	8 1/8" / 8 1/8"
B	10 3/8"	12 1/4"	7 1/4"	7 1/4" / 7 1/4"
Recirculating height (C)	27 1/4"–45 1/2"	29 3/4"–49 3/8"	28 1/4"–42 1/8"	28 3/8"–42 1/8"
Vented height (C)	27 3/8"–41 1/4"	29 3/4"–44 1/8"	28 3/8"–38"	28 3/8"–38"
Width (D)	30" / 36"	36"	30"	30" / 36"
Depth (E)	20"	25 3/8"	20"	20"
Minimum mounted height (above cooking surface)	24" (Electric) 27" (Gas)	24" (Electric) 27" (Gas)	24" (Electric) 27" (Gas)	24" (Electric) 27" (Gas)
Available colors	S	S	S	S

Bold type indicates a step-up feature

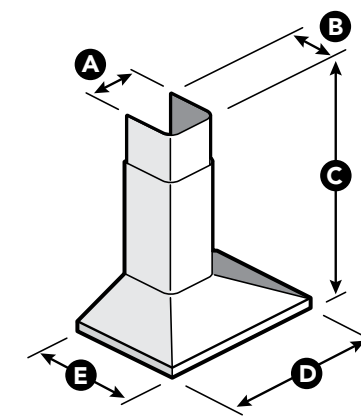

*View Use & Care Guide for more information.

Downdraft Vent

SPECIFICATIONS AND DIMENSIONS

MODEL	UXD8630DY
New 2012 model	-
Also available in 36"	30" Pop-Up Downdraft
Vertical venting	UXD8636DY
Horizontal venting	Exterior
Type	Vented only
DUCT TYPE	
6" Round duct	Included
3½" x 10" Rectangular duct	Included
Dishwasher-safe grease filter	2
FEATURES	
Maximum exhaust (CFM)*	600
Sones*	up to 7.9
Controls	4-speed slider
Damper	-
Fan	Dual centrifugal
Damper/Vent connector included	3½" x 10" Rectangular
DIMENSIONS AND COLORS	
A	10"
B	13½"
C	16½"
D	27" / 33"
E	2½"
F	28½"
G	30" / 36"
Available colors	S

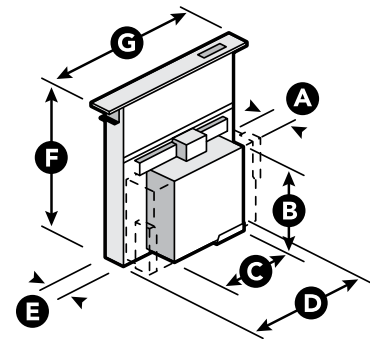

*View Use & Care Guide for more information.

DIMENSIONS ARE SHOWN FOR PLANNING PURPOSES ONLY. For complete information, see Installation Instructions packed with product.

Hood Liners

SPECIFICATIONS AND DIMENSIONS

MODEL	UXL5430BS	UXL6036YS	UXL6048YS
Vertical venting	30"	36" Under Cabinet	48" Under Cabinet
Type	Convertible	Vented	Vented
DUCT TYPE			
10" Round duct	-	♦	-
6" Round duct	-	-	-
FEATURES			
Auto-On Heat sensor	-	♦	-
Controls	3-speed, push button	3-speed, slider	3-speed, slider
Lighting	2, 50-watt On/Off halogen (bulbs included)	4, 50-watt High/Low halogen (bulbs included)	4, 50-watt High/Low halogen (bulbs included)
Dishwasher-safe grease filter	2	3	4
ACCESSORIES			
Blower motor systems	Included 400 CFM	Internal 600 CFM - UXB0600DYS Internal 1200 CFM - UXB1200DYS In-Line 600 CFM - UXI0600DYS In-Line 1200 CFM - UXI1200DYS	Internal 600 CFM - UXB0600DYS Internal 1200 CFM - UXB1200DYS In-Line 600 CFM - UXI0600DYS In-Line 1200 CFM - UXI1200DYS
Recirculation/Charcoal filter kit	W10490330	N/A	N/A
Face panel rear extension (30" x 18")	W10490327	N/A	N/A
Face panel (36" x 18")	W10490310	N/A	N/A
DIMENSIONS AND COLORS			
Height	13½"	11½"	11½"
Width	30"	35½"	47½"
Depth	11½"	22"	22"
Available colors	S	S	S

♦ Bold type indicates a step-up feature

Whirlpool brand is constantly improving and innovating our products, so the specifications in this catalog are subject to change.



VIDEO



DISHWASHERS

- 162 Built-in dishwashers
- 170 Compact dishwasher
- 171 Portable dishwasher
- 172 Food disposers
- 174 Trash compactors
- 176 Accessories
- 178 Glossary
- 180 Specifications



WDT910SAYH

DISHWASHERS



Industry's most energy-efficient dishwashers*

Our eco-friendly dishwashers not only meet CEE Tier 1** standards, they also use less water and energy without compromising performance.† Using our innovative resource-efficient wash system, these ENERGY STAR® qualified models will even save money on utility bills.



Takes the guesswork out of doing dishes

The Sensor cycle automatically selects the right wash and dry settings using two sensors that measure temperature, soil level and load size. It cleans tough soils 35% better†† using the right amount of time, energy and water.



Cleans without soaking or scrubbing

The enhanced PowerScour™ option uses 40 targeted spray jets in a designated wash area to scour away baked-on foods and deliver twice the coverage to clean your large pots and pans.



Flexible capacity

With features like the EZ-2-Lift™ adjustable upper rack and EZ Adjustable tines, you'll be able to take advantage of the large 15 place-setting capacity available on select Whirlpool® dishwashers.

NOTE: Not all features are available on all models.

*Based on average annual energy usage among leading brand dishwashers, MSRP \$399-\$749. **Based on the Consortium for Energy Efficiency qualifying product lists. Visit ceef.org for more information. †Compared to a conventional dishwasher manufactured before 2006. ††Compared to previous wash system.

Dishwashers

+ OPEN VIEW

WDF310PAA W | B | T | D | S

ENERGY STAR® qualified
Meets CEE Tier 1* standards
In-the-Rack silverware basket
Resource-efficient wash system
Quiet Partner™ I sound package
6" Console with electronic controls
White plastic tall tub

WDF510PAY W | B | T | D | S

New AnyWare™ Plus silverware basket
Quiet Partner™ II sound package
4" Console with electronic controls
ENERGY STAR® qualified
Meets CEE Tier 1* standards
Resource-efficient wash system
White plastic tall tub

+ OPEN VIEW

*Based on the Consortium for Energy Efficiency qualifying product lists. Visit cee1.org for more information.

Step-up features highlighted by yellow bar



Most Whirlpool® dishwashers are ENERGY STAR® qualified.

Dishwashers

WDF530PAY W | B | T | M

2½" Sleek console with electronic controls
Slate plastic tall tub
ENERGY STAR® qualified
Meets CEE Tier 1* standards
New AnyWare™ Plus silverware basket
Resource-efficient wash system
Quiet Partner™ II sound package

WDF550SAA W | B | S

Stainless steel tall tub
ADA height compliant**
ENERGY STAR® qualified
Meets CEE Tier 1* standards
In-the-Rack silverware basket
Resource-efficient wash system
Quiet Partner™ I sound package
5" Console with electronic controls

+ OPEN VIEW

*Based on the Consortium for Energy Efficiency qualifying product lists. Visit cee1.org for more information. **Meets ADA height requirements and must be installed in compliance with ADA Standards.

Feature descriptions can be found in the [glossary](#) on pages 178–179. Complete product specifications can be found on page 180.

Dishwashers

+ OPEN VIEW

WDT710PAY W | B | M | H | E

Whirlpool Gold® model

Sensor cycle

New AnyWare™ Plus silverware basket

Adjustable upper rack

Quiet Partner™ II sound package

Fully integrated electronic controls

White Ice and Black Ice color options

ENERGY STAR® qualified

Meets CEE Tier 1* standards

Resource-efficient wash system

Slate plastic tall tub

WDF730PAY W | B | T | M

Whirlpool Gold® model

New PowerScour™ option

EZ Adjustable tines

Sensor cycle

ENERGY STAR® qualified

Meets CEE Tier 1* standards

New AnyWare™ Plus silverware basket

Resource-efficient wash system

Adjustable upper rack

Quiet Partner™ II sound package

2½" Sleek console with electronic controls

Slate plastic tall tub

Dishwashers

+ OPEN VIEW

WDF750SAY W | B | M

Whirlpool Gold® model

Quiet Partner™ IV sound package

Stainless steel tall tub

Sensor cycle

ENERGY STAR® qualified

Meets CEE Tier 1* standards

New AnyWare™ Plus silverware basket

Resource-efficient wash system

2½" Sleek console with electronic controls

WDF775SAY W | B | M

Whirlpool Gold® model

New PowerScour™ option

Adjustable upper rack

Sensor cycle

ENERGY STAR® qualified

Meets CEE Tier 1* standards

New AnyWare™ Plus silverware basket

Resource-efficient wash system

Quiet Partner™ IV sound package

2½" Sleek console with electronic controls

Stainless steel tall tub



*Based on the Consortium for Energy Efficiency qualifying product lists. Visit cee1.org for more information.

Step-up features highlighted by yellow bar



Most Whirlpool® dishwashers are ENERGY STAR® qualified.

*Based on the Consortium for Energy Efficiency qualifying product lists. Visit cee1.org for more information.

Feature descriptions can be found in the [glossary](#) on pages 178–179. Complete product specifications can be found on page 181.

Dishwashers

+ OPEN VIEW

WDT90SAY W | B | M

Whirlpool Gold® model

Fully integrated electronic controls

Sensor cycle

ENERGY STAR® qualified

Meets CEE Tier 1* standards

New AnyWare™ Plus silverware basket

Resource-efficient wash system

Adjustable upper rack

Quiet Partner™ IV sound package

Stainless steel tall tub

Dishwashers

+ OPEN VIEW

WDT910SAY M | H | E

Whirlpool Gold® model

New PowerScour™ option

EZ Adjustable tines

EZ-2-Lift™ Adjustable upper rack

White Ice and Black Ice color options

Sensor cycle

ENERGY STAR® qualified

Meets CEE Tier 1* standards

New AnyWare™ Plus silverware basket

Resource-efficient wash system

Quiet Partner™ IV sound package

Fully integrated electronic controls

Stainless steel tall tub

*Based on the Consortium for Energy Efficiency qualifying product lists. Visit cee1.org for more information.

Step-up features highlighted by yellow bar



Most Whirlpool® dishwashers are ENERGY STAR® qualified.

*Based on the Consortium for Energy Efficiency qualifying product lists. Visit cee1.org for more information.

Feature descriptions can be found in the [glossary](#) on pages 178–179. Complete product specifications can be found on page 181.

Compact Dishwasher

+ OPEN VIEW

WDF518SAA W | B | M

ENERGY STAR® qualified
In-the-Rack silverware basket
Resource-efficient wash system
Quiet Partner™ I sound package
5" Console with electronic controls
Stainless steel tall tub

Portable Dishwasher

+ OPEN VIEW

DP1040TX Q | B

ENERGY STAR® qualified
AnyWare™ silverware basket
SheerClean™ direct-feed wash system
Electronic controls
White plastic tall tub



Most Whirlpool® dishwashers are ENERGY STAR® qualified.

Feature descriptions can be found in the [glossary](#) on pages 178–179. Complete product specifications can be found on pages 182–183.

Food Disposers



GC1000XE/PE*

- 1/3-HP motor
- Locked-in mounting
- Continuous-feed operation
- Overload protector
- Manual reset



GC2000XE/PE*

- 1/2-HP motor
- Locked-in mounting
- Continuous-feed operation
- Overload protector
- Manual reset

Food Disposers



GC5000XE

- 3/4-HP motor
- Stainless steel grinding wheel
- Sound insulation
- Locked-in mounting
- Continuous-feed operation
- Overload protector
- Manual reset

*Also available with plug and cord.

Step-up features highlighted by yellow bar

Feature descriptions can be found in the [glossary](#) on pages 178–179. Complete product specifications can be found on page 184.

Trash Compactors

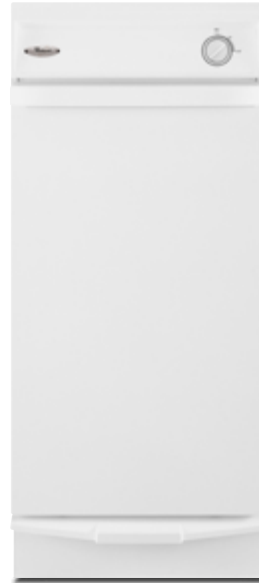

TU800SPP 1.4 cu. ft. Q | B
 1/3-HP motor
 Under counter
 Knob On/Off/Start
 Touch-Toe™ drawer opener
 Easy Rollers™ installation wheels



GX900QPP 1.4 cu. ft. Q | B | T | S
 Touch pad controls
Clean Touch™ console
 Tilt-Away trash basket
 1/3-HP motor
 Under counter
 Touch-Toe™ drawer opener
 Easy Rollers™ installation wheels

Step-up features highlighted by yellow bar

Trash Compactors



GC900QPP 1.4 cu. ft. Q | B
 Convertible freestanding-to-built-in
 1/3-HP motor
 Touch pad controls
Clean Touch™ console
 Touch-Toe™ drawer opener
 Easy Rollers™ installation wheels
 Tilt-Away trash basket



TU950QPX 1.4 cu. ft. S
 Fully integrated controls
 1/3-HP motor
 Under counter
 Touch-Toe™ drawer opener
 Easy Rollers™ installation wheels

Feature descriptions can be found in the [glossary](#) on pages 178–179. Complete product specifications can be found on page 185.

Accessories



Small Items Basket (3370993RB)

Fits all Whirlpool® dishwashers. It holds baby items, jar lids and other small utensils that would normally slip through the dishwasher rack.



Swivel Gooseneck Fitting (W10273460)

Space-saving 90° design makes this 3/4" x 3/8" elbow hose fitting perfect for easy dishwasher installation. A 3/8" brass compression fitting is included.



12' Drain Hose (3385556)

This flexible drain hose for tall tub dishwasher models offers a no-kink design made for hot water.



Small Items Bag (8519716)

Holds extra-small utensils, contact cases and other small items that would normally slip through the dishwasher rack.



3-Prong Dishwasher Power Supply Kit (W10278923RP)

This straight, 6', 90° UL-listed power cord kit fits dishwashers from most major brands and includes a power cord, metal strain relief bracket, wire nuts and instructions.



DishTrick® Capacity Extension Bundle (DISHEXTEND)

Clean large utensils and other odd-shaped items with this kit. Includes 6 light item clips, a side clip, a side utensil clip and a silverware basket.



DishTrick® Baby Bundle (DISHBABY)

Makes cleaning nipples, straws, silverware and bottles easy. Includes a small items basket, a baby bottle brush and 8 small item clips.



DishTrick® Wine Enthusiast Bundle (DISHSTEM)

Perfect for safely cleaning wine glasses in the dishwasher. Includes a StemGrip™ accessory (holds 2–4 stemware pieces) and a stemware brush.



affresh® Dishwasher Cleaner (W10282479)

Uses environmentally safer ingredients to help remove filming and spotting. Pouch contains 6 tablets.



White Dishwasher Rack Repair Kit (4396838RC)

This kit has everything you need to repair your dishwasher rack tines. It contains 150 tine tips, a 4-oz bottle of vinyl touch-up paint/adhesive with a brush and instruction sheet.

To acquire pricing information, order Whirlpool® dishwasher accessories and determine delivery time, visit whirlpool.com/accessories or call 1-800-462-3819.

Accessories

Hoses and Cords

Hoses include brass elbow, brass swivel and gooseneck fittings.

AVAILABLE ACCESSORY	
4' Red EPDM hose	W10278625RP
5' Red EPDM hose	W10278626RP
6' Red EPDM hose	W10278627RP
6' Braided hose	W10278635RP
6' Red EPDM hose	W10278627RC
6' Braided hose	W10278636RC
6' 3-prong dishwasher power supply kit	W10278923RP

Dishwasher Custom Panels and Optional Accessory Kits

MODEL	WDF510PAY
4" Console trim kit*	White - 4396200 Black - 4396199 Biscuit - 4396201
4" Wrap-around panel	Stainless Steel - 8171777
Side panel kit	White - 8171656 Black - 8171657 Biscuit - 8171658 Stainless Steel - 8171659

Mounting Kits

MODEL	WDF310PAA	WDF510PAY	WDF530PAY	WDT710PAY	WDF730PAY
Side mounting kit (plastic Tall tubs only)	8212560	8212560	8212560	8212560	8212560
Tall tub floor mounting kit	4378968	4378968	4378968	4378968	4378968

MODEL	WDF750SAY	WDT790SAY	WDT910SAY
Tall tub floor mounting kit	8171477**	8171477**	8171477**
Tall tub side mounting kit	Not required	Not required	Not required

*Trim Kit accommodates both a framed and frameless custom panel design. 6" custom panels for models WDF310PAA and DP1040XTX are not available at this time.

**Stainless steel Tall tub models only.

Glossary

1-Hour Wash cycle

Thoroughly cleans your dishes in nearly half the time.* This hour-long cycle lets you thoroughly clean your dirty dishes when you are in a rush.

ADA height compliant

Select dishwashers with this designation meet ADA height requirements and must be installed in compliance with ADA Standards.

Adjustable upper rack

Manually raise or lower the upper rack to better fit tall items.

AnyWare™ Plus silverware basket

Designed to clean better and fit in four places for maximum flexibility, the improved AnyWare™ Plus silverware basket rests on the bottom rack, the front of the lower rack or in the door for 100% usable rack space. It even makes room to hold up to 12 more pieces of silverware.

Auto soil sensor

Optimizes every cycle for reliable cleaning results. This sensor measures water clarity to determine how dirty dishes are, then adjusts the cycle accordingly. It measures the soils in the water and will add extra water and temperature to ensure clean dishes.

CEE Tier standards

Based on the Consortium for Energy Efficiency (CEE) qualifying product lists—with the Tier 1 standard being the most efficient. Visit cee1.org for more information.

Clean & Quiet Guarantee

If you are not completely satisfied that your new Whirlpool Gold® dishwasher is quieter and cleans better than your previous model, Whirlpool Corporation will take it back within 30 days of the date of purchase and refund the full price to you. Visit whirlpool.com for complete details and qualified models.

Clean Touch™ console

Select Whirlpool® trash compactors feature a smooth console with no dials or switches that cleans easily.

Control lock

Disables buttons on the control pad to help prevent accidental operation or children from starting or stopping the dishwasher.

Cup shelf

Allows you to stack two levels of coffee mugs or to secure delicate glassware when used as a stemware holder during the wash cycle.

Delay Wash option

Wash dishes according to your schedule. This option lets you delay washing for up to 8 hours until off-peak hours when utility rates may be lower.

Dynamic fills

The dishwasher monitors water level and ensures the correct amount of water is used for each load. All cycles include dynamic fills that change for every cycle and within the cycle.

Easy Rollers™ installation wheels

Easily position your Whirlpool® compactor where you need it with the Easy Rollers™ installation wheels.

Eco Dry option

The industry's first Eco Dry option is the most efficient drying option on our dishwashers** because it uses 70% less energy compared to using Heated Dry.

Eco Wash cycle

Our most efficient dishwasher cycle helps minimize energy and water usage while cleaning dishes.** It is great for cleaning lightly to moderately soiled dishes.

ENERGY STAR® qualified

Exceeds government standards to help conserve natural resources and save money on utility bills.

EZ-2-Lift™ adjustable upper rack

Easily adjust the upper rack 2" up or down to fit larger items in either rack. Improved to allow for 100% usable upper rack space, our easiest to adjust racks can be lifted or lowered to accommodate different size items and feature a narrow profile that doesn't interfere with loading.

EZ Adjustable tines

Innovative sliding lower-rack tines move left or right to fit your dishes. Now you have twice the space between tines to fit larger bowls for optimal cleaning.

Fold-down tines

Secure dishes during the wash cycle or can be folded down to create space for larger items.

Fully integrated electronic controls

Add a modern accent to your kitchen with a control panel that's hidden away and provides a sleek exterior while preventing unwanted cycle changes or accidental operation.

Heavy cycle

Adds more time to the cycle to clean heavily soiled items.

High Temperature Wash option

Choose this option when additional cleaning of items like baby bottles, glassware or dishes is required.

Light item clip

Secures lightweight items during the wash cycle and helps prevent items from falling out of the basket. They also stop cups and other small containers from flipping over and filling with water.

New PowerScour™ option

The new PowerScour™ option uses 40 targeted spray jets in a designated wash area to scour away baked-on foods without soaking or scrubbing. From casserole dishes to pots and pans, this option delivers twice the coverage to clean large items.

Normal cycle

Use for loads with normal amounts of food soil. This cycle is great for everyday loads.

NSF Certified Sani Rinse option

Sanitizes dishes by eliminating 99.999% of food soil bacteria, as certified by NSF International.

Nylon racks

Durable nylon coating helps resist rust and prevent scratching.

Overnight cycle

This industry-exclusive cycle quietly soaks your dishes with an extended prewash and then runs a tough soil wash to clean dirty dishes.

Quiet Partner™ sound packages

Whirlpool brand dishwashers offer many levels of sound-reducing insulation. The Quiet Partner™ IV sound package is the highest available.

Resource-efficient wash system

Efficiently cleans a full load of dishes using nearly half the water and energy.† This system provides excellent cleaning first in the upper rack, then the lower, to reduce the amount of water used.

Sensor cycle

Automatically selects the right wash and dry settings for your load by using two separate sensors to measure temperature, soil level and load size once during the prewash and once during the wash cycle. It cleans tough soils 35% better†† using just the right amount of time, energy and water.

Glossary

SheerClean™ wash system

Channels water up and out of the back and top of the dishwasher to powerfully clean from multiple angles. The filter keeps wash water clean and delivers sparkling-clean dishes.

Slate interior

Reduces the appearance of visible tub stains, wash after wash. Sophisticated slate styling gives the dishwasher an attractive, premium look.

Soak & Scour option

Gently soaks, powerfully cleans and then soaks again to remove tough soils from dishes so you don't have to.

Stainless steel interior

Adds a sleek, smooth texture to the interior of the dishwasher. Stainless steel provides higher heat retention to further improve drying performance, while also offering a high-end look.

Tall tub design

Allows you to load tall and odd-shaped items in both racks. An additional 3" of interior space compared to standard tub models makes room for extra-large items in the lower rack and plates or sports bottles in the upper rack.

Top Rack Wash option

Save time and energy with the Top Rack Wash option. It washes the top rack of dishes, so you don't have to wait for a full load to wash a few items.

Touch-Toe™ drawer opener

Easily open Whirlpool® trash compactors without your hands using the Touch-Toe™ drawer opener. A light tap of the toe is all that's needed to release the drawer.

*Compared to Normal cycle with lightly soiled loads. **Available on Whirlpool® models MSRP \$449 and above.

†Compared to dishwashers manufactured before 2006. ††Compared to previous wash system.

Dishwashers

SPECIFICATIONS AND DIMENSIONS

WHIRLPOOL®				
MODEL	WDF310PAA	WDF510PAY	WDF530PAY	WDF550SAA
New 2012 model	-	-	-	-
Replaces model	DU1010XTX	DU1055XTV	DU1300XTV	GU3100XTV
Place setting capacity	12	14	15	12
ENERGY STAR® qualified	-	-	-	-
Meets CEE Tier standards*	Tier 1	Tier 1	Tier 1	Tier 1
Tall tub design	-	-	-	-
Tub material	Plastic – White	Plastic – White	Plastic – Slate	Stainless steel
Sound package	Quiet Partner™ I (59 dBA)	Quiet Partner™ II (55 dBA)	Quiet Partner™ II (55 dBA)	Quiet Partner™ I (54 dBA)
ADA height compliant**	-	-	-	♦
WASH SYSTEM				
Resource-efficient wash system	-	-	-	-
Auto soil sensor	-	-	-	-
Dynamic fills	-	-	♦	-
Console height	6"	4"	2½"	5"
Electronic controls	-	-	-	-
5-level direct-feed	-	-	♦	-
4-level direct-feed	-	-	-	-
CYCLES				
Total number of cycles	3	5	5	5
Eco Wash	-	♦	-	-
Overnight	-	♦	-	-
1-Hour Wash	-	-	-	-
Pots & Pans	-	-	-	♦
Heavy	-	-	-	-
Normal	-	-	-	-
Light	-	-	-	♦
Rinse Only	-	-	-	♦
OPTIONS				
Total number of options	4	4	6	4
Eco Dry	-	-	♦	-
Heated Dry	-	-	-	-
NSF Certified Sani Rinse	-	♦	-	-
High Temperature Wash	-	-	-	-
Delay Wash	4 Hour	4 Hour	2-4-8 Hour	2-4-6 Hour
Control lock	-	-	♦	-
RACK FLEXIBILITY				
Rack coating	Vinyl	Vinyl	Nylon	Nylon
Light item clips	-	-	2	-
Cup shelves	-	-	♦	-
Silverware basket	In-the-Rack	New AnyWare™ Plus	New AnyWare™ Plus	In-the-Rack
DIMENSIONS AND COLORS				
Height (A)	33½"-34½"	33½"-34½"	33½"-34½"	32½"-34½"
Width (B)	23½"	23⅞"	23⅞"	24"
Depth (C)	24½"	24⅞"	24½"	24"
Minimum cutout height (D)	34"	34"	34"	34"
Cutout width (E)	24"	24"	24"	24"
Cutout depth (F)	24"	24"	24"	24"
Available colors	W B T D S	W B T D S	W B T M	W B S

Bold type indicates a step-up feature

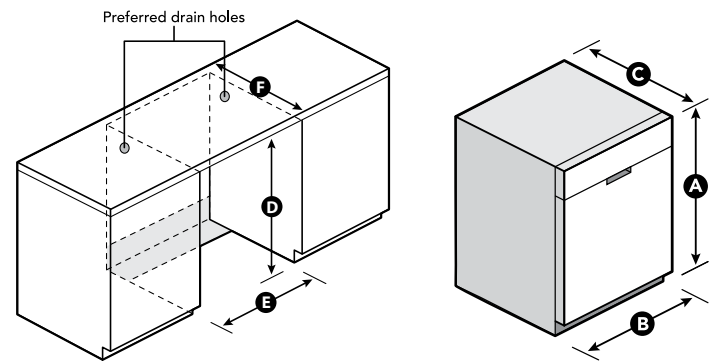

DIMENSIONS ARE SHOWN FOR PLANNING PURPOSES ONLY. For complete information, see Installation instructions packed with product.

*Based on the Consortium for Energy Efficiency qualifying product lists. Visit cee1.org for more information.
**Meets ADA height requirements and must be installed in compliance with ADA Standards.

Dishwashers

SPECIFICATIONS AND DIMENSIONS

WHIRLPOOL GOLD®						
MODEL	WDT710PAY	WDF730PAY	WDF750SAY	WDF775SAY	WDT790SAY	WDT910SAY
New 2012 model	-	-	-	-	-	-
Replaces model	GU2275XTV	GU2300XTV	-	-	GU3200XTX	GU3600XTV
Place setting capacity	15	15	15	15	15	15
ENERGY STAR® qualified	-	-	-	-	-	-
Meets CEE Tier standards*	Tier 1	Tier 1	Tier 1	Tier 1	Tier 1	Tier 1
Tall tub design	-	-	-	-	-	-
Tub material	Plastic – Slate	Plastic – Slate	Stainless steel	Stainless steel	Stainless steel	Stainless steel
Sound package	Quiet Partner™ II (55 dBA)	Quiet Partner™ II (55 dBA)	Quiet Partner™ IV (51 dBA)	Quiet Partner™ IV (51 dBA)	Quiet Partner™ IV (51 dBA)	Quiet Partner™ IV (51 dBA)
30-Day Clean & Quiet guarantee†	♦	-	-	-	-	-
DISHWASHER SYSTEM						
5-level direct-feed Resource-efficient wash system	-	-	-	-	-	-
Auto soil sensor	♦	-	-	-	-	-
Dynamic fills	♦	-	-	-	-	-
Console height	Fully integrated	2½"	2½"	2½"	Fully integrated	Fully integrated
Electronic controls	-	-	-	-	-	-
CYCLES						
Total number of cycles	6	6	5	6	6	6
Sensor	♦	-	-	-	-	-
Eco Wash	-	-	-	-	-	-
Overnight	-	-	-	♦	-	-
1-Hour Wash	-	-	-	-	-	-
Heavy	-	-	-	-	-	-
Normal	-	-	-	-	-	-
OPTIONS						
Total number of options	7	7	6	7	7	7
Eco Dry	♦	-	-	-	-	-
Heated Dry	-	-	-	-	-	-
Top Rack Wash	♦	-	-	-	♦	-
New PowerScour™	-	♦	-	♦	-	♦
NSF Certified Sani Rinse	♦	-	-	-	-	-
High Temperature Wash	-	-	-	-	-	-
Delay Wash	4 Hour	2-4-8 Hour	2-4-8 Hour	2-4-8 Hour	4 Hour	4 Hour
Control lock	-	-	-	-	-	-
RACK FLEXIBILITY						
Nylon rack coating	-	-	-	-	-	-
Adjustable upper rack	♦	-	-	♦	-	EZ-2-Lift™
Light item clips	2	2	2	-	2	2
Cup shelves	-	-	-	-	-	-
EZ Adjustable tines	-	♦	-	-	-	♦
2 Upper rack fold-down tines	♦	-	-	-	-	♦
Lower rack fold-down tines	-	♦	-	-	-	♦
New AnyWare™ Plus silverware basket	♦	-	-	-	-	-
Premium rail system	♦	-	-	♦	-	-
DIMENSIONS AND COLORS						
Height (A)	33½"-34½"	33½"-34½"	33½"-34½"	33½"-34½"	33½"-34½"	33½"-34½"
Width (B)	23½"	23⅞"	23⅞"	23⅞"	23⅞"	23⅞"
Depth (C)	24½"	24½"	24½"	24½"	24½"	24½"
Minimum cutout height (D)	34"	34"	34"	34"	34"	34"
Cutout width (E)	24"	24"	24"	24"	24"	24"
Cutout depth (F)	24"	24"	24"	24"	24"	24"
Available colors	W B M H E	W B T M	W B M	W B M	W B M	M H E

Bold type indicates a step-up feature

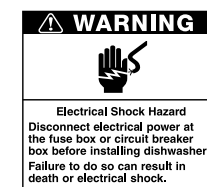

Electrical requirements

Rated load is 11.0 amps, 120 volts, 60 Hz AC.
15-amp (20-amp max) circuit required.
When local codes permit, any Whirlpool® dishwasher plus a disposer up to 7.2 amps can be installed on a single 20-amp circuit. Do not use an extension cord.
Water Pressure — 15 to 120 psi.
Recommended incoming water temperature — 120°F minimum.
Listed by Underwriters Laboratories.

*Based on the Consortium for Energy Efficiency qualifying product lists. Visit cee1.org for more information. †Visit whirlpool.com for complete details and qualified models.

Compact Dishwasher

SPECIFICATIONS AND DIMENSIONS

MODEL	WHIRLPOOL® WDF518SAA
New 2012 model	.
Place setting capacity	8
ENERGY STAR® qualified	.
Tall tub design	.
Tub material	Stainless steel
Sound package	Quiet Partner™ 1 (57 dBA)
WASH SYSTEM	
4-level direct-feed Resource-efficient wash system	.
Console height	5"
Electronic controls	.
CYCLES	
Total number of cycles	5
Pots & Pans	.
Heavy	.
Normal	.
Quick Wash	.
Rinse Only	.
OPTIONS	
Total number of options	2
Heated Dry	.
Delay Wash	2-4-8 Hour
RACK FLEXIBILITY	
Nylon rack coating	.
Cup shelves	.
Silverware basket	In-the-Rack
DIMENSIONS AND COLORS	
Height (A)	32½"-35"
Width (B)	17½"-18"
Depth (C)	22"
Minimum cutout height (D)	34"
Cutout width (E)	17¼"-18"
Cutout depth (F)	24"
Available colors	W B M

Portable Dishwasher

SPECIFICATIONS AND DIMENSIONS

MODEL	WHIRLPOOL® DP1040XTX
ENERGY STAR® qualified	.
Tall tub design	.
White plastic tub	.
WASH SYSTEM	
4-level SheerClean™ direct-feed wash system	.
Electronic controls	.
CYCLES	
Total number of cycles	5
Eco	.
1-Hour Wash	.
Pots & Pans	.
Normal	.
Rinse Only	.
OPTIONS	
Total number of options	4
Heated Dry	.
High Temperature Wash	.
Delay Wash	4 Hour
Control lock	.
RACK FLEXIBILITY	
Vinyl rack coating	.
AnyWare™ silverware basket	.
DIMENSIONS AND COLORS	
Height (A)	35½"-37"
Width (B)	24½"
Depth (C)	24½"
Available colors	Q B

Dishwasher Custom Panels

SPECIFICATIONS AND DIMENSIONS

DIMENSIONS	4" FRAMELESS	4" FRAMED
Height (A)	25½/32"	26"
Width (B)	23¼"	23½"
Thickness (C)	¾"	¾"

Installation Notes

1. Custom panel for door cannot exceed 8-lb weight
2. Upper and lower panels are not the same width
3. Match woodgrain direction with that of adjacent cabinets
4. Sand panel edges to provide a smooth finish
5. Use moisture-resistant sealer on sides and edges of panels to protect from humidity (Dishwasher is subject to humidity)



Electrical requirements

Rated load is 11.0 amps, 120 volts, 60 Hz AC.
15-amp (20-amp max) circuit required.

When local codes permit, any Whirlpool® dishwasher plus a disposer up to 7.2 amps can be installed on a single 20-amp circuit. Do not use an extension cord.

Water Pressure — 15 to 120 psi.

Recommended incoming water temperature — 120°F minimum.

Listed by Underwriters Laboratories.

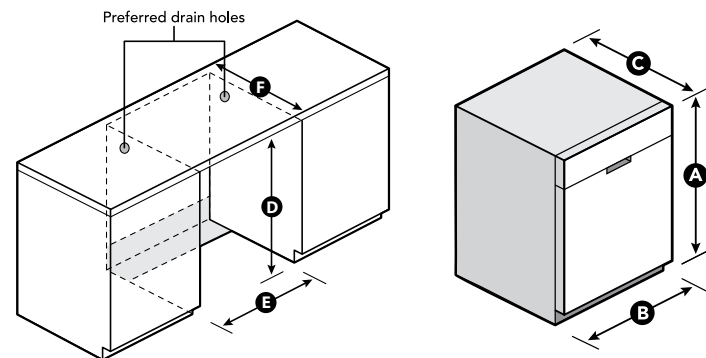

DIMENSIONS ARE SHOWN FOR PLANNING PURPOSES ONLY.
For complete information, see Installation instructions packed with product.

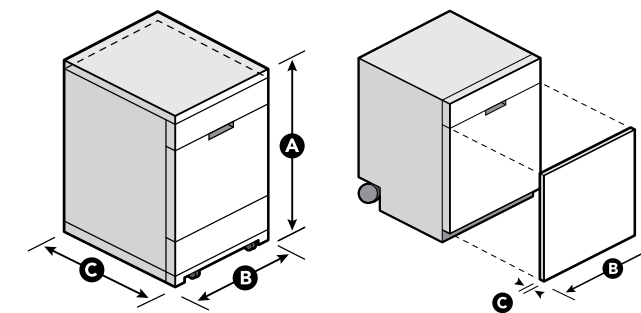

Food Disposers

SPECIFICATIONS AND DIMENSIONS

MODEL	WHIRLPOOL®		
	GC1000XE/PE	GC2000XE/PE	GC5000XE
Motor	½-HP	½-HP	¾-HP
Locked-in mounting	-	-	-
Continuous-feed operation	-	-	-
Stainless steel grinding wheel	-	-	♦
Overload protector	-	-	-
Manual reset	-	-	-
Sound insulation	-	-	♦
DIMENSIONS			
A	11½"	11½"	12¾"
B	5 ⅝"	5 ⅝"	6 ⅝"
C	4"	4"	4"
D	6 ⅝"	6 ⅝"	7 ¼"
E	5"	5"	5 ¼"

Bold type indicates a step-up feature

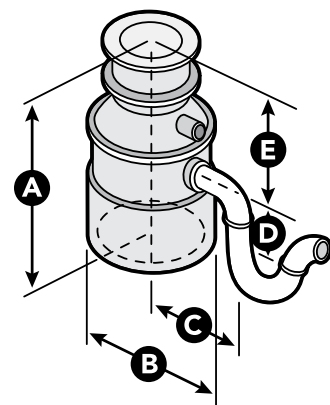

*Also available with plug and cord.

DIMENSIONS ARE SHOWN FOR PLANNING PURPOSES ONLY. For complete information, see installation instructions packed with product.

Trash Compactors

SPECIFICATIONS AND DIMENSIONS

MODEL	WHIRLPOOL®			
	TU800SFP	GX900GPP	GC900GPP	TU950GFX
Capacity (cu. ft.)	1.4	1.4	1.4	1.4
Convertible freestanding-to-built-in	-	-	♦	-
Under counter	-	-	-	-
Touch pad controls	-	♦	-	-
Fully integrated controls	-	-	-	♦
Knob On/Off/Start	-	-	-	-
Wrap around drawer panel	-	-	-	-
Automatic anti-jam	-	-	-	-
Clean Touch™ console	-	♦	-	-
Touch-Toe™ drawer opener	-	-	-	-
"Hidden" removable key control knob	-	♦	-	-
Easy Rollers™ installation wheels	-	-	-	-
½-HP motor	-	-	-	-
4-to-1 Compaction ratio	-	-	-	-
Front levelers/rear rollers	-	-	-	-
Bag retainer buttons	-	-	-	-
Side release bin	-	-	-	-
Tilt-Away trash basket	-	♦	-	-
Tilt switch	-	-	-	-
DIMENSIONS AND COLORS				
Height (A)	34 ¼"	34 ¼"	34 ¼"	33 ¼"
Width (B)	15"	15"	15"	15"
Depth (C)	24"	24"	24"	24"
Minimum cutout height (D)	34 ¼"	34 ¼"	34 ¼"	34 ¼"
Cutout width (E)	15 ⅝"	15 ⅝"	15 ⅝"	15 ⅝"
Cutout depth (F)	24 ¾"	24 ¾"	24 ¾"	24 ¾"
Height to outlet (G)	18"	18"	18"	18"
Available colors	Q B	Q B T S	Q B	S

Bold type indicates a step-up feature

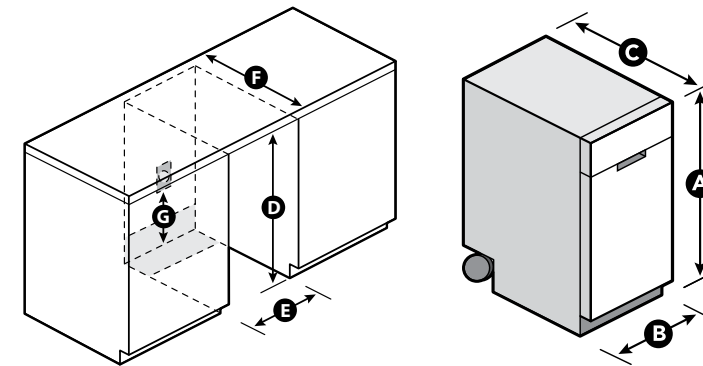

Whirlpool brand is constantly improving and innovating our products, so the specifications in this catalog are subject to change.



VIDEO



LAUNDRY

- 188 [High efficiency \(HE\) front load laundry](#)
- 198 [High efficiency \(HE\) top load laundry](#)
- 208 [Traditional top load laundry](#)
- 214 [Laundry 1-2-3™ custom laundry options](#)
- 216 [Specialty laundry pairs](#)
- 218 [Accessories](#)
- 220 [Glossary](#)
- 222 [Specifications](#)



WFW96HEAU & WE/GD96HEAU

HIGH EFFICIENCY FRONT LOAD LAUNDRY

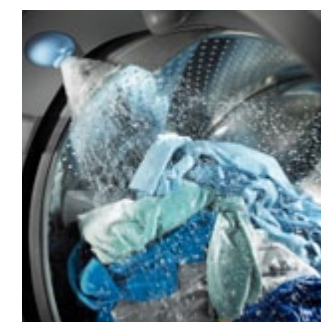

Sprays detergent evenly

Active Spray technology cleans better by spraying the load with detergent in a cone-shaped pattern to completely and evenly cover fabrics. It delivers better cleaning performance that virtually eliminates the need to pretreat.

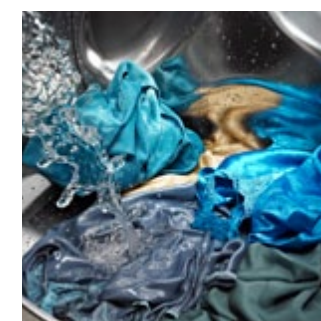

Cleans better with less detergent

Precision Dispense Ultra senses and adapts to each load, adding bleach and fabric softener at just the right time during the cycle. The removable detergent reservoir can hold enough detergent for up to 12 loads of laundry in a single filling.*

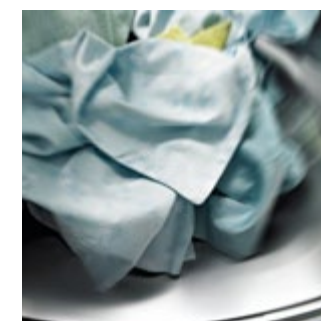

Keeps clean clothes fresh

When the FanFresh® option with Dynamic Venting Technology® is activated, select models automatically tumble clothes for up to 12 hours until you're ready to toss them in the dryer. You can even wash and dry a small load right in the washer.**

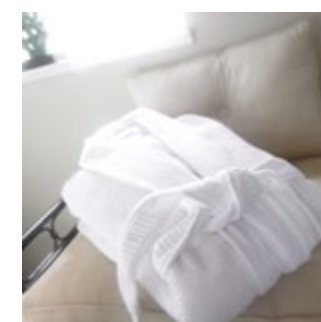

Automatically stops when items are perfectly dry

Advanced Moisture Sensing uses built-in sensors to read incoming and outgoing air temperatures, while monitoring moisture levels inside the dryer. This helps the drying cycle end when everything is perfectly dry, saving time and energy and preventing overdrying.

NOTE: Not all features are available on all models.

*Based on 2X concentration of HE detergent. **Based on a 2-lb load of lightweight fabrics.

Duet® HE Front Load Washers



WFW9151Y 3.5 cu. ft. W

Recommended dryer: WE/GD9151Y
Precision Dispense
TumbleFresh™ option
ENERGY STAR® qualified
Meets CEE Tier 3* standards
Quiet Spin technology
EcoBoost™ option



WFW9351Y 3.5 cu. ft. W

Recommended dryer: WE/GD9371Y
NSF Certified Sanitize options with heater
Eco Monitor
Precision Dispense
TumbleFresh™ option
ENERGY STAR® qualified
Meets CEE Tier 3* standards
Quiet Spin technology
EcoBoost™ option

Duet® HE Front Load Dryers



WE/GD9151Y 6.7 cu. ft. W

Recommended washer: WFW9151Y
AccelerCare® drying system
90-minute Wrinkle Shield™ option
Eco Normal cycle



WE/GD9371Y 6.7 cu. ft. W

Recommended washer: WFW9351Y
Steam-enhanced cycles
Quiet Dry system
AccelerCare® drying system
90-minute Wrinkle Shield™ option
Eco Normal cycle

*Based on the Consortium for Energy Efficiency qualifying product lists. Visit cee1.org for more information.

Step-up features highlighted by yellow bar



Most Whirlpool® washers are ENERGY STAR® qualified.

Feature descriptions can be found in the [glossary](#) on pages 220–221. Complete product specifications can be found on pages 222–223.

Duet® HE Front Load Washers



WFW9550W 3.8 cu. ft. W | L

Recommended dryer: WE/GD9550W

- Steam-enhanced cycles
- Direct Inject wash system
- Precision Dispense
- TumbleFresh™ option
- ENERGY STAR® qualified
- Meets CEE Tier 3* standards
- NSF Certified Sanitize options with heater

Duet® HE Front Load Dryers



WE/GD9550W 7.2 cu. ft. W | L

Recommended washer: WFW9550W

- 140-minute Wrinkle Shield™ Plus option
- Quiet Dry Plus system
- AccelerCare® drying system
- Steam-enhanced cycles
- Eco Normal cycle



WE/GD9470W 7.2 cu. ft. W

- Chrome accents
- AccelerCare® drying system
- Steam-enhanced cycles
- 140-minute Wrinkle Shield™ Plus option
- Quiet Dry Plus system
- Eco Normal cycle

*Based on the Consortium for Energy Efficiency qualifying product lists. Visit cee1.org for more information.

Step-up features highlighted by yellow bar



Most Whirlpool® washers are ENERGY STAR® qualified.

Feature descriptions can be found in the [glossary](#) on pages 220–221. Complete product specifications can be found on pages 222–223.

Duet® HE Front Load Washers



WFW88HEA 4.3 cu. ft. W | C

Recommended dryer: WE/GD88HEA

- EcoBoost™ option**
- NSF Certified Sanitize cycle** with Steam and heater
- Tap Touch controls**
- Eco Monitor**
- Quiet Spin 360 technology
- Precision Dispense
- ENERGY STAR® qualified
- Meets CEE Tier 3* standards
- Steam-enhanced cycles
- Adaptive Clean wash system



WFW94HEA 4.3 cu. ft. W | C

Recommended dryer: WE/GD94HEA

- 12-hour FanFresh® option with Dynamic Venting Technology®**
- EcoBoost™ option**
- NSF Certified Sanitize cycle** with Steam and heater
- Tap Touch controls**
- Eco Monitor**
- Quiet Spin 360 technology
- Precision Dispense
- ENERGY STAR® qualified
- Meets CEE Tier 3* standards
- Steam-enhanced cycles
- Adaptive Clean wash system

Duet® HE Front Load Dryers



WE/GD88HEA 7.4 cu. ft. W | C

Recommended washer: WFW88HEA

- Tap Touch controls**
- Advanced Moisture Sensing**
- EcoBoost™ option**
- 140-minute **Wrinkle Shield™ Plus option** with Steam
- Quiet Dry Ultra system**
- Eco Monitor**
- Steam-enhanced cycles



WE/GD94HEA 7.4 cu. ft. W | C

Recommended washer: WFW94HEA

- Static Reduce option**
- Tap Touch controls**
- Advanced Moisture Sensing**
- EcoBoost™ option**
- 140-minute **Wrinkle Shield™ Plus option** with Steam
- Quiet Dry Ultra system**
- Eco Monitor**
- Steam-enhanced cycles

*Based on the Consortium for Energy Efficiency qualifying product lists. Visit cee1.org for more information.

Step-up features highlighted by yellow bar



Most Whirlpool® washers are ENERGY STAR® qualified.

Feature descriptions can be found in the [glossary](#) on pages 220–221. Complete product specifications can be found on pages 224–225.

Duet® HE Front Load Washers



WFW96HEA 4.3 cu. ft. W | C | U

Recommended dryer: WE/GD96HEA

Precision Dispense Ultra

Active Spray technology

12-hour FanFresh® option with Dynamic Venting Technology®

ENERGY STAR® qualified

Meets CEE Tier 3* standards

EcoBoost™ option

Steam-enhanced cycles

NSF Certified Sanitize cycle with Steam and heater

Tap Touch controls

Adaptive Clean wash system

Quiet Spin 360 technology

RATED A
RECOMMENDED BUY*



WFW97HEX 4.3 cu. ft. W | L

Recommended dryer: WE/GD97HEX

Laundry Apps with Stain Assist

Full-color widescreen LCD display

Precision Dispense Ultra

16-hour FanFresh® option with Dynamic Venting Technology®

ENERGY STAR® qualified

Meets CEE Tier 3** standards

EcoBoost™ option

Steam-enhanced cycles

NSF Certified Sanitize options with Steam and heater

Direct Inject wash system

Quiet Spin 360 technology

Duet® HE Front Load Dryers



WE/GD96HEA 7.4 cu. ft. W | C | U

Recommended washer: WFW96HEA

SilentSteel™ dryer drum

Tap Touch controls

Advanced Moisture Sensing

EcoBoost™ option

Steam-enhanced cycles

140-minute Wrinkle Shield™ Plus option with Steam

Static Reduce option

Quiet Dry Ultra system

Eco Monitor

WE/GD97HEX 7.4 cu. ft. W | L

Recommended washer: WFW97HEX

Laundry Apps

Full-color widescreen LCD display

Advanced Moisture Sensing

SilentSteel™ dryer drum

EcoBoost™ option

Steam-enhanced cycles

140-minute Wrinkle Shield™ Plus option with Steam

Static Reduce option

Quiet Dry Ultra system

Eco Monitor

*According to a leading consumer magazine. **Based on the Consortium for Energy Efficiency qualifying product lists. Visit cee1.org for more information.

Step-up features
highlighted by
yellow bar



Most Whirlpool® washers
are ENERGY STAR® qualified.

Feature descriptions can be found in the [glossary](#) on pages 220–221. Complete product specifications can be found on pages 224–225.



WTW8800YC & WE/GD8800YC

HIGH EFFICIENCY TOP LOAD LAUNDRY



Best care for your clothes*

The Clean Care cycle beautifully blends cold water with adaptive wash actions to help remove stains and protect your clothes from color fading and bleeding. Advanced Moisture Sensing in the dryer automatically keeps heat consistent to help prevent overdrying and shrinking.



Industry's most resource-efficient top load pair**

Save time, money and energy with an ENERGY STAR® qualified washer and high-efficiency dryer. These laundry pairs more than pay for themselves, saving you over \$3,100 in lifetime water and energy costs.†

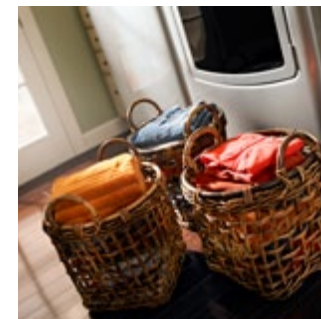

Industry's largest capacity pair††

Wash up to 3 baskets of laundry in a single load with this 4.6 cu. ft. washer. Then, transfer your laundry to the 7.6 cu. ft. dryer that easily adapts to both small and large loads for optimal fabric care.

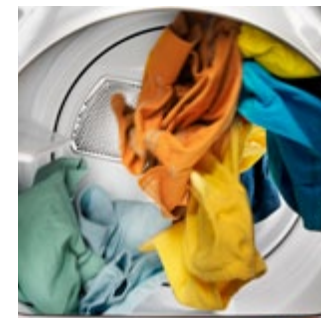

Stops drying when items are ready

Whirlpool brand brings high efficiency to the dryer with Advanced Moisture Sensing and the AccuDry™ and AccelerCare® sensor drying systems. HE Cabrio® dryers save time and energy by monitoring moisture levels and ending the cycle when everything is dry.

NOTE: Not all features are available on all models.

*Among leading top load brands, based on cleaning, gentleness and efficiency in the washer and lower fabric temperatures in the dryer. **Compared to other leading brand top load pairs, based on equal weighting of energy and water usage, using eco cycles/options. †Compared to a pre-2004 traditional washer and non-sensor dryer, based on normal cycle, average use, 11-year washer life, 12-year dryer life, electric dryers only. ††Among leading brand top load pairs, based on combined washer and dryer cu. ft.

Cabrio® HE Top Load Washers



WTW5500X 3.6 cu. ft. W

Recommended dryer: WE/GD5500X
 ENERGY STAR® qualified
 Meets CEE Tier 3* standards
 H₂Low™ wash system with Auto Load Sensing
 Precision Dispense
 Quiet Spin technology
 Stainless steel wash basket

RATED A
 BEST
 BUY™



WTW5600X 3.6 cu. ft. W

Recommended dryer: WE/GD5600X
Eco Monitor
EcoBoost™ option
Quiet Wash system
 ENERGY STAR® qualified
 Meets CEE Tier 3* standards
 H₂Low™ wash system with Auto Load Sensing
 Precision Dispense
 Quiet Spin technology
 Stainless steel wash basket

Cabrio® HE Top Load Dryers



WE/GD5500X 7.4 cu. ft. W

Recommended washer: WTW5500X
 AccuDry™ drying system
 90-minute Wrinkle Shield™ Plus option
 Drum light



WE/GD5600X 7.4 cu. ft. W

Recommended washer: WTW5600X
Eco Monitor
 150-minute Wrinkle Shield™ Plus option
Quiet Dry system
 AccuDry™ drying system
 Drum light

*Based on the Consortium for Energy Efficiency qualifying product lists. Visit cee1.org for more information. **According to a leading consumer magazine.

Step-up features
 highlighted by
 yellow bar



Most Whirlpool® washers
 are ENERGY STAR® qualified.

Feature descriptions can be found in the [glossary](#) on pages 220–221. Complete product specifications can be found on pages 226–227.

Cabrio® HE Top Load Washers

RATED A
BEST
BUY*



WTW5700X 3.6 cu. ft. W

Recommended dryer: WE/GD5700X

- Tempered glass lid
- ENERGY STAR® qualified
- Meets CEE Tier 3** standards
- Eco Monitor
- EcoBoost™ option
- H₂Low™ wash system with Auto Load Sensing
- Precision Dispense
- Quiet Spin technology
- Stainless steel wash basket
- Quiet Wash system

RATED A
BEST
BUY*



WTW5700A 3.6 cu. ft. C

Recommended dryer: WE/GD5700A

- ENERGY STAR® qualified
- Meets CEE Tier 3** standards
- Eco Monitor
- EcoBoost™ option
- H₂Low™ wash system with Auto Load Sensing
- Precision Dispense
- Quiet Spin technology
- Stainless steel wash basket
- Quiet Wash system
- Tempered glass lid

Cabrio® HE Top Load Dryers

WE/GD5700X 7.4 cu. ft. W

Recommended washer: WTW5700X

- AccelerCare® drying system
- Window
- Eco Normal cycle
- On/Off drum light
- Eco Monitor
- 150-minute Wrinkle Shield™ Plus option
- Quiet Dry system



WE/GD5700A 7.4 cu. ft. C

Recommended washer: WTW5700A

- AccelerCare® drying system
- Eco Monitor
- 150-minute Wrinkle Shield™ Plus option
- Quiet Dry system
- Window
- Eco Normal cycle
- On/Off drum light



*According to a leading consumer magazine. **Based on the Consortium for Energy Efficiency qualifying product lists. Visit cee1.org for more information.

Step-up features
highlighted by
yellow bar



Most Whirlpool® washers
are ENERGY STAR® qualified.

Feature descriptions can be found in the [glossary](#) on pages 220–221. Complete product specifications can be found on pages 226–227.

Cabrio® Platinum HE Top Load Washers



WTW8200Y 4.6 cu. ft. W

Recommended dryer: WE/GD8200Y

- Unique soft-touch impeller
- H₂Low™ wash system with Floating Basket Technology**
- Quiet Wash Plus system**
- ENERGY STAR® qualified
- Meets CEE Tier 3* standards
- Eco Monitor
- EcoBoost™ option
- Precision Dispense
- Quiet Spin technology
- Stainless steel wash basket



WTW8600Y 4.6 cu. ft. W

Recommended dryer: WE/GD8600Y

- Clean Care cycle**
- EasyView™ glass lid with slow-close hinge**
- Chrome accents
- ENERGY STAR® qualified
- Meets CEE Tier 3* standards
- Eco Monitor
- EcoBoost™ option
- Unique soft-touch impeller
- H₂Low™ wash system with Floating Basket Technology
- Precision Dispense
- Quiet Spin technology
- Stainless steel wash basket
- Quiet Wash Plus system

Cabrio® Platinum HE Top Load Dryers



WE/GD8200Y 7.6 cu. ft. W

Recommended washer: WTW8200Y

- Advanced Moisture Sensing**
- EcoBoost™ option**
- Eco Monitor
- 150-minute Wrinkle Shield™ Plus option
- Quiet Dry system
- Drum light



WE/GD8600Y 7.6 cu. ft. W

Recommended washer: WTW8600Y

- Steam-enhanced cycles**
- Window
- Chrome accents
- Advanced Moisture Sensing
- Eco Monitor
- EcoBoost™ option
- 150-minute Wrinkle Shield™ Plus option
- Quiet Dry system
- Drum light

*Based on the Consortium for Energy Efficiency qualifying product lists. Visit cee1.org for more information.

Step-up features highlighted by yellow bar



Most Whirlpool® washers are ENERGY STAR® qualified.

Feature descriptions can be found in the [glossary](#) on pages 220–221. Complete product specifications can be found on pages 228–229.

Cabrio® Platinum HE Top Load Washers



WTW8800Y 4.6 cu. ft. W | C

Recommended dryer: WE/GD8800Y

- Precision Dispense Plus
- Oxi Dispense option
- Water heater
- Interior LED light
- Clean Care cycle
- ENERGY STAR® qualified
- Meets CEE Tier 3* standards
- Eco Monitor
- EcoBoost™ option
- Unique soft-touch impeller
- H₂Low™ wash system with Floating Basket Technology
- Quiet Spin technology
- Stainless steel wash basket
- Quiet Wash Plus system
- EasyView™ glass lid with slow-close hinge
- Chrome accents

Cabrio® Platinum HE Top Load Dryers



WE/GD8800Y 7.6 cu. ft. W | C

Recommended washer: WTW8800Y

- 150-minute **Wrinkle Shield™ Plus option** with Steam
- Quiet Dry Plus system
- Advanced Moisture Sensing
- Eco Monitor
- EcoBoost™ option
- Steam-enhanced cycles
- Window
- Drum light
- Chrome accents

*Based on the Consortium for Energy Efficiency qualifying product lists. Visit cee1.org for more information.

Step-up features highlighted by yellow bar



Most Whirlpool® washers are ENERGY STAR® qualified.

Feature descriptions can be found in the [glossary](#) on pages 220–221. Complete product specifications can be found on pages 228–229.



WTW4950XW & WE/GD4900XW

TRADITIONAL TOP LOAD LAUNDRY

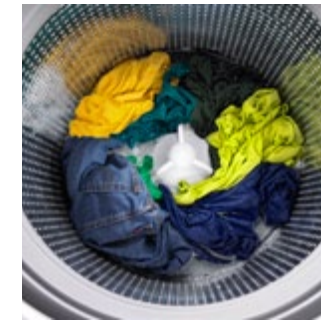

Saves money on utility bills

Top load washers that meet CEE Tier 3* standards and feature the H₂Low™ wash system save over 300 gallons of water per week** and more than \$1,400 in lifetime water and energy costs.† They also provide superior cleaning using less water by automatically sensing the size of each load.

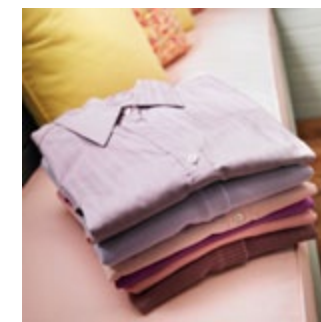

Cleans better using lower temperatures

Protect your wallet and the environment. The EcoBoost™ option uses a lower temperature to provide excellent cleaning while reducing your overall utility costs.



Tracks progress

All Whirlpool brand traditional washers let you clearly see which part of the cycle your washer is running, including Sensing, Wash, Rinse, Spin, Done and Lid Lock.

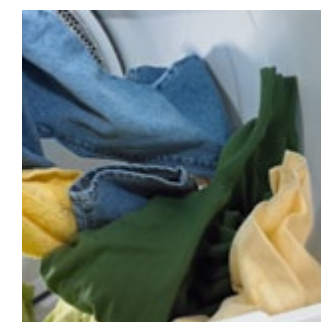

Uses less energy

The AccuDry™ drying system uses less energy than dryers equipped with the AutoDry™ system,†† helping to lower your monthly water and electric bills. The system reduces overdrying by monitoring moisture levels and temperatures.

NOTE: Not all features are available on all models.

*Based on the Consortium for Energy Efficiency qualifying product lists. Visit cee1.org for more information. **Compared to pre-2004 traditional top load washers using normal cycle. †Compared to pre-2004 traditional top load washers, based on average use, 11-year average life, model WTW4950X. ††Electric models only.

Traditional Top Load Washers



WTW4800X 3.4 cu. ft. Q
Recommended dryer: WE/GD4800X
Quiet Spin technology
Xtra Roll Action™ Plus agitator
Cycle status bar
On/Off Extra Rinse option



WTW4850X 3.4 cu. ft. Q
Recommended dryers: WE/GD4800X, WE/GD4850X
ENERGY STAR® qualified
Meets CEE Tier 1* standards
Wide open lid
Quiet Spin technology
Xtra Roll Action™ Plus agitator
Cycle status bar
On/Off Extra Rinse option

Traditional Top Load Dryers



WE/GD4800X 7.0 cu. ft. Q
Recommended washers: WTW4800X, WTW4850X
AutoDry™ drying system
40-minute Wrinkle Shield™ option
Drum light
Reversible side-swing door



WE/GD4850X 7.0 cu. ft. Q
Recommended washer: WTW4850X
On/Off 40-minute Wrinkle Shield™ option
Wide-opening hamper door
AutoDry™ drying system
Drum light

*Based on the Consortium for Energy Efficiency qualifying product lists. Visit cee1.org for more information.

Step-up features highlighted by yellow bar



Most Whirlpool® washers are ENERGY STAR® qualified.

Feature descriptions can be found in the [glossary](#) on pages 220–221. Complete product specifications can be found on pages 230–231.

Traditional Top Load Washers



- WTW4880A 3.4 cu. ft. W**
Recommended dryer: WE/GD4900X
- On/Off Deep Water Wash option
 - ENERGY STAR® qualified
 - Meets CEE Tier 1* standards
 - Quiet Spin technology
 - Xtra Roll Action™ Plus agitator
 - Cycle status bar
 - On/Off Extra Rinse option
 - Wide open lid



- WTW4950X 3.6 cu. ft. HIGH EFFICIENCY W**
Recommended dryer: WE/GD4900X
- H₂Low™ wash system with Auto Load Sensing
 - Stainless steel wash basket
 - Meets CEE Tier 3* standards
 - EcoBoost™ option
 - Impeller
 - ENERGY STAR® qualified
 - Quiet Spin technology
 - Cycle status bar
 - On/Off Extra Rinse option
 - Wide open lid

Traditional Top Load Dryers



- WE/GD4900X 7.0 cu. ft. HIGH EFFICIENCY W**
Recommended washers: WTW4880A, WTW4950X
- AccuDry™ drying system
 - On/Off 90-minute Wrinkle Shield™ option
 - Drum light
 - Wide-opening hamper door

*Based on the Consortium for Energy Efficiency qualifying product lists. Visit cee1.org for more information.

Step-up features highlighted by yellow bar



Most Whirlpool® washers are ENERGY STAR® qualified.

Feature descriptions can be found in the [glossary](#) on pages 220–221. Complete product specifications can be found on pages 230–231.

Laundry 1-2-3™ Pedestals

Laundry 1-2-3™ Pedestals



100 years of innovation built with American pride
Designed, engineered and assembled in the U.S.A.

Models: Duet® washer WFW96HEAW and Duet® dryer WE/GD96HEAW
with optional 15.5" pedestals XHPC155XW

Step-up features
highlighted by
yellow bar

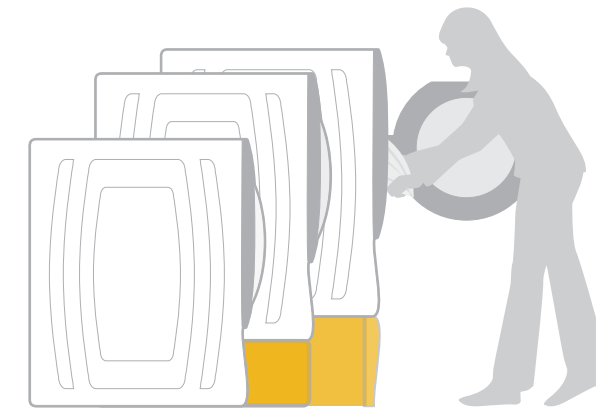

Using height as a guide,
choose the recommended
pedestal while also taking

	Recommended Pedestal
5'4" and up	12" or 15.5"
Under 5'4"	10"

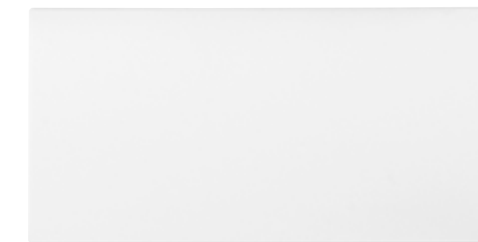

LAB0050P Q

12" Height
Recommended for compact laundry pairs

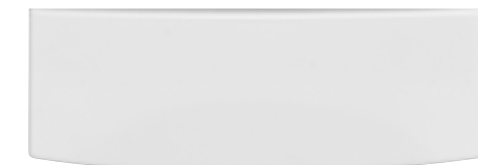

XHP1000X W

10" Height
Recommended for all front load laundry pairs



XHP1550V W XHP1550W L|R

15.5" Height
Storage drawer
Recommended for all front load laundry pairs



XHPC155X W|L|R XHPC155Y C|U

Chrome handle
15.5" Height
Storage drawer
Recommended front load laundry pairs:
WFW94HEA & WE/GD94HEA
WFW96HEA & WE/GD96HEA
WFW97HEX & WE/GD97HEX

Feature descriptions can be found in the [glossary](#) on pages 220–221. Complete product specifications can be found on page 235.

Thin Twin® Laundry Centers



LTE/G5243D Q

DRYER
3.4 cu. ft.
18 cycles / 4 temperatures

WASHER
1.5 cu. ft.
Surgilator® agitator
Tough Top™ II top and lid
5 cycles / 4 temperatures



WE/GT3300X Q

DRYER
5.9 cu. ft.
6 cycles / 3 temperatures

WASHER
2.5 cu. ft.
Two-piece Surgilator® agitator
8 cycles / 4 temperatures

Compact Laundry Pairs



WED7500V 3.8 cu. ft. W

DRYER
AutoDry™ drying system
Stainless steel dryer drum
Moisture Sensor control
Dryer stack kit included
11 cycles / 2 temperatures

WFC7500V 2.0 cu. ft. W

WASHER
ENERGY STAR® qualified
Meets CEE Tier 1* standards
Stainless steel wash drum
Cycle status bar
Estimated time remaining display
8 cycles / 3 temperatures



LER3622P 3.4 cu. ft. Q

DRYER
3 cycles / 2 temperatures

LDR3822P 3.4 cu. ft. Q

DRYER
AccuDry™ drying system
3 cycles / 2 temperatures

LCE4332P 2.1 cu. ft. Q

WASHER
Straight vane agitator
4 cycles / 3 temperatures

Shown with optional stack stand (49971)

Step-up features
highlighted by
yellow bar



Most Whirlpool® washers
are ENERGY STAR® qualified.

*Based on the Consortium for Energy Efficiency qualifying product lists. Visit cee1.org for more information.

Feature descriptions can be found in the [glossary](#) on pages 220–221. Complete product specifications can be found on pages 232–234.

Accessories



affresh® Washer Cleaner (W10135699)

Effectively remove odor-causing residue from your washer while cleaning mold and mildew stains, too. Includes three tablets.



Front Load Stack Kits 8541503 (Models: 9470W and 9550W) W10298318RP (Models: 94HEA, 96HEA and 97HEX)

Install a front load dryer on top of its matching washer with this stack kit.



Precision Dispense Ultra HE Detergent Dispenser (W10250743A)

Adds the right amount of detergent based on load size and soil level. Extra dispenser provides flexibility in changing detergent.



Compact Model Stack Stand (49971)

Install compact dryer model LER3622P on top of the LCE4332P compact washer model with this stack stand.



Front Load Dryer Door Reversal Kit All colors - 8579666ARP (Models: 9470W and 9550W)

Open your front load dryer from either the left or right side with this easy-to-use door reversal kit. (No kit needed for models 94HEA, 96HEA and 97HEX)



Dryer Lint Brush (8212614)

Extend dryer life, lower utility bills and reduce drying time by regularly and thoroughly removing lint with this cleaning brush.



Washable Delicates Bag (W10180464RP)

Protect delicate items from snags, tangles and tears while machine washing and drying.



Top Load Washer/Dryer Cover (W10214580RP)

Protect your top load washer or dryer from environmental damage with this gray cover. The cover also cleans easily with a damp cloth.



Industrial-Grade Washer Hoses 8212638RP: (2) 6' Nylon Braided w/90° elbow 8212487RP: (2) 5' Nylon Braided 8212545RP: (2) 5' Red & Blue EPDM 8212656RP: (2) 10' Black EPDM 8212546RP: (2) 4' Black EPDM 8212641RP: (2) 5' Black EPDM

Industrial strength hoses safely and efficiently transport hot and cold water to the washer.

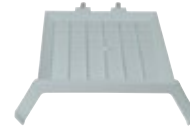

Dryer Racks W10322470A (Models: 94HEA, 96HEA and 97HEX) W10121663 (Models: 9470W and 9550W) 8212450A (Models: 5500X, 5600X, 5700X and 5700A) 3406839 (Model: 4800X)

The dryer rack is convenient for flat items such as sweaters and hats, or for bulky items like footwear and stuffed animals. A quick and easy insertion of this lightweight rack means tumble-free drying.



Laundry 1-2-3™ Adjustable Clothes Rack (XHS1000XX)

Hang garments straight from the washer or dryer with this clothes rack. It's also collapsible for quick, easy storage.

To acquire pricing information, order Whirlpool® laundry accessories and determine delivery time, visit whirlpool.com/accessories or call 1-800-462-3819.

Accessories

Optional Accessories

DRYER CORDS	
4', 3-wire, 30 amp	PT220L
4', 4-wire, 30 amp	PT400L
6', 4-wire, 30 amp	PT600L
Gas dryer connector kit	20-48KITRC

LP GAS CONVERSION KITS	
24" Thin Twin® laundry and compacts	49573 (10,500 BTU)
27" Thin Twin® laundry centers	3392235 (16,000 BTU)
Full-size gas dryers (lint screen on top)	49572 (22,000 BTU)
Duet® dryers (94HEA, 96HEA, 97HEX)	W10307153 (20,000 BTU)
Duet® dryers (lint screen front)	W10317689 (20,000 BTU)

WASHER ACCESSORIES	
(2) 5' Reinforced braid fill hoses (all washers)	8212487RP
2' Siphon break kit (27" & 29" washers)	285834
Drain reducer kit (29" washers)	40923
Floor drain kit (29" washers)	280129A
4' Drain extension kit (includes coupler, 2 clamps and 4' drain hose with fitted end)	DRNEXT4

Exhaust Information

All dryers require the equivalent of a 4-inch diameter exhaust duct. Whirlpool Corporation recommends using a rigid metal duct to minimize the risk of lint fires and melted venting.

27" & 29" DRYER VENTING REQUIREMENTS	4" HOOD (4396007RW)	4" HOOD (8212662)
Number of 90° turns	4"	4"
0	64' / 36"	64' / 36"
1	54' / 31"	54' / 31"
2	44' / 27"	44' / 27"
3	35' / 25"	35' / 25"
4	27' / 23"	27' / 23"

24" Compact long vent drying requirements (LEW0050P)

NUMBER OF 90° TURNS OR ELBOWS	TYPE OF VENT	BOX OR LOUVERED HOODS	ANGLED HOODS
0	Rigid metal / Flexible metal	90' (27.4 m) / 64' (19.5 m)	80' (24.4 m) / 58' (17.7 m)
1	Rigid metal / Flexible metal	80' (24.4 m) / 58' (17.7 m)	70' (21.3 m) / 52' (15.8 m)
2	Rigid metal / Flexible metal	70' (21.3 m) / 50' (15.2 m)	60' (18.3 m) / 42' (12.8 m)

8' DuraSafe™ Dryer Vent Installer's Kit (4396013RB)

Kit Contains:

- (1) 4' pipe section attached to (1) close elbow
- (1) 4' pipe section attached to (1) wall-offset elbow
- (1) Extension collar
- (2) Clamps for wall and dryer connection
- Installation instructions

*Refer to Use & Care Guide for specific model. **Maximum length of 4" diameter rigid metal duct and flexible metal duct.

Glossary

AccelerCare® drying system

Built-in sensor strips and computer intelligence combine to sense how fast the load is drying, how hot the air should be and when your clothes are dry, stopping the cycle automatically to help prevent overdrying and shrinking.

AccuDry™ drying system

Measures moisture and temperature levels to reduce overdrying and automatically stop the cycle when the load is dry. Dryers with the AccuDry™ system use less energy than Whirlpool® top load dryers equipped with the AutoDry™ system.*

Active Spray technology

Sprays the load with detergent in a cone shaped pattern to completely and evenly cover the fabrics.

Adaptive Clean wash system

Keeps clothes looking newer longer** by combining the right amount of wash action and detergent with the Care Control temperature management system.

Adaptive wash actions

Up to 16 different adaptive wash actions, from rocking to tumbling, adapt to the cleaning needs of each load. These adaptive wash actions provide a combination of powerful cleaning and gentle fabric care, handling everything from heavily soiled jeans to delicate silks.

Advanced Moisture Sensing

Whirlpool brand's most advanced drying system uses built-in sensors to read temperature and moisture levels, so the drying cycle can end when everything is thoroughly dry, saving time and energy.

Allergen cycle

Remove up to 95% of common allergens from your clothes with the Allergen cycle.† Select models feature an Allergen cycle certified by NSF International.

AutoDry™ drying system

Automatically senses when clothes have reached the right temperature and stops the cycle to save energy.

Care Control temperature management system

Adjusts the cold and hot water inlets to reach temperatures that are warm enough to dissolve detergents. Water is kept from overheating to help reduce shrinking and color bleeding.

CEE Tier standards

Based on the Consortium for Energy Efficiency (CEE) qualifying product lists—with Tier 3 being the most efficient. These models feature advanced water and energy savings and may qualify for rebates from local utility companies. Visit cee1.org for more information.

Clean Care cycle

Provides the best care for your clothes,†† using adaptive wash actions together with a concentrated solution of HE detergent and cold water to gently lift stains and soils from fabrics.

Clean Washer cycle with affresh® Washer cleaner

Deep-fills the washer to clean areas that low-water systems don't typically reach. All it takes is one cup of bleach. Using affresh® Washer cleaner also effectively eliminates odor-causing residue and cleans mold and mildew stains.

Deep Clean option

Penetrates deep into fabric fibers, breaking down and dissolving stains without pretreating. Select models add steam enhancement for even better cleaning.

Delay Wash

Sets the washer to begin cleaning up to 18 hours later, during off-peak hours when utility rates may be lower or when unloading the washer is more convenient.

Direct drive motor

Handles larger capacity loads, enhances the spin speed for improved energy savings and uses fewer moving parts so there's less wear and tear over time.

Direct Inject wash system

Automatically senses the size of each load to use just the right amount of water and deliver great cleaning. The system also delivers more gentle performance.

EasyView™ glass lid

A see-through glass lid allows you to look inside and see the wash action while the load is in progress. The frameless design also offers a larger viewable area. Select models also feature a Smooth Close lid that opens and closes easily without slamming.

EcoBoost™ option

In the washer, this option uses a lower temperature and increased spin speed or mechanical action to provide excellent cleaning and reduce your overall energy use. In the dryer, this option saves energy by using less heat and an increased cycle time.

Eco Monitor

Allows you to see how the cycles and options you choose will affect your overall energy savings in both the washer and the dryer.

Eco Normal cycle

Saves up to 40% dryer energy when paired with a matching Duet® or Cabrio® washer, compared to a traditional top load laundry pair.*

ENERGY STAR® qualified

Meets government standards to help conserve natural resources and save money on your utility bills.

FanFresh® option with Dynamic Venting Technology®

After the wash cycle, the FanFresh® option's built-in washer fan circulates air in the washer, keeping your clean clothes fresh and free from odors for up to 16 hours. When activated, select models will automatically tumble clothes for up to 12 hours. You can even wash and dry a small load right in the washer.‡

H₂Low™ wash system with Auto Load Sensing

High-efficiency top load washer models feature a wash system that uses less water per load while delivering better cleaning performance and gentleness than a traditional top load washer.

High efficiency (HE) sensor drying

Whirlpool brand brings high efficiency to the dryer with models featuring AccuDry™ and AccelerCare® sensor drying systems. Select models with Advanced Moisture Sensing also save energy and deliver the best care for your clothes†† by adjusting dry time and temperature as needed and stopping the cycle when clothes are dry.

Laundry Apps

The full-color widescreen LCD interface on select Duet® washers and dryers offers a full suite of Laundry Apps that includes Stain Assist, Hints & Tips and Before You Call. Up to 14 specialized washer and dryer cycles handle the most difficult jobs and can even be customized to best wash and dry the kinds of fabrics you launder most frequently.

NSF Certified sanitization cycles/options

Eliminate 99.9% of certain household bacteria.* Sanitization cycles and temperatures on Duet® washers add this benefit, while select Duet® Steam dryers also feature an NSF Certified Sanitize cycle.

Oxi Dispense option

Enhances whitening performance with an eco-friendly alternative to bleach. An automatic dispenser distributes the oxygenated additive at the appropriate time, sending oxygen through the load to brighten fabrics.

Precision Dispense

Penetrates stains and pretreats soils with a concentrated burst of detergent. The wash cycle begins only after the entire load has been treated. Plus models add the ability to release oxy additives while Ultra models can hold enough 2X concentration HE detergent for up to 12 loads of laundry in a single filling.

Quad dryer baffles

Four shorter, staggered baffles increase the effectiveness of the dryer and promote better, more even tumbling.

Quick Wash/Dry cycle

Designed to clean or dry small, lightly soiled loads in less time using increased spin speeds to extract more water. The Quick Dry cycle even allows you to finish drying a load in as little as 13 minutes.

Quiet Spin technology

Install your laundry pair on a second floor and be assured of great out-of-balance performance and vibration control. Quiet Spin 360 technology's dual-ring ball-balancing system makes it our highest level of vibration control.

Glossary

Quiet Wash/Dry noise reduction systems

Keep operational sounds inside the washer and dryer and out of living areas with sound-absorbing materials around the wash basket and dryer drum. Escalating levels of sound reduction are available, up to Quiet Wash Ultra and Quiet Dry Ultra.

Reduce Static/Static Reduce option

Uses tumbling and a spray mist in the dryer to evenly reduce the amount of static in an entire load of clothes.

SilentSteel™ dryer drum

Forget about the sound of metal buttons and zippers making noise as they tumble, thanks to a unique sound-dampening material that surrounds the stainless steel dryer drum. The dryer runs quieter, even when you load items with metal accents.

Stainless steel washer and dryer drum

The drum's stainless steel construction has a smooth surface that resists odors, rust and chipping and helps prevent fabrics from snagging or tearing.

Steam technology

In the washer, steam breaks down and dissolves tough stains without pretreating. In the dryer, features like the Enhanced Touch Up Steam cycle and Quick Refresh Steam cycle combine mist with heat to create steam to relax wrinkles and refresh dry clothes. Whirlpool® steam dryers also feature a Y-connector so you don't have to add water manually before starting a steam cycle.

Tap Touch controls

Allows direct access to washer and dryer functions, and its sleek appearance enhances the appeal of any space.

TumbleFresh™ option

Activates after the wash cycle is finished and rolls clean clothes periodically to help prevent wrinkles from setting in. Clothes stay fresh without having to transfer them to the dryer immediately.††

Wrinkle Shield™/Wrinkle Shield™ Plus option

Tumbles the dryer every 5 minutes after the cycle is complete to help prevent wrinkles from setting into clean, dry fabrics. The intermittent tumbling can continue for up to 150 minutes (based on the model), or until the door is opened and the load is removed. Select dryer models add steam to the tumbling for improved results.

Xtra Roll Action™ Plus agitator

Brings your laundry to the bottom of the wash basket where cleaning takes place. It can effectively roll over and clean twice the average size load (based upon a 7-lb average load size).

*Electric models only. **Compared to traditional top load washers. †Allergens tested were dust mites and pet dander.

††Among leading top load brands, based on cleaning, gentleness, and efficiency. ‡Based on a 2-lb load of lightweight fabrics.

‡‡Among leading top load brands, based on advanced sensor drying and lower fabric temperatures in the dryer. †Bacteria tested were *K. pneumonia*, *P. aureginosa* and *S. aureus*.

††Intermittent tumbling in the washer helps reduce the growth of odor-causing bacteria.

Duet® HE Front Load Washers

SPECIFICATIONS AND DIMENSIONS

WASHER MODEL RECOMMENDED DRYER	WHIRLPOOL®		
	WFW9151Y WE/GD9151Y	WFW9351Y WE/GD9371Y	WFW9550W WE/GD9550W
Capacity (cu. ft.)	3.5	3.5	3.8
High efficiency washer	•	•	•
ENERGY STAR® qualified	•	•	•
Meets CEE Tier standards*	Tier 3	Tier 3	Tier 3
Water use/Energy use**	76% less / 77% less	76% less / 77% less	76% less / 80% less
Estimated time remaining LED display	•	•	•
Eco Monitor	•	•	•
Add-a-Garment indicator	•	•	•
Adjustable end-of-cycle signal	On/Off	On/Off	Loud/Soft/Off
Stainless steel wash drum	•	•	•
Water heater	•	•	•
WASH SYSTEM			
Direct Inject wash system	•	•	•
Adaptive wash actions	8	10	11
Precision Dispense	•	•	•
Automatic dispensers	Detergent, bleach, fabric softener	Detergent, bleach, fabric softener	Detergent, bleach, fabric softener
Care Control temperature management system	•	•	•
Smooth Spin™ technology	•	•	•
Quiet Spin technology	•	•	•
Quiet Wash system	•	•	Plus
Deep Clean wash system	•	•	•
Max spin speed (RPM)	up to 1,200	up to 1,200	up to 1,300
Total number of temperatures	3	4	4
CYCLES AND OPTIONS			
Total number of cycles	12	13	12
Steam-enhanced cycles	•	•	•
Quick Wash cycle	•	•	•
Hand Washable cycle	•	•	•
Silk cycle	•	•	•
Delicate cycle	•	•	•
Small Load cycle	•	•	•
Active Wear cycle	•	•	•
Cold Wash cycle	•	•	•
Bulky Items cycle	•	•	•
Heavy Duty cycle	•	•	•
Whitest Whites cycle	•	•	•
NSF Certified Allergen cycle	•	•	•
NSF Certified Sanitize options	•	•	•
Clean Washer cycle with affresh® Washer cleaner	•	•	Integrated with Steam
EcoBoost™ option	•	•	•
TumbleFresh™ option	•	•	•
NightQuiet™ option	•	•	•
Deep Clean Steam option	•	•	•
Extra Rinse option	•	•	•
Delay Wash option	up to 10 hours	up to 15 hours	up to 12 hours
ACCESSORIES			
5' Black Washer Inlet Hose kit (2-pack)	8212641RP	8212641RP	8212641RP
5' Nylon Braided Washer Fill Hose kit (2-pack)	8212487RP	8212487RP	8212487RP
6' Gooseneck Nylon Braided Fill Hose kit (2-pack)	8212638RP	8212638RP	8212638RP
10' Washer Inlet Hose kit (2-pack)	8212656RP	8212656RP	8212656RP
Washer drip tray	8212526	8212526	8212526
DIMENSIONS AND COLORS			
Max height (A)	36"	36"	38"
Width (B)	27"	27"	27"
Depth (C)	30 1/2"	30 1/2"	32"
Depth with door open (D)	50 1/2"	50 1/2"	51"
Available colors	W	W	W L

Bold type indicates a step-up feature

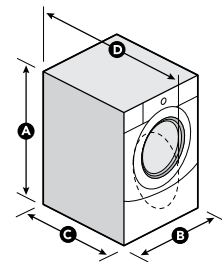

DIMENSIONS ARE SHOWN FOR PLANNING PURPOSES ONLY. For complete information, see Installation instructions packed with product.

*Based on the Consortium for Energy Efficiency qualifying product lists. Visit cee1.org for more information.
** Compared to pre-2004 traditional top load washers.

Duet® HE Front Load Dryers

SPECIFICATIONS AND DIMENSIONS

DRYER MODEL RECOMMENDED WASHER	WHIRLPOOL®			
	WED9151Y WGD9151Y WFW9151Y	WED9371Y WGD9371Y WFW9351Y	WED9550W WGD9550W WFW9550W	WED9470W WGD9470W
Capacity (cu. ft.)	6.7	6.7	7.2	7.2
High efficiency dryer	•	•	•	•
Estimated time remaining LED display	•	•	•	•
Dryer drum	Painted steel	Painted steel	Painted steel	Painted steel
Damp Dry signal	•	•	•	•
Adjustable end-of-cycle signal	On/Off	On/Off	Loud/Soft/Off	Loud/Soft/Off
DRYING SYSTEM				
AccelerCare® drying system	•	•	•	•
Quiet Dry system	•	•	Plus	Plus
Timed dry	•	•	•	•
4-way venting	•	•	•	•
Total number of temperatures	5	5	5	5
CYCLES AND OPTIONS				
Total number of cycles	9	9	12	12
Steam-enhanced cycles	•	•	•	•
Quick Dry cycle	•	•	•	•
Damp Dry cycle	•	•	•	•
Super Delicate cycle	•	•	•	•
Delicate cycle	•	•	•	•
Casual cycle	•	•	•	•
Eco Normal cycle	•	•	•	•
Normal cycle	•	•	•	•
Bulky Items cycle	•	•	•	•
Heavy Duty cycle	•	•	•	•
NSF Certified Sanitize cycle	•	•	•	•
Quick Refresh Steam cycle	•	•	•	•
Enhanced Touch Up Steam cycle	•	•	•	•
Wrinkle Shield™ Plus option	•	•	•	•
Wrinkle Shield™ option	up to 90 minutes	up to 90 minutes	up to 140 minutes	up to 140 minutes
ACCESSORIES				
Dryer rack	W10121663	W10121663	W10121663	W10121663
Duet® Laundry Pair Stack kit	8572546	8572546	8541503	8541503
Duet® Dryer Door Reversal kit	•	•	8579666ARP	8579666ARP
Door reversal instructions and hinge sticker	W10277499	W10277499	•	•
4-Way Internal Vent Kit Back (standard), left/right/bottom, universal color midnight grey	W10470674	W10470674	W10470674	W10470674
LP Gas Conversion kit	W10317689	W10317689	W10317689	W10317689
4' Gas Dryer Hook-Up kit	20-48KITRC	20-48KITRC	20-48KITRC	20-48KITRC
4', 3-wire, 30 amp dryer cord	PT220L	PT220L	PT220L	PT220L
4', 4-wire, 30 amp dryer cord	PT400L	PT400L	PT400L	PT400L
6', 3-wire, 30 amp dryer cord	PT500L	PT500L	PT500L	PT500L
6', 4-wire, 30 amp dryer cord	PT600L	PT600L	PT600L	PT600L
DIMENSIONS AND COLORS				
Max height (A)	36"	36"	38"	38"
Width (B)	27"	27"	27"	27"
Depth (C)	29"	29"	32 1/8"	32 1/8"
Depth with door open (D)	48 1/8"	48 1/8"	52 1/8"	52 1/8"
Available colors	W	W	W L	W

Bold type indicates a step-up feature

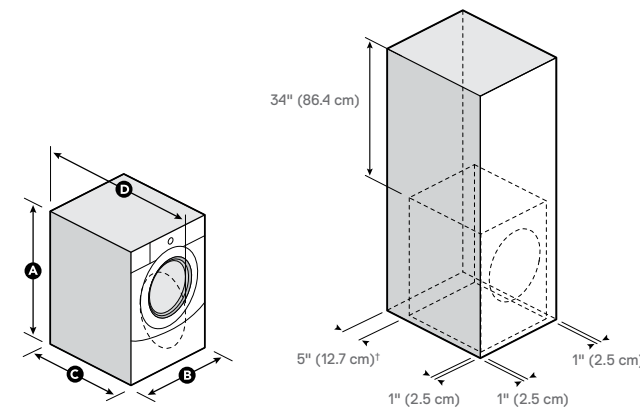

†Add 5-1/2" for proper venting of gas dryers.

Duet® HE Front Load Washers

SPECIFICATIONS AND DIMENSIONS

WASHER MODEL RECOMMENDED DRYER	WHIRLPOOL®			
	WFW88HEA WE/GD88HEA	WFW94HEA WE/GD94HEA	WFW96HEA WE/GD96HEA	WFW97HEX WE/GD97HEX
New 2012 model	-	-	-	-
Capacity (cu. ft.)	4.3	4.3	4.3	4.3
High efficiency washer	-	-	-	-
ENERGY STAR® qualified	-	-	-	-
Meets CEE Tier standards*	Tier 3	Tier 3	Tier 3	Tier 3
Water use/Energy use**	83% less / 85% less	83% less / 85% less	83% less / 85% less	82% less / 81% less
Tap Touch controls	♦	-	-	-
Estimated time remaining display	LED	LED	LED	Full-color widescreen LCD
Laundry Apps	-	-	-	Stain Assist, Hints & Tips, Before You Call
Add-a-Garment indicator	-	-	-	-
Adjustable end-of-cycle signal	-	-	-	Loud/Soft/Off
LED basket light	On/Off	On/Off	On/Off	On/Off
Stainless steel wash drum	-	-	-	-
Water heater	♦	-	-	-
WASH SYSTEM				
Active Spray technology	-	-	-	♦
Wash system	Adaptive Clean	Adaptive Clean	Adaptive Clean	Direct Inject
Adaptive wash actions	14	14	16	16
Precision Dispense	-	-	Ultra	Ultra
Automatic dispensers	Detergent, bleach, fabric softener	Detergent, bleach, fabric softener	Bulk detergent, bleach, fabric softener	Bulk detergent, bleach, fabric softener
Care Control temperature management system	-	-	-	-
Quiet Spin 360 technology	♦	-	-	-
Quiet Wash Ultra system	♦	-	-	-
Max spin speed (RPM)	up to 1,400	up to 1,400	up to 1,400	up to 1,400
Total number of temperatures	4	5	5	6
Suds sensor	♦	-	-	-
CYCLES AND OPTIONS				
Total number of cycles	11	12	12	12 (14 specialty)
Steam-enhanced cycles	-	-	-	-
My cycle	-	-	-	♦
Wash and Dry cycle	-	♦	-	-
Quick Wash cycle	-	-	-	-
Delicate cycle	-	-	-	-
Cold Wash cycle	♦	-	-	-
Whites cycle	-	-	-	-
Heavy Duty cycle	-	-	-	-
Towels cycle	♦	-	-	-
NSF Certified Allergen cycle	-	-	-	-
NSF Certified Sanitize cycle with steam	♦	-	-	-
Hand Wash cycle	-	-	-	♦
Bulky Items cycle	-	-	-	♦
Jeans cycle	-	-	-	♦
Clean Washer cycle with affresh® Washer cleaner	-	-	-	Integrated with Steam
NSF Certified Sanitize options	-	-	-	with Steam
EcoBoost™ option	with Eco Monitor	with Eco Monitor	-	-
TumbleFresh™ option	-	-	-	-
FanFresh® option with Dynamic Venting Technology®	-	12-hour	12-hour	16-hour
Deep Clean option	with Steam	with Steam	with Steam	with Steam
Delay Wash option	up to 12 hours	up to 12 hours	up to 12 hours	up to 20 hours
Presoak option	♦	-	-	-
ACCESSORIES				
Washer detergent cartridge	-	-	W10250743A	W10250743A
5' Washer Inlet Hose kit (2 pack)	8212641RP	8212641RP	8212641RP	8212641RP
Washer drip tray	8212526	8212526	8212526	8212526
DIMENSIONS AND COLORS				
Max height (A)	38"	38"	38"	38"
Width (B)	27"	27"	27"	27"
Depth (C)	32 1/4"	32 1/4"	32 1/4"	32 1/4"
Depth with door open (D)	52 1/4"	52 1/4"	52 1/4"	52 1/4"
Available colors	W C	W C	W C U	W L

Bold type indicates a step-up feature

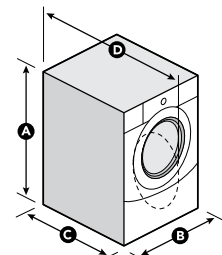

DIMENSIONS ARE SHOWN FOR PLANNING PURPOSES ONLY. For complete information, see Installation instructions packed with product.

*Based on the Consortium for Energy Efficiency qualifying product lists. Visit cee1.org for more information.
** Compared to pre-2004 traditional top load washers.

Duet® HE Front Load Dryers

SPECIFICATIONS AND DIMENSIONS

DRYER MODEL RECOMMENDED WASHER	WHIRLPOOL®			
	WED88HEA WGD88HEA	WED94HEA WGD94HEA	WED96HEA WGD96HEA	WED97HEX WGD97HEX
New 2012 model	-	-	-	-
Capacity (cu. ft.)	7.4	7.4	7.4	7.4
High efficiency dryer	-	-	-	-
Tap Touch controls	♦	-	-	-
Estimated time remaining LED display	-	-	-	Full-color widescreen LCD
Eco Monitor	♦	-	-	-
Laundry Apps	-	-	-	Hints & Tips, Before You Call
Damp Dry signal	Loud/Soft/Off	Loud/Soft/Off	Loud/Soft/Off	Loud/Soft/Off
Adjustable end-of-cycle signal	-	-	-	Loud/Soft/Off
Dryer drum	Stainless steel	Stainless steel	SilentSteel™	SilentSteel™
LED drum light	♦	-	-	-
Quad dryer baffles	♦	-	-	-
DRYING SYSTEM				
Advanced Moisture Sensing	♦	-	-	-
Quiet Dry system	Ultra	Ultra	Ultra	Ultra
Timed dry	-	-	-	-
Total number of temperatures	5	5	5	6
CYCLES AND OPTIONS				
Total number of cycles	10	10	10	12 (14 specialty)
Steam-enhanced cycles	-	-	-	-
My cycle	-	-	-	♦
Quick Dry cycle	-	-	-	-
Delicate cycle	-	-	-	-
Casual cycle	-	-	-	-
Bulky Items cycle	-	-	-	-
Jeans cycle	-	-	-	♦
Heavy Duty cycle	-	-	-	-
Towels cycle	♦	-	-	-
Sanitize cycle	♦	-	-	-
Enhanced Touch Up Steam cycle	-	-	-	♦
Steam Refresh cycle	-	-	-	Adjustable
EcoBoost™ option	♦	-	-	-
Wrinkle Shield™ Plus option	up to 140 minutes with Steam	up to 140 minutes with Steam	up to 140 minutes with Steam	up to 140 minutes with Steam
Static Reduce option	-	♦	-	-
ACCESSORIES				
Dryer rack	W10322470A	W10322470A	W10322470A	W10322470A
Duet® Stack kit	W10298318RP	W10298318RP	W10298318RP	W10298318RP
4-Way Internal Vent Kit Back (standard), left/right/bottom, universal color midnight grey	W10323246	W10323246	W10323246	W10323246
LP Gas Conversion kit	W10307153	W10307153	W10307153	W10307153
4" Gas Dryer Hook-Up kit	20-48KITRC	20-48KITRC	20-48KITRC	20-48KITRC
4', 3-wire, 30 amp dryer cord	PT220L	PT220L	PT220L	PT220L
4', 4-wire, 30 amp dryer cord	PT400L	PT400L	PT400L	PT400L
6', 3-wire, 30 amp dryer cord	PT500L	PT500L	PT500L	PT500L
6', 4-wire, 30 amp dryer cord	PT600L	PT600L	PT600L	PT600L
DIMENSIONS AND COLORS				
Max height (A)	38 1/4"	38 1/4"	38 1/4"	38 1/4"
Width (B)	27"	27"	27"	27"
Depth (C)	31"	31"	31"	31"
Depth with door open (D)	51"	51"	51"	51"
Available colors	W C	W C	W C U	W L

Bold type indicates a step-up feature

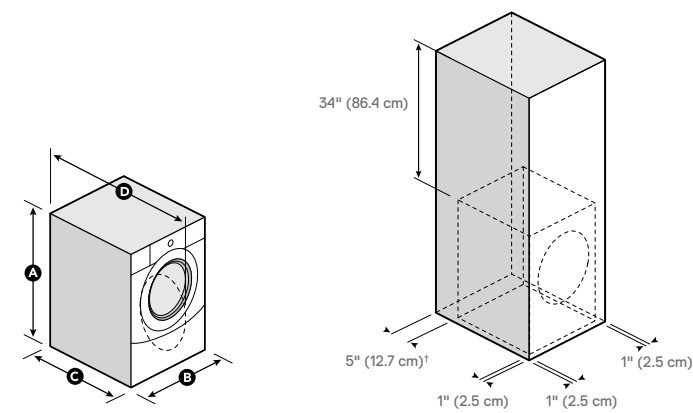

†Add 5-1/2" for proper venting of gas dryers.

Cabrio® HE Top Load Washers

SPECIFICATIONS AND DIMENSIONS

WASHER MODEL RECOMMENDED DRYER	WHIRLPOOL®			
	WTW5500X WE/GD5500X	WTW5600X WE/GD5600X	WTW5700X WE/GD5700X	WTW5700A WE/GD5700A
Capacity (cu. ft.)	3.6	3.6	3.6	3.6
High efficiency washer	-	-	-	-
ENERGY STAR® qualified	-	-	-	-
Meets CEE Tier standards*	Tier 3	Tier 3	Tier 3	Tier 3
Water use/Energy use**	74% less / 76% less	73% less / 76% less	73% less / 77% less	73% less / 77% less
Estimated time remaining LED display	-	♦	-	-
Eco Monitor	-	♦	-	-
Add-a-Garment indicator	-	-	-	-
Adjustable end-of-cycle signal	-	On/Off	Loud/Soft/Off	Loud/Soft/Off
Tempered glass lid	-	-	♦	-
Stainless steel wash basket	-	-	-	-
WASH SYSTEM				
H ₂ Low™ wash system with Auto Load Sensing	-	-	-	-
Adaptive wash actions	5	5	5	5
Precision Dispense	-	-	-	-
Automatic dispensers	Detergent, bleach, fabric softener	Detergent, bleach, fabric softener	Detergent, bleach, fabric softener	Detergent, bleach, fabric softener
Care Control temperature management system	-	-	-	-
Quiet Spin technology	-	-	-	-
Quiet Wash system	-	♦	-	-
Max spin speed (RPM)	up to 800	up to 800	up to 800	up to 800
Total number of temperatures	4	5	5	5
CYCLES AND OPTIONS				
Total number of cycles	9	11	11	11
Delicate cycle	-	-	-	-
Quick Wash cycle	-	-	-	-
Bulky Items cycle	-	-	-	-
Heavy Duty cycle	-	-	-	-
Clean Washer cycle with affresh® Washer cleaner	-	-	-	-
EcoBoost™ option	-	♦	-	-
Deep Clean option	-	-	♦	-
Delay Wash option	-	-	up to 9 hours	up to 9 hours
ACCESSORIES				
5' Washer Inlet Hose kit (2-pack)	8212641RP	8212641RP	8212641RP	8212641RP
5' Nylon Braided Washer Fill Hose kit (2-pack)	8212487RP	8212487RP	8212487RP	8212487RP
6' Gooseneck Nylon Braided Fill Hose kit (2-pack)	8212638RP	8212638RP	8212638RP	8212638RP
10' Washer Inlet Hose kit (2-pack)	8212656RP	8212656RP	8212656RP	8212656RP
Washer drip tray	8212526	8212526	8212526	8212526
DIMENSIONS AND COLORS				
Max height (A)	43 1/2"	43 1/2"	43 1/2"	43 1/2"
Width (B)	27 1/4"	27 1/4"	27 1/4"	27 1/4"
Depth (C)	26 3/8"	26 3/8"	26 3/8"	26 3/8"
Height with lid open (D)	53 3/8"	53 3/8"	53 3/8"	53 3/8"
Top height (E)	36 3/8"	36 3/8"	36 3/8"	36 3/8"
Available colors	W	W	W	C

Bold type indicates a step-up feature

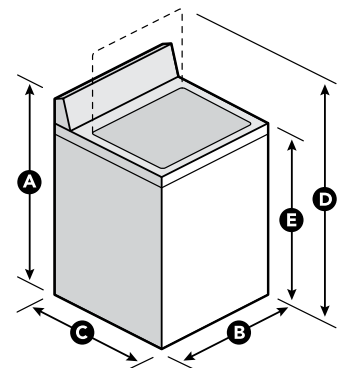

DIMENSIONS ARE SHOWN FOR PLANNING PURPOSES ONLY. For complete information, see Installation instructions packed with product.

*Based on the Consortium for Energy Efficiency qualifying product lists. Visit cee1.org for more information.
**Compared to pre-2004 traditional top load washers.

Cabrio® HE Top Load Dryers

SPECIFICATIONS AND DIMENSIONS

DRYER MODEL RECOMMENDED WASHER	WHIRLPOOL®			
	WED5500X WGD5500X	WED5600X WGD5600X	WED5700X WGD5700X	WED5700A WGD5700A
Capacity (cu. ft.)	7.4	7.4	7.4	7.4
High efficiency dryer	-	-	-	-
Estimated time remaining LED display	-	♦	-	-
Eco Monitor	-	♦	-	-
Damp Dry signal	-	♦	-	-
Adjustable end-of-cycle signal	On/Off	Loud/Soft/Off	Loud/Soft/Off	Loud/Soft/Off
Interior drum light	-	-	On/Off	On/Off
Dryer window	-	-	♦	-
DRYING SYSTEM				
AccuDry™ drying system	-	-	-	-
AccelerCare® drying system	-	-	♦	-
Quiet Dry system	-	♦	-	-
4-way venting	-	-	-	-
Total number of temperatures	4	5	5	5
CYCLES AND OPTIONS				
Total number of cycles	10	8	8	8
Eco Normal cycle	-	-	♦	-
Wrinkle Shield™ Plus option	up to 90 minutes	up to 150 minutes	up to 150 minutes	up to 150 minutes
ACCESSORIES				
Dryer rack	8212450A	8212450A	8212450A	8212450A
4-Way Internal Vent Kit Back (standard), left/right/bottom, universal color midnight grey	W10470674	W10470674	W10470674	W10470674
LP Gas Conversion kit	W10317689	W10317689	W10317689	W10317689
4' Gas Dryer Hook-Up kit	20-48KITRC	20-48KITRC	20-48KITRC	20-48KITRC
4', 3-wire, 30 amp dryer cord	PT220L	PT220L	PT220L	PT220L
4', 4-wire, 30 amp dryer cord	PT400L	PT400L	PT400L	PT400L
6', 3-wire, 30 amp dryer cord	PT500L	PT500L	PT500L	PT500L
6', 4-wire, 30 amp dryer cord	PT600L	PT600L	PT600L	PT600L
DIMENSIONS AND COLORS				
Max height (A)	43 1/2"	43 1/2"	43 1/2"	43 1/2"
Width (B)	27 1/4"	27 1/4"	27 1/4"	27 1/4"
Depth (C)	29 1/2"	29 1/2"	29 1/2"	29 1/2"
Depth with door open (D)	43 1/4"	43 1/4"	43 1/4"	43 1/4"
Top height (E)	36 3/8"	36 3/8"	36 3/8"	36 3/8"
Available colors	W	W	W	C

Bold type indicates a step-up feature

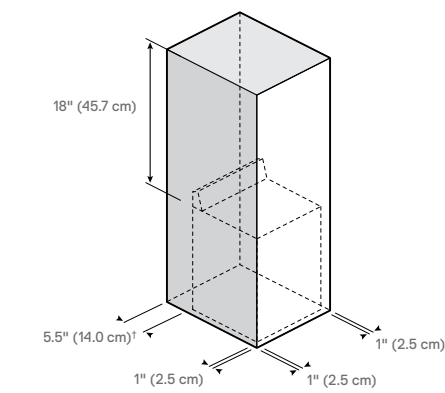
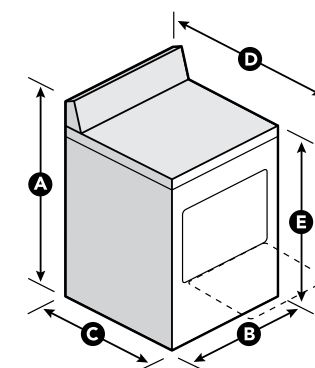

†Add 5-1/2" for proper venting of gas dryers.

Cabrio® Platinum HE Top Load Washers

SPECIFICATIONS AND DIMENSIONS

WASHER MODEL RECOMMENDED DRYER	WHIRLPOOL®		
	WTW8200Y WE/GD8200Y	WTW8600Y WE/GD8600Y	WTW8800Y WE/GD8800Y
New 2012 model	-	-	-
Capacity (cu. ft.)	4.6	4.6	4.6
High efficiency washer	-	-	-
ENERGY STAR® qualified	-	-	-
Meets CEE Tier standards*	Tier 3	Tier 3	Tier 3
Water use/Energy use**	75% less / 79% less	75% less / 79% less	75% less / 79% less
Eco Monitor	-	-	-
Add-a-Garment indicator	-	-	-
Adjustable end-of-cycle signal	-	-	-
Tempered glass lid	-	EasyView™ glass with slow-close hinge	EasyView™ glass with slow-close hinge
Interior LED light	-	-	On/Off
Stainless steel wash basket	-	-	-
Chrome accents	-	-	-
WASH SYSTEM			
H ₂ O™ wash system with Floating Basket Technology	-	-	-
Adaptive wash actions	11	11	11
Precision Dispense	-	-	Plus
Automatic dispensers	Detergent, bleach, fabric softener	Detergent, bleach, fabric softener	Detergent, oxi/bleach , fabric softener
Care Control temperature management system	-	-	-
Quiet Spin technology	-	-	-
Quiet Wash system	Plus	Plus	Plus
Max spin speed (RPM)	up to 1,100	up to 1,100	up to 1,100
NEW! Unique soft-touch impeller	-	-	-
Direct-drive motor	-	-	-
Total number of temperatures	3	4	5
Water heater	-	-	-
CYCLES AND OPTIONS			
Total number of cycles	11	13	16
NEW! Clean Care cycle	-	-	-
NSF Certified Sanitary cycle	-	-	with oxi
Active Wear cycle	-	-	-
Allergen cycle	-	-	-
Delicate/Handwash cycle	-	-	-
Quick Wash cycle	-	-	-
Bulky Items cycle	-	-	-
Deep Water Soak cycle	-	-	-
Soak cycle	-	-	-
Clean Washer cycle with affresh® Washer cleaner	-	-	-
EcoBoost™ option	-	-	-
Oxi Dispense option	-	-	-
Deep Clean option	-	-	with heater
Delay Wash option	up to 8 hours	up to 10 hours	up to 12 hours
ACCESSORIES			
5' Washer Inlet Hose kit (2-pack)	8212641RP	8212641RP	8212641RP
5' Nylon Braided Washer Fill Hose kit (2-pack)	8212487RP	8212487RP	8212487RP
6' Gooseneck Nylon Braided Fill Hose kit (2-pack)	8212638RP	8212638RP	8212638RP
10' Washer Inlet Hose kit (2-pack)	8212656RP	8212656RP	8212656RP
Washer drip tray	8212526	8212526	8212526
DIMENSIONS AND COLORS			
Max height (A)	45 1/2"	45 1/2"	45 1/2"
Width (B)	27 1/2"	27 1/2"	27 1/2"
Depth (C)	27 1/2"	27 1/2"	27 1/2"
Height with lid open (D)	58"	58"	58"
Top height (E)	39"	39"	39"
Available colors	W	W	W C

Bold type indicates a step-up feature

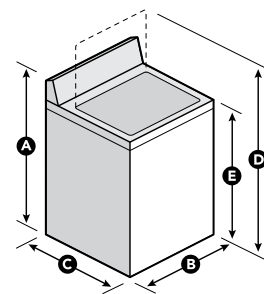

*Based on the Consortium for Energy Efficiency qualifying product lists. Visit cee1.org for more information.
**Compared to pre-2004 traditional top load washers.

DIMENSIONS ARE SHOWN FOR PLANNING PURPOSES ONLY. For complete information, see Installation instructions packed with product.

Cabrio® Platinum HE Top Load Dryers

SPECIFICATIONS AND DIMENSIONS

DRYER MODEL RECOMMENDED WASHER	WHIRLPOOL®		
	WED8200Y WGD8200Y WTW8200Y	WED8600Y WGD8600Y WTW8600Y	WED8800Y WGD8800Y WTW8800Y
New 2012 model	-	-	-
Capacity (cu. ft.)	7.6	7.6	7.6
High efficiency dryer	-	-	-
Eco Monitor	-	-	-
Damp Dry signal	On/Off	On/Off	On/Off
Adjustable end-of-cycle signal	On/Off	Loud/Soft/Off	Loud/Soft/Off
Check vent indicator	-	-	-
Interior drum light	-	-	-
Dryer window	-	-	-
Chrome accents	-	-	-
DRYING SYSTEM			
Advanced Moisture Sensing	-	-	-
Quiet Dry system	-	-	Plus
Venting options	2-way	2-way	2-way
Dual heating element	-	-	-
Y connector	-	-	-
Total number of temperatures	5	5	5
CYCLES AND OPTIONS			
Total number of cycles	9	11	14
Steam-enhanced cycles	-	-	-
Quick Refresh cycle	-	-	with Steam
Enhanced Touch Up cycle	-	with Steam	with Steam
Quick Dry cycle	-	-	-
Active Wear cycle	-	-	-
Sanitize cycle	-	-	-
Delicate cycle	-	-	-
Sheets cycle	-	-	-
Jeans cycle	-	-	-
Towels cycle	-	-	-
Heavy Duty cycle	-	-	-
EcoBoost™ option	-	-	-
Wrinkle Shield™ Plus option	up to 150 minutes	up to 150 minutes	up to 150 minutes with Steam with Steam
Static Reduce option	-	-	-
ACCESSORIES			
Dryer rack	8577312A	8577312A	8577312A
LP Gas Conversion kit	W10317689	W10317689	W10317689
4' Gas Dryer Hook-Up kit	20-48KITRC	20-48KITRC	20-48KITRC
4', 3-wire, 30 amp dryer cord	PT220L	PT220L	PT220L
4', 4-wire, 30 amp dryer cord	PT400L	PT400L	PT400L
6', 3-wire, 30 amp dryer cord	PT500L	PT500L	PT500L
6', 4-wire, 30 amp dryer cord	PT600L	PT600L	PT600L
DIMENSIONS AND COLORS			
Max height (A)	45 1/2"	45 1/2"	45 1/2"
Width (B)	29"	29"	29"
Depth (C)	29 1/2"	29 1/2"	29 1/2"
Depth with door open (D)	52 1/4"	52 1/4"	52 1/4"
Top height (E)	39"	39"	39"
Available colors	W	W	W C

Bold type indicates a step-up feature

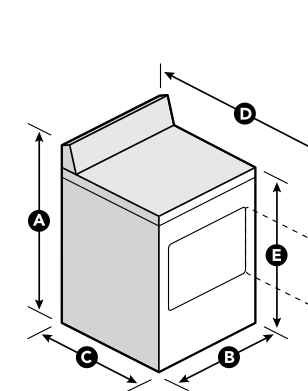

†Add 5-1/2" for proper venting of gas dryers.

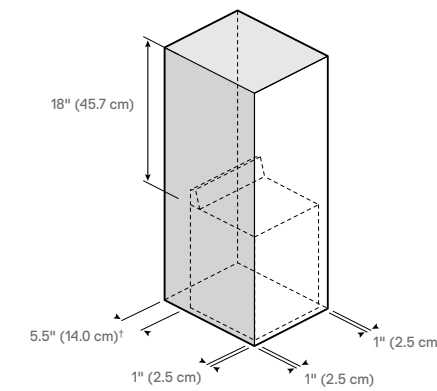

Traditional Top Load Washers

SPECIFICATIONS AND DIMENSIONS

WASHER MODEL	WHIRLPOOL®			
	WTW4800X WE/GD4800X WE/GD4850X	WTW4850X WE/GD4850X	WTW4880A WE/GD4900X	WTW4950X WE/GD4900X
Capacity (cu. ft.)	3.4	3.4	3.4	3.6
High efficiency washer		♦	♦	♦
ENERGY STAR® qualified		♦	♦	♦
Meets CEE Tier standards*		Tier 1	Tier 1	Tier 3
Water use/Energy use**		60% less / 77% less	60% less / 77% less	74% less / 76% less
Cycle status bar	♦	♦	♦	♦
Wide open top and lid		♦	♦	♦
Wash basket	White porcelain	White porcelain	White porcelain	Stainless steel
WASH SYSTEM				
H ₂ O ⁺ wash system with Auto Load Sensing				♦
Additive dispensers	Bleach, fabric softener	Bleach, fabric softener	Bleach, fabric softener	Bleach
Care Control temperature management system	♦	♦	♦	♦
Quiet Spin technology	♦	♦	♦	♦
Max spin speed (RPM)	up to 700	up to 700	up to 700	up to 800
Total number of water levels	4	4	Auto Load Sensing	Auto Load Sensing
Wash action	Xtra Roll Action™ Plus agitator	Xtra Roll Action™ Plus agitator	Xtra Roll Action™ Plus agitator	Impeller
Total number of temperatures	4	5	5	4
CYCLES AND OPTIONS				
Total number of cycles	8	12	12	12
Super Wash cycle	♦	♦	♦	♦
Normal cycle	♦	♦	♦	♦
Casual cycle	♦	♦	♦	♦
Bulky Items cycle	♦	♦	♦	♦
Delicate cycle	♦	♦	♦	♦
Quick Wash cycle	♦	♦	♦	♦
Clean Washer cycle with affresh® Washer cleaner	♦	♦	♦	♦
Soak cycle	♦	♦	♦	♦
Rinse & Spin cycle	♦	♦	♦	♦
Drain & Spin cycle	♦	♦	♦	♦
EcoBoost™ option	♦	♦	♦	♦
On/Off Extra Rinse option	♦	♦	♦	♦
On/Off Deep Water Wash option	♦	♦	♦	♦
On/Off Fabric Softener knob	♦	♦	♦	♦
ACCESSORIES				
5' Washer Inlet Hose kit (2-pack)	8212641RP	8212641RP	8212641RP	8212641RP
5' Nylon Braided Washer Fill Hose kit (2-pack)	8212487RP	8212487RP	8212487RP	8212487RP
6' Gooseneck Nylon Braided Fill Hose kit (2-pack)	8212638RP	8212638RP	8212638RP	8212638RP
10' Washer Inlet Hose kit (2-pack)	8212656RP	8212656RP	8212656RP	8212656RP
Washer drip tray	8212526	8212526	8212526	8212526
DIMENSIONS AND COLORS				
Max height (A)	43"	43"	43"	43"
Width (B)	27½"	27½"	27½"	27½"
Depth (C)	27"	27"	27"	27"
Height with door open (D)	53"	53"	53"	53"
Top height (E)	36"	36"	36"	36"
Available colors	Q	Q	W	W

Bold type indicates a step-up feature

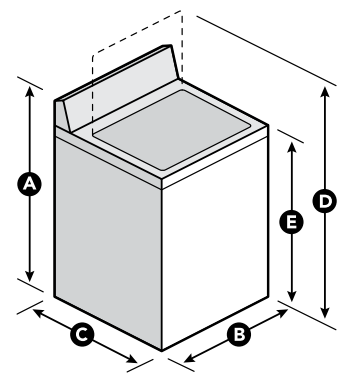

DIMENSIONS ARE SHOWN FOR PLANNING PURPOSES ONLY.
For complete information, see installation instructions packed with product.

*Based on the Consortium for Energy Efficiency qualifying product lists. Visit cee1.org for more information.
**Compared to pre-2004 traditional top load washers.

Traditional Top Load Dryers

SPECIFICATIONS AND DIMENSIONS

DRYER MODEL	WHIRLPOOL®		
	WED4800X WGD4800X	WED4850X WGD4850X	WED4900X WGD4900X
RECOMMENDED WASHERS	WTW4800X	WTW4850X WTW4800X	WTW4880A WTW4950X
Capacity (cu. ft.)	7.0	7.0	7.0
High efficiency dryer		♦	♦
On/Off end-of-cycle signal	♦	♦	♦
Interior drum light	♦	♦	♦
Door style	Reversible side-swing	Wide-opening hamper	Wide-opening hamper
DRYING SYSTEM			
AccuDry™ drying system			♦
AutoDry™ drying system	♦	♦	♦
Quiet Dry system	♦	♦	♦
Timed Dry	♦	♦	♦
Total number of temperatures	4	4	4
CYCLES AND OPTIONS			
Total number of cycles	13	13	13
Heavy Dry cycle	♦	♦	♦
Damp Dry cycle	♦	♦	♦
Tumble Press® cycle	♦	♦	♦
Jeans cycle	♦	♦	♦
Very Dry cycle	♦	♦	♦
Delicate cycle	♦	♦	♦
Less Dry cycle	♦	♦	♦
Energy Preferred cycle	♦	♦	♦
Wrinkle Shield™ option	up to 40 minutes	On/Off up to 40 minutes	On/Off up to 90 minutes
ACCESSORIES			
Dryer rack	3406839	3406839	3406839
LP Gas Conversion kit	49572A	49572A	49572A
4' Gas Dryer Hook-Up kit	20-48KITRC	20-48KITRC	20-48KITRC
4', 3-wire, 30 amp dryer cord	PT220L	PT220L	PT220L
4', 4-wire, 30 amp dryer cord	PT400L	PT400L	PT400L
6', 3-wire, 30 amp dryer cord	PT500L	PT500L	PT500L
6', 4-wire, 30 amp dryer cord	PT600L	PT600L	PT600L
DIMENSIONS AND COLORS			
Max height (A)	43"	43"	43"
Width (B)	29"	29"	29"
Depth (C)	27½"	27½"	27½"
Depth with door open (D)	40¼"	40¼"	42¼"
Top height (E)	36"	36"	36"
Available colors	Q	Q	W

Bold type indicates a step-up feature

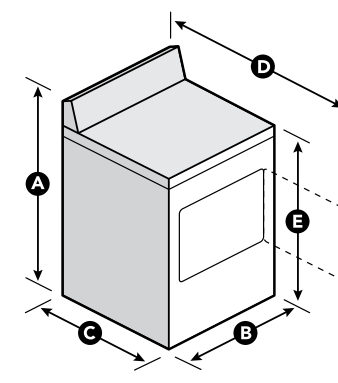

Reversible side-swing door

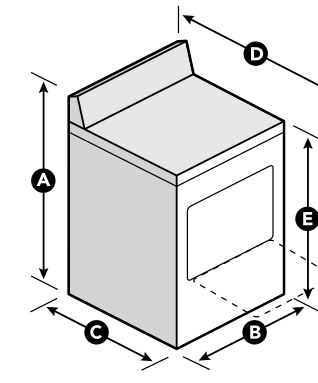

Wide-opening hamper door

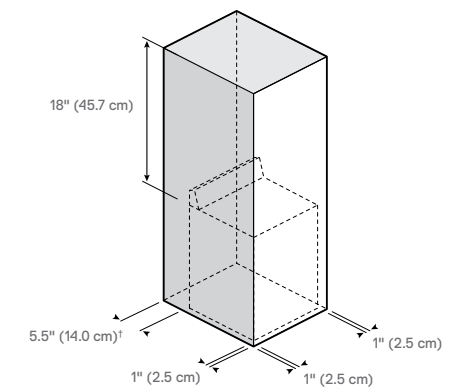

†Add 5-1/2" for proper venting of gas dryers.

Thin Twin® Laundry Centers

SPECIFICATIONS AND DIMENSIONS

MODEL	WHIRLPOOL®	
	LTE/G5243D	WE/GT3300X
Washer capacity (cu. ft.)	1.5	2.5
Thin Twin® Laundry Center	.	.
Tough Top™ II top and lid	.	.
Wash basket	Spreckle porcelain	White porcelain
WASH SYSTEM		
Additive dispensers	.	Bleach, fabric softener
Selectable water levels	3	3
Wash action	Surgilator® agitator	Two-piece Surgilator® agitator
Total number of temperatures	4	4
WASH CYCLES		
Total number of cycles	5	8
Delicate cycle	.	.
Prewash cycle	.	.
Super Wash cycle	.	.
DRYER FEATURES		
Dryer capacity (cu. ft.)	3.4	5.9
Total number of cycles	18	6
Total number of temperatures	4	3
Timed drying	.	.
Automatic Dry	.	.
Tumble Press® cycle	.	.
2-way venting	.	.
End-of cycle signal	.	.
ACCESSORIES		
Dryer rack	N/A	N/A
LP Gas Conversion kit	49573	3392235
24"/27" Thin Twin® side exhaust vent extension kit	279823	279823
4' Gas Dryer Hook-Up kit	20-48KITRC	20-48KITRC
4', 3-wire, 30 amp dryer cord	PT220L	PT220L
4', 4-wire, 30 amp dryer cord	PT400L	PT400L
6', 3-wire, 30 amp dryer cord	PT500L	PT500L
6', 4-wire, 30 amp dryer cord	PT600L	PT600L
DIMENSIONS AND COLORS		
Max height (A)	71 1/4"	71 1/4"
Width (B)	24"	27"
Depth (C)	27 1/4"	32"
Available colors	Q	Q

Bold type indicates a step-up feature

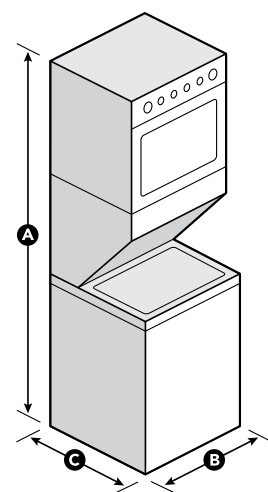

DIMENSIONS ARE SHOWN FOR PLANNING PURPOSES ONLY. For complete information, see Installation instructions packed with product.

Compact Laundry Pairs

SPECIFICATIONS AND DIMENSIONS

WASHER MODEL	WHIRLPOOL®	
	WFC7500V	WED7500V
Washer capacity (cu. ft.)	2.0	3.8
Washer configuration	Front load	Stainless steel
ENERGY STAR® qualified	.	.
Meets CEE Tier standards*	Tier 1	.
Estimated time remaining display	.	.
Cycle status bar	.	.
Lighted cycle indicators	.	.
Wash basket	Stainless steel	.
WASH SYSTEM		
Gentle wash system	.	Detergent, bleach, fabric softener
Additive dispensers	.	.
Noise reduction system	.	.
Max spin speed (RPM)	.	up to 1,200
Automatic water level control	.	.
Total number of temperatures	3	.
CYCLES AND OPTIONS		
Total number of cycles	8	.
Heavy Duty cycle	.	.
Quick Wash cycle	.	.
Clean Washer cycle	.	.
Delicate cycle	.	.
Prewash option	.	.
Delay Wash option	.	up to 12 hours
Extra Rinse option	.	.
DIMENSIONS AND COLORS		
Max height (A)	32 1/8"	33 1/4"
Width (B)	23 1/4"	23 1/4"
Depth (C)	23 1/4"	23 1/4"
Depth with door open (D)	36 1/4"	39"
Available colors	W	W
DRYER MODEL		
Capacity (cu. ft.)	3.8	5.9
Drum material	Stainless steel	.
End-of-cycle signal	.	.
Door window	.	.
Side-swing door	.	.
DRYING SYSTEM		
AutoDry™ drying system	.	.
Moisture sensor control	.	.
Long vent exhaust	.	.
Total number of temperatures	2	.
Power source	240 Volt	.
CYCLES AND OPTIONS		
Total number of cycles	11	.
Damp Dry cycle	.	.
Normal cycle	.	.
ACCESSORIES		
Dryer stack kit	Included	.
Compact Dryer Stand kit	N/A	.
4', 3-wire, 30 amp dryer cord	PT220L	.
4', 4-wire, 30 amp dryer cord	PT400L	.
6', 3-wire, 30 amp dryer cord	PT500L	.
6', 4-wire, 30 amp dryer cord	PT600L	.
DIMENSIONS AND COLORS		
Max height (A)	33 1/4"	33 1/4"
Width (B)	23 1/4"	23 1/4"
Depth (C)	23 1/4"	23 1/4"
Depth with door open (D)	39"	39"
Available colors	W	W

Bold type indicates a step-up feature

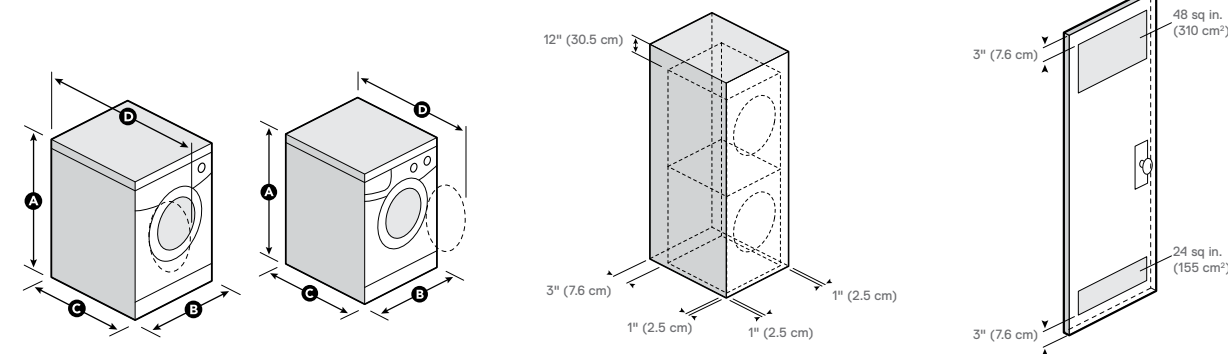

*Based on the Consortium for Energy Efficiency qualifying product lists. Visit cee1.org for more information.

Compact Laundry Pairs

SPECIFICATIONS AND DIMENSIONS

WHIRLPOOL®		
WASHER MODEL	LCE4332P	
Washer capacity (cu. ft.)	2.1	
Washer configuration	Top load	
Lighted cycle indicators	-	
Wash basket	Stainless steel	
WASH SYSTEM		
Gentle wash system	-	
Additive dispensers	Detergent, bleach, fabric softener	
Wash speeds	3	
Selectable water levels	2	
Straight vane agitator	-	
Total number of temperatures	3	
CYCLES AND OPTIONS		
Total number of cycles	4	
Heavy Duty cycle	-	
Quick Wash cycle	-	
Delicate cycle	-	
DIMENSIONS AND COLORS		
Max height (A)	35"	
Width (B)	22½"	
Depth (C)	24"	
Height with door open (D)	49¼"	
Available colors	Q	
DRYER MODEL	LER3622P	LDR3622P
Capacity (cu. ft.)	3.4	3.4
Drum material	DuraWhite™	DuraWhite™
End-of-cycle signal	-	-
Side-swing door	-	-
DRYING SYSTEM		
AccuDry™ drying system	-	
Gentle heat system	-	
Total number of temperatures	2	2
Power source	240 Volt	120 Volt
CYCLES AND OPTIONS		
Total number of cycles	3	3
ACCESSORIES		
Dryer rack	N/A	N/A
Compact Dryer Stand kit	49971	49971
4', 3-wire, 30 amp dryer cord	PT220L	PT220L
4', 4-wire, 30 amp dryer cord	PT400L	PT400L
6', 3-wire, 30 amp dryer cord	PT500L	PT500L
6', 4-wire, 30 amp dryer cord	PT600L	PT600L
DIMENSIONS AND COLORS		
Max height (A)	31"	31"
Width (B)	23⅞"	24"
Depth (C)	21⅞"	21⅞"
Depth with door open (D)	37⅞"	37⅞"
Available colors	Q	Q

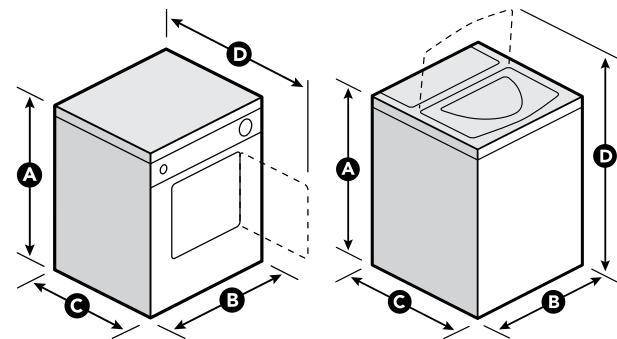

Laundry 1-2-3™ Pedestals

SPECIFICATIONS AND DIMENSIONS

MODEL	LAB0050P	XHP1000X	XHP1550V	XHP1550W	XHPC155X	XHPC155Y
Storage drawer			♦	-	-	-
Duet® pair compatible		♦	-	-	-	-
Chrome handle					♦	-
DIMENSIONS AND COLORS						
Height	12"	10"	15.5"	15.5"	15.5"	15.5"
Width	23.5"	27"	27"	27"	27"	27"
Depth	21.3"	26.8"	26.5"	26.5"	27.3"	27.3"
Available colors	Q	W	W	L R	W L R	C U

Bold type indicates a step-up feature

DIMENSIONS ARE SHOWN FOR PLANNING PURPOSES ONLY.
For complete information, see Installation Instructions packed with product.

Whirlpool brand is constantly improving and innovating our products, so the specifications in this catalog are subject to change.



Whirlpool Corporation donates a range and an ENERGY STAR® qualified refrigerator to every new Habitat for Humanity home built in North America.



With 20,000 workers throughout the country, America is home to Whirlpool Corporation as it delivers world-class appliances and exceptional service.



100 Years of Innovation Built with American Pride

Designed, engineered and assembled in the U.S.A.





BACKWARD