

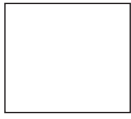

Designed to Simplify™ **Whirlpool®**

Kitchen Colors and Finishes



G/W | White

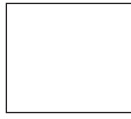

P | Pure White



B | Black



T | Biscuit



C | Pure Biscuit



D | Universal
Silver

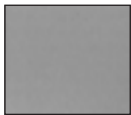

F | Monochromatic
Satina™ Steel

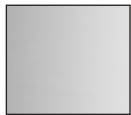

S | Stainless
Steel



Y/M | Monochromatic
Stainless Steel



R | Chrome



H | White Ice



E | Black Ice

True innovation takes the complexity out

Laundry Colors



G/W | White

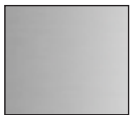

U | Diamond Steel



C | Chrome Shadow

We make it easy. Whether it's in the kitchen or the laundry room, Whirlpool® appliances will fit seamlessly into your home and your life. We balance the latest technology with effortless features that will exceed your expectations and change the way you think about appliances. Our innovations sense and adapt to your needs, so you can spend less time with your appliances and more time doing what you love.



Whirlpool® Kitchen Stylist™ Tool

Inspiration and innovation become seamless with Whirlpool brand's new online interactive kitchen design tool. Now you can try out your favorite kitchen designs and appliances like never before. Select your personal kitchen style, configuration, wall colors and cabinets to see what your virtual kitchen will look like when enhanced with Whirlpool® appliances. When you're done, you can even save and share your kitchen with friends and family.



Visit whirlpool.com/kitchen-stylist to get started now

Whirlpool brand has the Seal

Select Whirlpool® appliances have earned the Good Housekeeping Seal. For over 100 years, the Seal has helped you feel confident about your product purchases. Look for the limited warranty reflected by the Good Housekeeping Seal throughout this catalog. If these select products become defective within the first two years of purchase, Good Housekeeping will replace the product, repair it or refund the purchase price.



Visit goodhousekeeping.com/seal
for warranty details.



Laundry made easy with Whirlpool™ WashSquad

Download the newest app from Whirlpool brand and make doing laundry a fun game the whole family can enjoy. Now you can assign tasks, enjoy tips and tricks and reward family members for completing the laundry just the way you want it from the palm of your hand.



Whirlpool™ WashSquad

Search WHIRLPOOL in the App Store to download the newest laundry app from Whirlpool brand.









REFRIGERATION

- 10 French door and classic bottom-freezer refrigerators
- 20 Side-by-side refrigerators
- 28 Top-freezer refrigerators
- 42 Upright and chest freezers
- 51 Automatic icemaker
- 52 Accessories
- 54 Glossary
- 56 Specifications



WRX988SIBM

FRENCH DOOR REFRIGERATORS

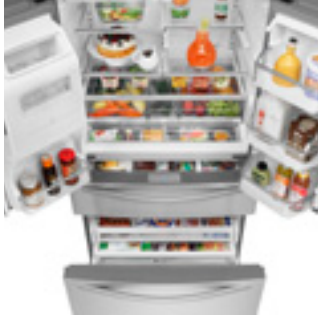

Most flexible storage*

Select models feature a FreshStor™ refrigerated drawer, EasyView™ Triple Crisper system and Tri-freezer system, so you'll always have the perfect place to store bulk food purchases, small snacks, produce and whatever else you bring home from the grocery store.



Innovative cooling

AccuFresh® dual cooling technology helps keep fruits and vegetables fresher and helps keep crystals off ice cream. It senses interior conditions and independently adapts cooling in both the refrigerator and freezer compartments so the ideal climate for fresh and frozen food is always maintained.



Creates more space with innovative spill-control technology

Keep spills under control and prevent them from leaking onto other shelves with the MicroEdge® shelves' innovative spill-control technology. They also offer 25% more usable shelf space.**



Opens up refrigerator space

The In-Door-Ice® system creates room for an extra shelf in the refrigerator compartment by storing the ice bin in the door. A removable, clear ice bin lets you fill coolers with ease.

NOTE: Not all features are available on all models.

*Among leading brand french door refrigerators with external refrigerated drawers based on combined refrigerator and freezer storage options and adjustable features. **Compared to Whirlpool® french door models without MicroEdge® shelves.

French Door Refrigerators



WRF560SFY 20 cu. ft. W | B | M

- FreshFlow™ air filter and produce preserver
- ENERGY STAR® qualified
- Meets CEE Tier 2* standards
- Adjustable gallon door bins
- Accu-Chill™ temperature management system
- SpillGuard™ glass refrigerator shelves
- Clear split-width humidity controlled crispers
- LED interior lighting



WRF560SMY 20 cu. ft. W | B | M | H | E

- PUR® 6-month ice filtration**
- Condiment Caddy**
- Factory-installed icemaker**
- FreshFlow™ air filter and produce preserver
- ENERGY STAR® qualified
- Meets CEE Tier 2* standards
- Adjustable gallon door bins
- Accu-Chill™ temperature management system
- SpillGuard™ glass refrigerator shelves
- Clear split-width humidity controlled crispers
- LED interior lighting

*Based on the Consortium for Energy Efficiency qualifying product lists. Visit cee1.org for more information.

Step-up features highlighted by yellow bar



Most Whirlpool® refrigerators are ENERGY STAR® qualified.

French Door Refrigerators



WRF560SEY 20 cu. ft. W | B | M

- PUR® 6-month ice and water filtration
- Exterior water dispenser
- FreshFlow™ air filter and produce preserver
- ENERGY STAR® qualified
- Meets CEE Tier 2* standards
- Adjustable gallon door bins
- Accu-Chill™ temperature management system
- SpillGuard™ glass refrigerator shelves
- Clear split-width humidity controlled crispers
- LED interior lighting
- Factory-installed icemaker



WRF535SMB 25 cu. ft. W | B | M **WRF532SMB 22 cu. ft. W | B | M**

- FreshFlow™ produce preserver
- ENERGY STAR® qualified
- Adjustable gallon door bins
- Accu-Chill™ temperature management system
- Glass refrigerator shelves
- Clear humidity controlled crispers
- LED interior lighting
- Factory-installed icemaker

*Based on the Consortium for Energy Efficiency qualifying product lists. Visit cee1.org for more information.

Feature descriptions can be found in the glossary on pages 54–55. Complete product specifications can be found on page 56.

French Door Refrigerators

RATED A
BEST
BUY



GX5FHTXV 25 cu. ft. Q | B | Y

Whirlpool Gold® model

Meets CEE Tier 1** standards

PUR® 6-month ice and water filtration

Interior water dispenser

ENERGY STAR® qualified

Adjustable gallon door bin

Accu-Chill™ temperature management system

SpillGuard™ glass refrigerator shelves

Clear humidity controlled crispers

Factory-installed icemaker



GI6FARXX 26 cu. ft. Q | B | F | Y

Whirlpool Gold® model

Tap Touch controls

Meets CEE Tier 2** standards

Additional adjustable gallon door bins

Exterior ice and water dispenser

ENERGY STAR® qualified

PUR® 6-month ice and water filtration

Accu-Chill™ temperature management system

SpillGuard™ glass refrigerator shelves

Clear humidity controlled crispers

Factory-installed icemaker

*According to a leading consumer magazine. **Based on the Consortium for Energy Efficiency qualifying product lists. Visit cee1.org for more information.

Step-up features
highlighted by
yellow bar



Most Whirlpool® refrigerators
are ENERGY STAR® qualified.

French Door Refrigerators



WRF736SDA 26 cu. ft. W | B | F | M

- Whirlpool Gold® model
- MicroEdge® glass refrigerator shelves
- In-Door-Ice® system
- Triple Crisper system
- Panoramic LED interior lighting
- FreshFlow™ air filter and produce preserver
- Tap Touch controls
- ENERGY STAR® qualified
- Meets CEE Tier 2** standards
- Adjustable gallon door bins
- PUR® 6-month ice and water filtration
- Accu-Chill™ temperature management system



WRF989SDA 29 cu. ft. W | B | F | M | H | E

- Whirlpool Gold® model
- AccuFresh® dual cooling technology
- Measured Fill
- MicroEdge® glass refrigerator shelves
- In-Door-Ice® system
- Triple Crisper system
- Panoramic LED interior lighting
- Tap Touch controls
- FreshFlow™ air filter and produce preserver
- ENERGY STAR® qualified
- Meets CEE Tier 2** standards
- Adjustable gallon door bins
- PUR® 6-month ice and water filtration

**Based on the Consortium for Energy Efficiency qualifying product lists. Visit cee1.org for more information.

Feature descriptions can be found in the glossary on pages 54–55. Complete product specifications can be found on pages 56–57.

French Door Refrigerators



WRX735SDB 25 cu. ft. M

Whirlpool Gold® model

External refrigerated drawer

Multiple snack compartments

Tap Touch controls

Measured Fill

ENERGY STAR® qualified

Meets CEE Tier 1* standards

Adjustable gallon door bins

PUR® 6-month ice and water filtration

Accu-Chill™ temperature management system

SpillGuard™ glass refrigerator shelves

LED interior lighting

Factory-installed icemaker

*Based on the Consortium for Energy Efficiency qualifying product lists. Visit cee1.org for more information.

Step-up features
highlighted by
yellow bar



Most Whirlpool® refrigerators
are ENERGY STAR® qualified.

French Door Refrigerators



WRX988SIB 28 cu. ft. W | B | M | H | E

Whirlpool Gold® model

FreshStor™ refrigerated drawer

EasySlide bin

MicroEdge® glass refrigerator shelves

AccuFresh® dual cooling technology

In-Door-Ice® system

EasyView™ Triple Crisper system

Tri-freezer system

FreshFlow™ air filter and produce preserver

Panoramic LED interior lighting

Tap Touch controls

Measured Fill

ENERGY STAR® qualified

Meets CEE Tier 1* standards

Adjustable gallon door bins

PUR® 6-month ice and water filtration

*Based on the Consortium for Energy Efficiency qualifying product lists. Visit cee1.org for more information.

Feature descriptions can be found in the glossary on pages 54–55. Complete product specifications can be found on page 57.

Counter Depth French Door Refrigerator



Image for feature reference only.
Model not available in Black.



GI0FSAXV 20 cu. ft. Y

- Whirlpool Gold® model
- Counter depth model: 70" height
- ENERGY STAR® qualified
- Meets CEE Tier 1* standards
- Adjustable gallon door bins
- PUR® 6-month ice and water filtration
- Accu-Chill™ temperature management system
- SpillGuard™ glass refrigerator shelves
- Clear humidity controlled crispers
- Factory-installed icemaker

*Based on the Consortium for Energy Efficiency qualifying product lists. Visit cee1.org for more information.

Step-up features
highlighted by
yellow bar



Most Whirlpool® refrigerators
are ENERGY STAR® qualified.

Bottom-Freezer Refrigerators



EB9SHKXV 19 cu. ft. Q

- ENERGY STAR® qualified
- Meets CEE Tier 1* standards
- Adjustable door bins
- Accu-Chill™ temperature management system
- Glass refrigerator shelves
- Clear humidity controlled crispers
- Reversible side-swing doors
- Factory-installed icemaker

**#1
RATED****



GB2FHDXW 22 cu. ft. Q | B | S **GB9FHDXW 19 cu. ft. Q | B | S**

- Whirlpool Gold® model
- Meets CEE Tier 3* standards
- Freezer drawer
- ENERGY STAR® qualified
- Adjustable door bins
- Accu-Chill™ temperature management system
- Glass refrigerator shelves
- Clear humidity controlled crispers
- Reversible side-swing door
- Factory-installed icemaker

*Based on the Consortium for Energy Efficiency qualifying product lists. Visit cee1.org for more information. **According to a leading consumer magazine, model GB2FHDXW only.

Feature descriptions can be found in the glossary on pages 54–55. Complete product specifications can be found on pages 58–59.



SIDE-BY-SIDE REFRIGERATORS



Industry's largest capacity side-by-side refrigerator*

Store all your favorite foods quickly and easily with leading capacity from Whirlpool brand. Select models offer gallon-size storage in the door and additional shelf and freezer space to make room for bulk food purchases and sheet cakes.



Delivers more space with innovative spill-control technology

Keep spills under control and prevent them from leaking onto other shelves with the MicroEdge® shelves' innovative spill-control technology. They also offer 25% more usable shelf space.**



Cools food quickly

Save energy and cool your food quickly with the Accu-Chill™ temperature management system. This intuitive system senses and adapts using built-in sensors to save energy and deliver efficient cooling performance, while Adaptive Defrost saves more energy† by defrosting only when necessary.



Opens up freezer space

By placing the icemaker and removable ice bin in the door, the In-Door-Ice® Plus system creates 30% more usable space in the freezer.†† The ice bin also tilts out, or can be removed with one hand, to make filling glasses or pitchers with fresh, filtered ice easy.

NOTE: Not all features are available on all models.

*Among freestanding side-by-side refrigerators. **Compared to Whirlpool® side-by-side models without MicroEdge® shelves. †As compared to Whirlpool® side-by-side refrigerators without Adaptive Defrost. ††Compared to 26 cu. ft. Whirlpool® models with conventional icemakers.

Side-by-Side Refrigerators



WRS325FDA 25 cu. ft. W | B | T | D | M
WRS322FDA 22 cu. ft. W | B | T | D | M

Accu-Chill™ temperature management system
Glass refrigerator shelves
LED interior lighting
ENERGY STAR® qualified
Meets CEE Tier 2* standards
PUR® 6-month ice and water filtration
Adjustable gallon door bins
Adaptive Defrost



WRS342FIA 22 cu. ft. W | B | M

In-Door-Ice® system
Accu-Chill™ temperature management system
Glass refrigerator shelves
LED interior lighting
ENERGY STAR® qualified
Meets CEE Tier 2* standards
PUR® 6-month ice and water filtration
Adjustable gallon door bins
Adaptive Defrost

*Based on the Consortium for Energy Efficiency qualifying product lists. Visit cee1.org for more information.

Step-up features
highlighted by
yellow bar



Most Whirlpool® refrigerators
are ENERGY STAR® qualified.

Side-by-Side Refrigerators



WSF26C2EX 26 cu. ft. W | B | F | Y

- In-Door-Ice® Plus system
- FreshFlow™ air filter
- SpillGuard™ glass refrigerator shelves
- Accu-Chill™ temperature management system
- ENERGY STAR® qualified
- Meets CEE Tier 1* standards
- PUR® 6-month ice and water filtration
- Adjustable gallon door bins
- Adaptive Defrost



WRS526SIA 26 cu. ft. H | E

- Additional SpillGuard™ glass refrigerator shelf
- In-Door-Ice® Plus system
- Accu-Chill™ temperature management system
- Glass refrigerator shelves
- FreshFlow™ air filter
- ENERGY STAR® qualified
- Meets CEE Tier 1* standards
- PUR® 6-month ice and water filtration
- Adjustable gallon door bins
- Adaptive Defrost

*Based on the Consortium for Energy Efficiency qualifying product lists. Visit cee1.org for more information.

Feature descriptions can be found in the glossary on pages 54–55. Complete product specifications can be found on page 60.

Side-by-Side Refrigerators



WRS537SIA 27 cu. ft. W | B | F | M

- LED interior lighting
- Tap Touch controls
- In-Door-Ice® Plus system
- Accu-Chill™ temperature management system
- Glass refrigerator shelves
- FreshFlow™ air filter
- ENERGY STAR® qualified
- Meets CEE Tier 3* standards
- PUR® 6-month ice and water filtration
- Adjustable gallon door bins
- Adaptive Defrost

*Based on the Consortium for Energy Efficiency qualifying product lists. Visit cee1.org for more information.

Step-up features
highlighted by
yellow bar



Most Whirlpool® refrigerators
are ENERGY STAR® qualified.

Side-by-Side Refrigerators



WRS950SIA 30 cu. ft. M | H | E

Whirlpool Gold® model

MicroEdge® glass refrigerator shelves

Panoramic LED interior lighting

In-Door-Ice® Plus system

Accu-Chill™ temperature management system

Tap Touch controls

FreshFlow™ air filter

ENERGY STAR® qualified

Meets CEE Tier 1* standards

PUR® 6-month ice and water filtration

Adjustable gallon door bins

Adaptive Defrost

*Based on the Consortium for Energy Efficiency qualifying product lists. Visit cee1.org for more information.

Feature descriptions can be found in the glossary on pages 54–55. Complete product specifications can be found on page 60.

Counter Depth Side-by-Side Refrigerators



WRS321CDB 21 cu. ft. M

Counter depth model: 69" height
Accu-Chill™ temperature management system
FreshFlow™ air filter
Glass refrigerator shelves
PUR® 6-month ice and water filtration
Adjustable gallon door bins
Adaptive Defrost



GSC25C6EY 25 cu. ft. W | B | Y

Whirlpool Gold® model
MicroEdge® glass refrigerator shelves
In-Door-Ice® Plus system
Panoramic LED interior lighting
ENERGY STAR® qualified
Meets CEE Tier 1* standards
Counter depth model: 72" height
Accu-Chill™ temperature management system
FreshFlow™ air filter
PUR® 6-month ice and water filtration
Adjustable gallon door bins
Adaptive Defrost

*Based on the Consortium for Energy Efficiency qualifying product lists. Visit cee1.org for more information.

Step-up features
highlighted by
yellow bar



Most Whirlpool® refrigerators
are ENERGY STAR® qualified.

Counter Depth Side-by-Side Refrigerators



WRS965CIA 25 cu. ft. M | H | E

Whirlpool Gold® model

Tap Touch controls

Additional adjustable gallon door bins

Counter depth model: 69" height

MicroEdge® glass refrigerator shelves

In-Door-Ice® Plus system

Accu-Chill™ temperature management system

Panoramic LED interior lighting

FreshFlow™ air filter

ENERGY STAR® qualified

Meets CEE Tier 1* standards

PUR® 6-month ice and water filtration

Adaptive Defrost

*Based on the Consortium for Energy Efficiency qualifying product lists. Visit cee1.org for more information.

Feature descriptions can be found in the glossary on pages 54–55. Complete product specifications can be found on page 61.



WRT371SZBM

TOP-FREEZER REFRIGERATORS



Flexible innovations for fresh and frozen food

Select models feature storage innovations like the largest capacity pantry drawer available,* a fold-away shelf and Tilt-N-Go door bins. Right Fit™ door bins also perfectly hold gallon-size containers. Now you can easily store groceries where you need them.



Superior cooling performance

The temperature management system senses and adapts to deliver great food preservation. Adaptive Defrost saves up to 12% more energy** by running the defrost cycle only when necessary and by monitoring how often the compressor operates and when the doors are open.



Keeps food fresh

The FreshFlow™ air filter reduces common food odors by actively circulating air through the carbon-based filter. The FreshFlow™ produce preserver also helps keep produce fresh longer† by absorbing ethylene gas that causes produce to over-ripen more quickly.



Puts filtered water in reach

Whirlpool brand offers the industry's only top-freezer refrigerator with an exterior dispenser and electronic controls. Select models offer cold, filtered water without opening the door and easy access to features.

NOTE: Not all features are available on all models.

*Among leading brand top-freezer refrigerators with pantry drawers based on drawer volume. This is only applicable to 21 cu. ft. models.

**As compared to previous Whirlpool® top-freezer models with Adaptive Defrost; based on 24-hour interval with refrigerator doors left unopened.

†Based on commonly purchased produce.

Flat Door Top-Freezer Refrigerators



W4TXNFW 14 cu. ft. Q | T

Wire refrigerator shelves
White half-width crispers
Automatic defrost system
Optional icemaker



W6TXNFW 16 cu. ft. Q | T

Wire refrigerator shelves
White full-width crisper
Automatic defrost system
Optional icemaker

Step-up features
highlighted by
yellow bar



Most Whirlpool® refrigerators
are ENERGY STAR® qualified.

Flat Door Top-Freezer Refrigerators



W5TXEWFW 15 cu. ft. Q | B

- ENERGY STAR® qualified
- Meets CEE Tier 1* standards
- Wire refrigerator shelves
- White full-width crisper
- Automatic defrost system
- Optional icemaker



W8TXNWFB 18 cu. ft. Q | B | T

- White half-width crispers
- Wire refrigerator shelves
- Automatic defrost system
- Optional icemaker

*Based on the Consortium for Energy Efficiency qualifying product lists. Visit cee1.org for more information.

Feature descriptions can be found in the glossary on pages 54–55. Complete product specifications can be found on page 62.

Flat Door Top-Freezer Refrigerators



W8TXNWMB 18 cu. ft. Q | B

- Factory-installed icemaker
- Wire refrigerator shelves
- White half-width crispers
- Automatic defrost system



W8TXNGZB 18 cu. ft. Q | B | T

- SpillMizer™ glass refrigerator and freezer shelves
- Clear half-width humidity controlled crispers
- Automatic defrost system
- Optional EZ Connect icemaker
- Sliding snack compartment

Actual image may vary

Step-up features highlighted by yellow bar



Most Whirlpool® refrigerators are ENERGY STAR® qualified.

Flat Door Top-Freezer Refrigerators



W8TXEWFY 18 cu. ft. Q | B

- ENERGY STAR® qualified
- Meets CEE Tier 1* standards
- Wire refrigerator shelves
- Clear half-width crispers
- Automatic defrost system
- Optional icemaker



W8TXEGFY 18 cu. ft. Q | B

- SpillMizer™ glass refrigerator shelves
- Clear half-width crispers
- ENERGY STAR® qualified
- Meets CEE Tier 1* standards
- Automatic defrost system
- Optional icemaker

*Based on the Consortium for Energy Efficiency qualifying product lists. Visit cee1.org for more information.

Feature descriptions can be found in the glossary on pages 54–55. Complete product specifications can be found on pages 62–63.

Flat Door Top-Freezer Refrigerators



WRT138TFY 18 cu. ft. W | B | S

- Clear split-width humidity controlled crispers
- ENERGY STAR® qualified
- Meets CEE Tier 1* standards
- SpillMizer™ glass refrigerator shelves
- Automatic defrost system
- Optional icemaker

*Based on the Consortium for Energy Efficiency qualifying product lists. Visit cee1.org for more information.

Step-up features
highlighted by
yellow bar



Most Whirlpool® refrigerators
are ENERGY STAR® qualified.

Flat Door Top-Freezer Refrigerators



Actual image may vary



WRT311FZB 21 cu. ft. M

- Adjustable door bins
- SpillMizer™ glass refrigerator and freezer shelves
- Optional EZ Connect icemaker
- ENERGY STAR® qualified
- Meets CEE Tier 1* standards
- Clear split-width humidity controlled crispers
- Automatic defrost system

*Based on the Consortium for Energy Efficiency qualifying product lists. Visit cee1.org for more information.

Feature descriptions can be found in the glossary on pages 54–55. Complete product specifications can be found on page 63.

Contoured Door Top-Freezer Refrigerators



WRT111SFA 11 cu. ft. W | B | F

- SpillMizer™ glass refrigerator shelves
- Clear full-width humidity controlled crisper
- Adjustable gallon door bin
- Automatic defrost system
- Optional icemaker



W6RXNGFW 16 cu. ft. Q | B | S

- SpillMizer™ glass refrigerator and freezer shelves
- Clear half-width humidity controlled crispers
- Sliding snack compartment
- Automatic defrost system
- Optional icemaker

Step-up features highlighted by yellow bar



Most Whirlpool® refrigerators are ENERGY STAR® qualified.

Contoured Door Top-Freezer Refrigerators



W8RXNGMB 18 cu. ft. Q | B | D | S

- Factory-installed icemaker
- SpillMizer™ glass refrigerator and freezer shelves
- Clear half-width humidity controlled crispers
- Automatic defrost system
- Sliding snack compartment



W8RXEGMW 18 cu. ft. Q | B | D | S

- ENERGY STAR® qualified
- Meets CEE Tier 1* standards
- Adjustable gallon door bins
- SpillMizer™ glass refrigerator and freezer shelves
- Clear half-width humidity controlled crispers
- Automatic defrost system
- Factory-installed icemaker
- Sliding snack compartment

*Based on the Consortium for Energy Efficiency qualifying product lists. Visit cee1.org for more information.

Feature descriptions can be found in the glossary on pages 54–55. Complete product specifications can be found on page 64.

Contoured Door Top-Freezer Refrigerators



WRT311SFY 21 cu. ft. W | B | T

- Clear split-width humidity controlled crispers
- Adjustable Right Fit™ gallon door bins
- SpillMizer™ glass refrigerator shelves
- Automatic defrost system
- Optional icemaker



WRT359SFY 19 cu. ft. W | B | F | M

- ENERGY STAR® qualified
- Meets CEE Tier 3* standards
- SpillMizer™ glass refrigerator shelves
- Clear split-width humidity controlled crispers
- Automatic defrost system
- Adjustable Right Fit™ gallon door bins

*Based on the Consortium for Energy Efficiency qualifying product lists. Visit cee1.org for more information.

Step-up features highlighted by yellow bar



Most Whirlpool® refrigerators are ENERGY STAR® qualified.

Contoured Door Top-Freezer Refrigerators



WRT371SZB 21 cu. ft. W | B | F | M

- Optional EZ Connect icemaker
- LED interior lighting
- SpillMizer™ glass refrigerator shelves
- Clear split-width humidity controlled crispers
- ENERGY STAR® qualified
- Meets CEE Tier 3* standards
- Automatic defrost system
- Adjustable Right Fit™ gallon door bins

*Based on the Consortium for Energy Efficiency qualifying product lists. Visit cee1.org for more information.

Feature descriptions can be found in the glossary on pages 54–55. Complete product specifications can be found on pages 64–65.

Contoured Door Top-Freezer Refrigerators



WRT771RWY 21 cu. ft. W | B | M

Whirlpool Gold® model

SpillMizer™ glass refrigerator and freezer shelves

Interior water dispenser

FreshFlow™ air filter and produce preserver

Adaptive Defrost

PUR® 6-month ice and water filtration

Factory-installed icemaker

Clear split-width humidity controlled crispers

ENERGY STAR® qualified

Meets CEE Tier 3* standards

Adjustable Right Fit™ gallon door bins

*Based on the Consortium for Energy Efficiency qualifying product lists. Visit cee1.org for more information.

Step-up features
highlighted by
yellow bar



Most Whirlpool® refrigerators
are ENERGY STAR® qualified.

Contoured Door Top-Freezer Refrigerators



RATED A
RECOMMENDED BUY **

WRT771REY 21 cu. ft. W | B | M

Whirlpool Gold® model

Exterior water dispenser

Fast Cool option

SpillMizer™ glass refrigerator and freezer shelves

Clear split-width humidity controlled crispers

FreshFlow™ air filter and produce preserver

ENERGY STAR® qualified

Meets CEE Tier 1* standards

Adaptive Defrost

Adjustable Right Fit™ gallon door bins

PUR® 6-month ice and water filtration

Factory-installed icemaker

*Based on the Consortium for Energy Efficiency qualifying product lists. Visit cee1.org for more information. **According to a leading consumer magazine.

Feature descriptions can be found in the glossary on pages 54–55. Complete product specifications can be found on page 65.



FREEZERS



Locks in freshness

Keep your favorite foods frozen longer* during a power outage with Whirlpool® chest freezers. Select models keep cold air in when the power goes out, so food stays frozen for up to 17 hours when there's a power outage.* That's one less thing you have to worry about.



Flexible installation

Reversible upright freezer doors can be installed to open from the right or the left, depending on kitchen style and configuration, for added flexibility.



Saves energy

The #1 rated brand for upright freezers** also delivers nearly an entire lineup of ENERGY STAR® qualified models to choose from. Now it's even easier to store extra frozen food while using less energy, which saves money and helps the environment.

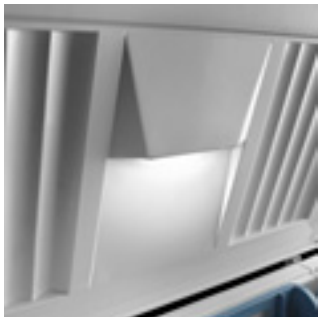

Innovative storage strength

Whirlpool® chest freezers feature a solid core lid that is durable enough to support 250 lbs without harming the chest freezer.

NOTE: Not all features are available on all models.

*Based on average performance of Whirlpool® 15 cu. ft. chest freezers using AHAM Household Refrigerator and Freezer Performance Testing (models EH151FXT and EH155FXB). **Based on rating of Whirlpool® model EV161N2T among self-defrost upright freezers by a leading consumer magazine.

Upright Freezers



EV160FXB 16 cu. ft. Q

- ENERGY STAR® qualified
- Contoured door
- Interior light
- Wire shelves
- Fast Freeze
- Lower flip-down wire gate



EV160NZT 16 cu. ft. Q

- Reversible, contoured door
- Frost-free defrost
- ENERGY STAR® qualified
- Interior light
- Wire shelves
- Fast Freeze
- Lower flip-down wire gate

Step-up features highlighted by yellow bar



Most Whirlpool® freezers are ENERGY STAR® qualified.

Upright Freezers

#1
RATED*



EV161NZT 16 cu. ft. Q

- Temperature alarm
- Lower wire basket
- ENERGY STAR® qualified
- Reversible, contoured door
- Interior light
- Wire shelves
- Frost-free defrost
- Fast Freeze



EV180NZB 18 cu. ft. Q

- ENERGY STAR® qualified
- Reversible, contoured door
- Interior light
- Wire shelves
- Frost-free defrost
- Fast Freeze
- Lower flip-down wire gate

*According to a leading consumer magazine.

Feature descriptions can be found in the glossary on pages 54–55. Complete product specifications can be found on page 66.

Upright Freezers



EV200FXB 20 cu. ft. Q

- Additional wire shelf
- ENERGY STAR® qualified
- Contoured door
- Interior light
- Fast Freeze
- Lower flip-down wire gate



EV200NQB 20 cu. ft. Q

- Reversible, contoured door
- Frost-free defrost
- ENERGY STAR® qualified
- Interior light
- Wire shelves
- Fast Freeze
- Lower flip-down wire gate

Step-up features highlighted by yellow bar



Most Whirlpool® freezers are ENERGY STAR® qualified.

Upright Freezers



EV201NZT 20 cu. ft. Q

- Temperature alarm
- Adjustable door bins
- Gallon door shelf
- Lower wire basket
- ENERGY STAR® qualified
- Reversible, contoured door
- Interior light
- Frost-free defrost
- Wire shelves
- Fast Freeze

Feature descriptions can be found in the glossary on pages 54–55. Complete product specifications can be found on page 66.

Chest Freezers



EH151FXT 15 cu. ft. Q

- ENERGY STAR® qualified
- Solid core lid
- Rounded interior corners
- 5-sided freezer coils
- Large storage baskets
- Lid lock with key
- Defrost drain with hose adapter
- Integrated door handle design



EH155FXB 15 cu. ft. Q

- Temperature alarm
- Interior light
- ENERGY STAR® qualified
- Solid core lid
- Rounded interior corners
- 5-sided freezer coils
- Large storage baskets
- Lid lock with key
- Defrost drain with hose adapter
- Integrated door handle design

Step-up features highlighted by yellow bar



Most Whirlpool® freezers are ENERGY STAR® qualified.

Chest Freezers



EH185FXT 18 cu. ft. Q

- Additional large storage basket
- ENERGY STAR® qualified
- Solid core lid
- Rounded interior corners
- 5-sided freezer coils
- Temperature alarm
- Interior light
- Lid lock with key
- Defrost drain with hose adapter
- Integrated door handle design



**RATED A
RECOMMENDED BUY***

EH225FXT 22 cu. ft. Q

- ENERGY STAR® qualified
- Solid core lid
- Rounded interior corners
- 5-sided freezer coils
- Temperature alarm
- Interior light
- Large storage baskets
- Lid lock with key
- Defrost drain with hose adapter
- Integrated door handle design

*According to a leading consumer magazine.

Feature descriptions can be found in the glossary on pages 54–55. Complete product specifications can be found on page 67.

SideKicks® Upright Freezer & Refrigerator



EV188NYW (All Freezer) 18 cu. ft. Q | S

- ENERGY STAR® qualified
- Meets CEE Tier 1* standards
- Interior light
- Mid-level wire basket
- Lower wire basket
- Frost-free defrost
- Icemaker ready
- Installation wheels

EL88TRRW (All Refrigerator) 18 cu. ft. Q | S

- ENERGY STAR® qualified
- Meets CEE Tier 1* standards
- Interior light
- Gallon door bins
- Glass refrigerator shelves
- Installation wheels
- Clear humidity controlled crispers
- Clear dairy bins

*Based on the Consortium for Energy Efficiency qualifying product lists. Visit cee1.org for more information.



Most Whirlpool® refrigerators and freezers are ENERGY STAR® qualified.

Automatic Icemaker



G15NDXZ Up to 25 lbs Q | B | S

Whirlpool Gold® model
PUR® 6-month ice filtration
Reversible, flat door
Fast Ice
Service indicator
Electronic Clean cycle
Interior light
Ice scoop

Feature descriptions can be found in the glossary on pages 54–55. Complete product specifications can be found on pages 68–69.

Accessories



FreshFlow™ Produce Preserver Starter Kit (P1FB6S1)

Help keep produce fresh longer* inside the refrigerator. This starter kit fits in any refrigerator bin.



FreshFlow™ Ice Cube & Freezer Deodorizer (4392894SRB)

Ideal for the high airflow and low moisture of the freezer, this deodorizer traps odors before they are frozen in ice cubes.



FreshFlow™ Produce Preserver (FRESH1/W10346771A)

This replaceable cartridge provides 6 months of ethylene absorption in the crisper drawer, helping keep produce fresh longer.*



FreshFlow™ Refrigerator Deodorizer (8171398SRB)

Ideal for the low airflow and high moisture levels of the refrigerator, this deodorizer absorbs powerful refrigerator odors, like onion, garlic and fish.



FreshFlow™ Air Filter (AIR1/W10311524)

This smart air filter is up to 15 times more effective than baking soda in reducing common food odors. Replace filter every 6 months for optimal performance.

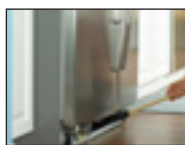

Multi-Use Cleaning Brush (4210463RW)

Recommended for cleaning refrigerators, this brush helps save energy and ensures proper performance. Size 37-1/2" (L) x 2" (W) x 2" (D).

Water Filters

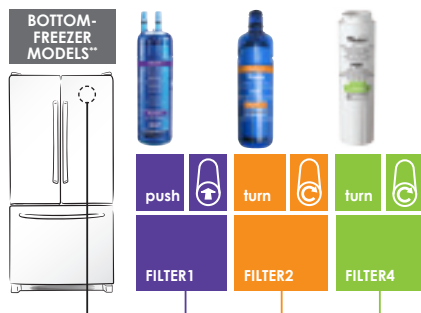

FILTER1 (W10295370A)
FILTER2 (W10413645A)
FILTER4 (UKF8001)

NOTE: FILTER1 (W10295370) is being replaced by FILTER1 (W10295370A). Both filters are still valid and useable.

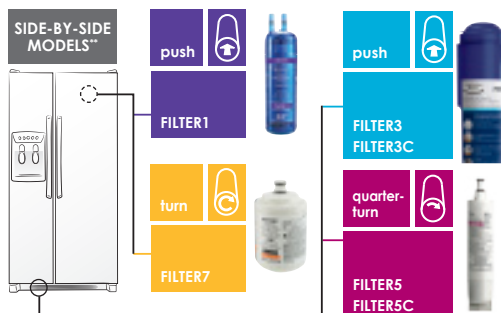

FILTER1 (W10295370A)
FILTER7 (UKF7003)
FILTER3 (4396841)
FILTER3C (4396710)
FILTER5 (4396508)
FILTER5C (4396510)

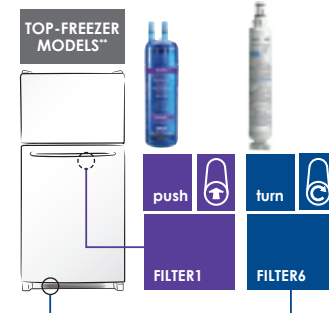

FILTER1 (W10295370A)
FILTER6 (4396701)

To acquire pricing information, order Whirlpool® refrigeration accessories and determine delivery time, visit whirlpool.com/accessories or call 1-800-462-3819.

*Based on commonly purchased produce. **Built-in and drawer refrigerators not illustrated. See your refrigerator Use and Care Guide to confirm your water filter replacement number.

Accessories

Satina™ Stainless Look Finish and Stainless Steel Side Panels

- 1 side panel (fits either side on side-by-side and french door refrigerators)
- No tools required—kit includes everything you need for installation
- Satina™ stainless look finish resists fingerprints, accepts magnets and is easy to clean

REFRIGERATOR MODEL	STAINLESS STEEL	SATINA™ STAINLESS LOOK FINISH	DIMENSIONS
23 cu. ft. Counter depth side-by-side refrigerators	4396748	N/A	24.24" W x 68.28" H
25 cu. ft. Counter depth side-by-side refrigerators	4396749	N/A	24.24" W x 71.125" H
25 cu. ft. Contoured and classic side-by-side refrigerators	4396351	8212633	27.68" W x 68.33" H
20 cu. ft. Counter depth french door refrigerators	W10194323	N/A	23.63" W x 68.31" H
25 cu. ft. Freestanding french door refrigerators	W10136753	W10137042	28.63" W x 68.33" H

SideKicks® Upright Freezer and Refrigerator Kits (See page 68 for product specifications)

- Easy to install and maintain
- Provide a built-in look without the built-in cost
- Adjustable height—install all grille extrusions or just the number of extrusions you want to create the height you desire

AVAILABLE ACCESSORY	PART NUMBER	INCLUDED EXTRUSIONS
Stainless Steel Trim Kit (18 cu. ft.)	SKT60S	Top trim extrusion (1), Grill extrusion (6), Notched grille extrusion (1), Right extrusion side trim (1), Left extrusion side trim (1), Styrofoam spacer (1), Grille bottom assembly (1), Front bracket (1) with Screws (4), Gap filler assembly and assorted screws
Stainless Steel Finishing Kit (18 cu. ft.)	SKFK60S	Styrofoam spacer (1), Grille bottom assembly (1), Front bracket (1) with Screws (4), Gap filler assembly and assorted screws

Side-by-Side Stainless Steel Top Cap

- No tools required—fits side-by-side refrigerators
- Adds 3" to refrigerator height
- Can be used with Satina™ stainless look finish or stainless steel side panels

REFRIGERATOR MODEL	PART NUMBER	DIMENSIONS
23 cu. ft. Counter depth side-by-side refrigerators	W10136975	2.62" H x 35.53" W x 27.06" D
25 cu. ft. Counter depth side-by-side refrigerators	W10136975	2.62" H x 35.53" W x 27.06" D
25 cu. ft. Freestanding side-by-side refrigerators	W10136976	2.62" H x 35.53" W x 29.88" D

(Cannot be used with contoured door refrigerators.)

Optional Icemaker Kits

REFRIGERATOR MODEL	INSTALLATION KIT	UNINSTALL KIT
24" Width refrigerators	24ECKMF	—
Side-by-side and top-freezer refrigerators	ECKMF94	4396928
SideKicks® upright freezer	ECKMF94	4396928
Bottom-freezer refrigerators	IC13B	—
30" Width french door refrigerator	IC14B	—

Glossary

Accu-Chill™ temperature management system

Built-in sensors measure the internal temperature and activate the compressor only when necessary to conserve energy while helping to keep food fresh.

AccuFresh® dual cooling technology

This innovative dual evaporator system is found on select french door refrigerators. It helps keep fruits and vegetables fresher and helps keep crystals off ice cream. It uses the ideal humidity levels in the refrigerator and freezer compartments for improved food preservation.

ADA compliant

Top-freezer refrigerators with this designation fully comply with federal guidelines for accommodating persons with disabilities.

Adaptive Defrost

Monitors when the compressor is running and defrosts only when necessary, resulting in improved food preservation and energy savings.

Adjustable door storage

Gives you the flexibility to store items anywhere in the refrigerator door by moving bins where and when you need them.

Automatic defrost system

Refrigerators with this system melt away frost so you don't have to take everything out of your freezer to melt built-up ice.

Can caddy

Holds and dispenses beverage cans to make accessing your favorite beverages quick and easy.

CEE Tier Standards

Based on the Consortium for Energy Efficiency (CEE) qualifying product lists—with the Tier 3 standard being the most efficient.

Clear convertible compartment

Helps preserve the freshness of meat and vegetables by allowing cool air from the freezer to enter the convertible compartment at the level you select.

Clear humidity controlled crispener

Help preserve the freshness of your favorite fruits and vegetables with controlled humidity levels in the clear, extra-deep crispener.

Condiment Caddy

Makes transferring condiments or other items from the refrigerator to the table or grill easy.

Counter depth configuration

Fits virtually flush with the countertop, providing up to 6 inches of additional kitchen space while retaining the features and capacity you expect from a Whirlpool® refrigerator.

EasySlide bin

Keep snacks close at hand with the industry-exclusive EasySlide bin. This snack compartment makes accessing everyday items easy with greater flexibility and sliding glass lids.

EasyView™ Triple Crisper system

Increase your refrigerator's storage flexibility and keep fruits and vegetables tasting great with the EasyView™ Triple Crisper system. Now you can easily see and access produce with full crisper drawer visibility. Plus, organize a wide variety of items with three drawer options. Automatic humidity control also helps maintain freshness.

Electronic ice and water dispenser

Dispenses filtered water on the outside of the refrigerator. A control lock feature prevents unintended operation. Select dispensers include an automatic LED night-light that adjusts brightness as the kitchen goes dark.

ENERGY STAR® qualification

Exceeds government standards by over 20% to help conserve natural resources and save money on utility bills.

EZ Connect icemaker

This optional icemaker makes adding easily accessible ice to select top-freezer refrigerators simple.

Fast Cool option

Quickly lowers the refrigerator's temperature at the push of a button. Select Fast Cool after filling your refrigerator with groceries to quickly cool fresh food.

Fast Freeze

Drops the freezer's temperature as low as it can go in the shortest amount of time. Activate Fast Freeze just before adding large amounts of unfrozen food.

Fast Ice

Drops the freezer temperature in select models for a full 24 hours to increase ice production by over 30%.*

Freezer divider

Easily customizes freezer storage and organizes frozen food using the moveable freezer divider bin.

FreshFlow™ air filter

This smart air filter is up to 15 times more effective than baking soda in reducing common food odors. Replace the filter every 6 months for optimal performance.

FreshFlow™ produce preserver

Helps keep produce fresh longer.** A cartridge absorbs ethylene gas that causes fruits and vegetables like lettuce and cantaloupe to over-ripen more quickly. Replace the filter every 6 months for optimal performance.

*Compared to normal ice production, select models only. **Based on commonly purchased produce.

Glossary

FreshStor™ refrigerated drawer

Put frequently used items in easy reach with a true refrigerated drawer. It features temperature controls that let you make adjustments based on which refrigerated items you'd like to store—from fresh produce to cold drinks. The full extension drawer and dividers also make it easy to organize and find what you need quickly.

In-Door-Ice® system

This innovative system moves the ice bin to the door, creating room for an extra shelf in the refrigerator compartment. A removable, clear ice bin lets you fill coolers with ease.

In-Door-Ice® Plus system

By placing the icemaker and removable ice bin in the door, this system creates 30% more usable space in the freezer.† The ice bin is also easily removed for portable ice any time.

LED interior lighting

LED lighting puts a spotlight on food and casts a more natural light on the contents of your refrigerator so food looks as it should.

Measured Fill

Allows you to select the exact amount of filtered water—in ounces, cups or liters—that you need. The dispenser will fill the container and automatically shut off when complete.

MicroEdge® spill-control shelf

This industry-exclusive innovation gives you 25% more usable shelf space.†† Each shelf helps create wall-to-wall storage and makes cleaning inside the refrigerator easier than before.

No-slip door bin mat

Keeps items stored in the door bins in an upright position. The mats are removable for easy cleaning.

Panoramic LED lighting

Panoramic LED lighting makes finding items in your refrigerator easier by surrounding food with light. By placing lights throughout the refrigerator, shadows are reduced from every angle.

Pizza Pocket

Easily stores frozen pizzas upright in select french door refrigerator's freezers, without the hassle of trying to fit them on flat freezer shelves.

PUR® water filtration system

Reduces contaminants from household water, giving you chilled, filtered water from your refrigerator for up to 6 months. Our new PUR® water filtration system found on select models can save you up to \$600 a year instead of buying bottled water.‡

Satina™ finish

Resists fingerprints for a smooth, glossy appearance, giving your kitchen a touch of style with everyday practicality. Accepts magnets and requires no special cleaners.

Satina™ Steel finish

Available on select models, the Satina™ Steel finish provides a look that is even closer to true stainless steel. It cleans easily without special products, resists fingerprints and is magnetic.

SideKicks® upright models

Place the refrigerator and freezer models side by side and get up to a combined 36 cu. ft. of storage for all your favorite foods. Both models feature gallon door bins and are ENERGY STAR® qualified.

SpillGuard™ glass shelf

Helps contain spills and simplifies cleanup, preventing liquids from leaking onto shelves below. Some models feature shelves that are adjustable and slide out, providing easy access to items stored in the back of the refrigerator.

SpillMizer™ glass shelf

Helps contain messy leaks and spills for easier cleanup. Shelves are both adjustable and transparent.

Tap Touch controls

This innovative interface featured on select models brings high-tech style to your kitchen. It allows direct access to refrigerator functions, and its sleek appearance enhances the appeal of any space.

Temperature-controlled pantry

A full-width temperature controlled pantry features a wide opening and holds large items like deli trays and sheet cakes.

Tilt-N-Go specialty bin

Great for condiments or a carton of eggs, this specialty bin holds items securely and can be removed from the refrigerator door and placed on the table or counter.

Tri-freezer system

Two upper sliding drawers and a spacious lower basket make organizing frozen food easy. Plus, easily customize freezer storage and organize frozen food with the moveable freezer divider bin.

Triple Crisper system

Increases storage flexibility with two larger crispers with humidity controls and a center, smaller crisper.

†Compared to 26 cu. ft. Whirlpool® models with conventional icemakers. ††Compared to Whirlpool® side-by-side or french door models without MicroEdge® shelves. ‡Based on average use of two 6-month, 200-gallon water filters versus purchasing the same amount of a leading bottled water brand.

French Door Refrigerators

SPECIFICATIONS AND DIMENSIONS

MODEL	WHIRLPOOL®				WHIRLPOOL GOLD®
	WRF560SFY	WRF560SMY	WRF560SEY	WRF535SMB WRF532SMB	GX5FHTXV
New 2013 model					
Capacity (cu. ft.)	20	20	20	25 22	25
Handle material	Metal†	Metal†	Metal†	Metal†	Metal†
Smooth door finish
Designed, engineered and assembled in the U.S.A.				♦	.
ICE & WATER FEATURES					
Dispenser			Exterior water		Interior water
PUR® 6-month ice and water filtration		Ice only	♦		♦
Water filter cartridge replacement		FILTER1 (W10295370)	FILTER1 (W10295370)		FILTER4 (UKF8001)
Factory-installed icemaker	Optional (Part No. IC14B)	♦	.	.	.
Dispenser control lock			♦		
PERFORMANCE FEATURES					
ENERGY STAR® qualified
Meets CEE Tier standards**	Tier 2	Tier 2	Tier 2		Tier 1
Accu-Chill™ temperature management system
Adaptive Defrost
Temperature controls	Electronic	Electronic	Electronic	Electronic	Electronic
FreshFlow™ produce preserver
FreshFlow™ air filter
Fast Cool option
Interior lighting	LED	LED	LED	LED	.
STORAGE FEATURES					
Refrigerator Compartment					
Clear door bins	3 adjustable gallon, 2 fixed gallon, 1 fixed	3 adjustable gallon, 2 fixed gallon	3 adjustable gallon, 2 fixed gallon	2 adjustable gallon, 4 adjustable	1 adjustable gallon, 3 adjustable
No-slip door bin mats					2
Glass shelves				4 half-width adjustable, 1 full-width fixed	
SpillGuard™ glass shelves	1 full-width slide-out adjustable, 1 full-width fixed	1 full-width slide-out adjustable, 1 full-width fixed	1 full-width slide-out adjustable, 1 full-width fixed		3 half-width adjustable slide-out, 1 half-width adjustable, 1 full-width fixed
Adjustable fold-away glass shelf	SpillGuard™	SpillGuard™	SpillGuard™		
Clear humidity controlled crispers	2 split-width	2 split-width	2 split-width	2	2
Full-width pantry	Temperature controlled	Temperature controlled	Temperature controlled	Temperature controlled	Temperature controlled
Clear snack compartment					♦
Specialty door bin		Condiment Caddy	Condiment Caddy		Can caddy
Clear dairy bin					♦
Freezer Compartment					
Upper slide-out basket	1 white plastic	1 white plastic	1 white plastic	1 wire	1 wire
Lower basket	1 white plastic	1 white plastic	1 white plastic	1 wire	1 wire
Freezer light
DIMENSIONS AND COLORS					
Height including hinges (A)	68 1/2"	68 1/2"	68 1/2"	70 1/8"	69 15/16"
Cabinet width (B)	29 1/2"	29 1/2"	29 1/2"	35 5/8" / 32 5/8"	35 5/8"
Depth including handles (C)	34 5/8"	34 5/8"	34 5/8"	35 1/2" / 34 1/2"	35 1/2"
Height excluding hinges	67 1/2"	67 1/2"	67 1/2"	68 7/8"	68 3/4"
Depth excluding handles	32 5/16"	32 5/16"	32 5/16"	33" / 32"	32 29/32"
Depth less door and base grille	28 1/2"	28 1/2"	28 1/2"	29 1/8" / 28 1/8"	29 1/8"
Depth with door open 90°	52 1/2"	52 1/2"	52 1/2"	48 5/8" / 47 5/8"	48"
Total volume (cu. ft.)	19.6	19.6	19.6	24.8 / 21.7	24.8
Refrigerator volume (cu. ft.)	13.3	13.3	13.3	17.3 / 15.4	17.3
Freezer volume (cu. ft.)	6.3	6.3	6.3	7.5 / 6.3	7.5
Total shelf area (sq. ft.)	20.1	20.1	20.1	19.0 / 16.1	28.8
Available colors	W B M	W B M H E	W B M	W B M	G B Y

Bold type indicates a step-up feature

* Monochromatic Satina™ Steel, Monochromatic Stainless Steel, White Ice and Black Ice models only.
 ** Based on the Consortium for Energy Efficiency qualifying product lists. Visit cee1.org for more information.

DIMENSIONS ARE SHOWN FOR PLANNING PURPOSES ONLY.
 For complete information, see Installation Instructions packed with product.

French Door Refrigerators

SPECIFICATIONS AND DIMENSIONS

	WHIRLPOOL GOLD®				
MODEL	G16FARXX	WRF736SDA	WRF989SSDA	WRX735SDB	WRX988SIB
New 2013 model					
Capacity (cu. ft.)	26	26	29	25	28
Handle material	Metal*	Metal*	Metal*	Metal	Metal*
Smooth door finish	•	•	•	•	•
Designed, engineered and assembled in the U.S.A.	•	•	•	•	•
ICE & WATER FEATURES					
Exterior ice and water dispenser	◆	•	•	•	•
In-Door-Ice® system	•	◆	•	•	◆
Measured Fill	•	•	◆	•	•
PUR® 6-month ice and water filtration	•	•	•	•	•
Water filter cartridge replacement	FILTER4 (UKF8001)	FILTER2 (W10413645A)	FILTER2 (W10413645A)	FILTER4 (UKF8001)	FILTER2 (W10413645A)
Factory-installed icemaker	•	•	•	•	•
Fast Ice option	•	◆	•	•	◆
Crushed ice	◆	•	•	•	•
Dispenser control lock	◆	•	•	•	•
PERFORMANCE FEATURES					
ENERGY STAR® qualified	•	•	•	•	•
Meets CEE Tier standards**	Tier 2	Tier 2	Tier 2	Tier 1	Tier 1
Cooling system/technology	Accu-Chill™	Accu-Chill™	AccuFresh® dual	Accu-Chill™	AccuFresh® dual
Adaptive Defrost	•	•	•	•	•
Temperature controls	Tap Touch	Tap Touch	Tap Touch	Tap Touch	Tap Touch
FreshFlow™ produce preserver	•	◆	•	•	◆
FreshFlow™ air filter	•	◆	•	•	◆
Fast Cool option	◆	•	•	•	◆
Interior lighting	•	Panoramic LED	Panoramic LED	LED	Panoramic LED
STORAGE FEATURES					
Refrigerator Compartment					
Clear door bins	3 adjustable gallon, 3 fixed	3 adjustable gallon, 3 fixed	3 adjustable gallon, 3 fixed	3 adjustable gallon, 3 fixed	3 adjustable gallon, 1 fixed
MicroEdge® glass shelves		3 half-width adjustable	3 half-width adjustable		3 half-width adjustable
SpillGuard™ glass shelves	3 half-width adjustable slide-out, 1 mini adjustable, 1 full-width fixed	1 full-width fixed	1 full-width fixed	1 half-width adjustable slide-out, 2 half-width adjustable, 1 mini adjustable, 1 full-width fixed	1 full-width fixed
Adjustable fold-away glass shelf		Half-width MicroEdge®	Half-width MicroEdge®		Half-width MicroEdge®
Clear humidity controlled crispers	2	Triple Crisper system	Triple Crisper system		EasyView™ Triple Crisper system
Temperature-controlled external refrigerated drawer				◆	FreshStor™
Full-width pantry	•	Temperature controlled	Temperature controlled		
Clear snack compartment				2	EasySlide bin
Freezer Compartment					
Upper slide-out baskets	1 wire	1 white plastic drawer	1 white plastic drawer	1 wire drawer	2 white plastic drawers
Lower basket	1 white plastic	1 white plastic	1 white plastic	1 white plastic	1 white plastic
Adjustable freezer divider		◆	•		◆
Pizza Pocket		◆	•		◆
Freezer light	•	•	•	•	•
DIMENSIONS AND COLORS					
Height including hinges (A)	70 1/8"	70 1/8"	70 1/8"	70 1/8"	70 1/8"
Cabinet width (B)	35 5/8"	35 1/8"	35 1/8"	35 5/8"	35 1/8"
Depth including handles (C)	35 1/4"	35 1/8"	35 1/8"	35 5/8"	35 1/8"
Height excluding hinges	68 5/8"	68 5/8"	68 5/8"	68 5/8"	68 5/8"
Depth excluding handles	32 7/8"	33 3/8"	33 3/8"	32 1/2"	33 3/8"
Depth less door and base grille	29"	28 15/16"	28 15/16"	29"	28 15/16"
Depth with door open 90°	48"	48"	48"	35 7/8"	48"
Total volume (cu. ft.)	25.5	26.1	28.5	25.0	28.1
Refrigerator volume (cu. ft.)	18.9	19.4	20.8	18.4	20.4
Freezer volume (cu. ft.)	6.6	6.8	7.7	6.6	7.7
Total shelf area (sq. ft.)	26.1	25.8	27.0	21.5	27.0
Available colors	G B F Y	W B F M	W B F M H E	M	W B M H E

Bold type indicates a step-up feature

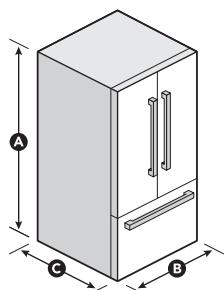

NOTE: Add 1/2" to each side for recessed installation.

ELECTRICAL REQUIREMENTS:
115V, 60Hz. (Subject to local codes.)
Listed by Underwriters' Laboratories, Inc.

*Monochromatic Satina™ Steel, Monochromatic Stainless Steel, White Ice and Black Ice models only.
**Based on the Consortium for Energy Efficiency qualifying product lists. Visit cee1.org for more information.

DIMENSIONS ARE SHOWN FOR PLANNING PURPOSES ONLY.
For complete information, see Installation Instructions packed with product.

Counter Depth French Door Refrigerator

SPECIFICATIONS AND DIMENSIONS

WHIRLPOOL GOLD®	
MODEL	GIOFSAXV
Counter depth capacity (cu. ft.)	20
Handle material	Metal
Smooth door finish	-
Designed, engineered and assembled in the U.S.A.	-
ICE & WATER FEATURES	
Exterior ice and water dispenser	-
PUR® 6-month ice and water filtration	-
Water filter cartridge replacement	FILTER4 (UKF8001)
Factory-installed icemaker	-
Dispenser control lock	-
PERFORMANCE FEATURES	
ENERGY STAR® qualified	-
Meets CEE Tier standards*	Tier 1
Accu-Chill™ temperature management system	-
Adaptive Defrost	-
Temperature controls	Electronic
Fast Cool option	-
STORAGE FEATURES	
Refrigerator Compartment	
Clear door bins	2 adjustable gallon, 2 adjustable, 2 mini fixed
No-slip door bin mats	4
SpillGuard™ glass shelves	3 half-width adjustable slide-out, 1 mini adjustable, 1 full-width fixed
Clear humidity controlled crispers	2
Full-width pantry	Temperature controlled
Freezer Compartment	
Upper slide-out baskets	2 white plastic
Lower basket	1 white plastic
Freezer light	-
DIMENSIONS AND COLORS	
Height including hinges (A)	70 1/8"
Cabinet width (B)	35 5/8"
Depth including handles (C)	30 1/4"
Height excluding hinges	68 1/8"
Depth excluding handles	27 7/8"
Depth less door and base grille	24"
Depth with door open 90°	43"
Total volume (cu. ft.)	19.8
Refrigerator volume (cu. ft.)	14.9
Freezer volume (cu. ft.)	5.0
Total shelf area (sq. ft.)	20.9
Available colors	Y

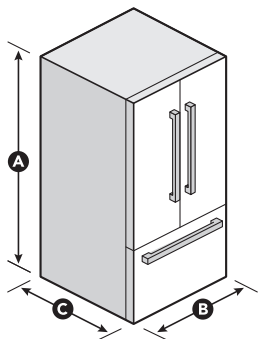

NOTE: Add 1/2" to each side for recessed installation.

ELECTRICAL REQUIREMENTS:
115V, 60Hz. (Subject to local codes.)
Listed by Underwriters' Laboratories, Inc.

*Based on the Consortium for Energy Efficiency qualifying product lists. Visit cee1.org for more information.

DIMENSIONS ARE SHOWN FOR PLANNING PURPOSES ONLY.
For complete information, see Installation Instructions packed with product.

Bottom-Freezer Refrigerators

SPECIFICATIONS AND DIMENSIONS

MODEL	WHIRLPOOL®	WHIRLPOOL GOLD®
	EB9SHKXV	GB2FHDXW GB9FHDXW
Capacity (cu. ft.)	19	22 19
Refrigerator door style	Side-swing	Side-swing
Freezer door style	Side-swing	Drawer
Handle material	Plastic	Metal**
Smooth door finish	.	.
Reversible doors	2	1
Designed, engineered and assembled in the U.S.A.	.	.
ICE & WATER FEATURES		
Factory-installed icemaker	.	.
PERFORMANCE FEATURES		
ENERGY STAR® qualified	.	.
Meets CEE Tier standards*	Tier 1	Tier 3
Accu-Chill™ temperature management system	.	.
Adaptive Defrost	.	◆
Automatic defrost system	.	.
Electronic temperature controls	.	.
STORAGE FEATURES		
Refrigerator Compartment		
Door bins	5 white half-width adjustable, 1 white full-width fixed	3 clear half-width adjustable, 1 white full-width fixed
Glass shelves	2 full-width adjustable, 1 full-width fixed	3 half-width adjustable slide-out, 1 half-width adjustable, 1 full-width fixed
Clear humidity controlled crispers	2	2
Clear dairy bin	.	◆
Clear snack compartment	.	◆
Freezer Compartment		
Door bin	1 fixed	.
Wire shelf	.	.
Upper slide-out wire basket	.	◆
Lower wire basket	.	.
Freezer light	.	.
DIMENSIONS AND COLORS		
Height including hinges (A)	66 ¹⁵ / ₁₆ "	69 ¹⁵ / ₁₆ " / 66 ¹⁵ / ₁₆ "
Cabinet width (B)	29 ⁵ / ₈ "	32 ⁵ / ₈ " / 29 ⁵ / ₈ "
Depth including handles (C)	33 ³ / ₈ "	33 ³ / ₈ "
Height excluding hinges	65 ¹ / ₂ "	65 ¹ / ₂ "
Depth excluding handles	30 ⁷ / ₈ "	30 ⁷ / ₈ "
Depth less door and base grille	28 ¹ / ₈ "	28 ¹ / ₈ "
Depth with door open 90°	59"	62" / 59"
Total volume (cu. ft.)	18.5	21.9 / 18.5
Refrigerator volume (cu. ft.)	12.9	15.6 / 12.9
Freezer volume (cu. ft.)	5.6	6.3 / 5.6
Total shelf area (sq. ft.)	20.0	23.5 / 20.0
Available colors	Q	Q B S

Bold type indicates a step-up feature

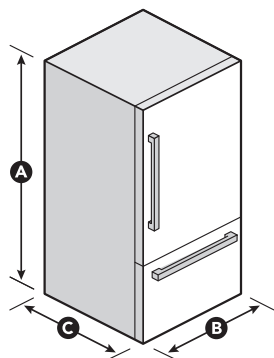

NOTE: Add 1/2" to each side for recessed installation.

ELECTRICAL REQUIREMENTS:
115V, 60Hz. (Subject to local codes.)
Listed by Underwriters' Laboratories, Inc.

*Based on the Consortium for Energy Efficiency qualifying product lists. Visit cee1.org for more information.

**Stainless Steel model only.

DIMENSIONS ARE SHOWN FOR PLANNING PURPOSES ONLY.
For complete information, see Installation Instructions packed with product.

Side-by-Side Refrigerators

SPECIFICATIONS AND DIMENSIONS

	WHIRLPOOL®						WHIRLPOOL GOLD®
MODEL	WRS325FDA WRS322FDA	WRS342FIA	WSF26C2EX	WRS526SIA	WRS537SIA	WRS950SIA	
New 2013 model	-	-	-	-	-	-	
Capacity (cu. ft.)	25 22	22	26	26	27	30	
Handle material	Metal ¹	Metal ¹	Metal ¹	Metal	Metal ¹	Metal ¹	
Smooth door finish	-	-	-	-	-	-	
Door styling	Flat	Flat	Flat	Flat	Contour	Contour	
Hidden hinges	-	-	◆	-	-	-	
WHIRLPOOL BRAND INNOVATIONS							
Accu-Chill™ temperature management system	-	-	-	-	-	-	
Adaptive Defrost	-	-	-	-	-	-	
In-Door-Ice® system	-	◆	Plus	Plus	Plus	Plus	
FreshFlow™ air filter	-	-	AIR1 (W10311524)	AIR1 (W10311524)	AIR1 (W10311524)	AIR1 (W10311524)	
ICE & WATER FEATURES							
Exterior ice and water dispenser	-	-	-	-	-	-	
PUR® 6-month ice and water filtration	-	-	-	-	-	-	
Water filter cartridge replacement	FILTER1 (W10295370A)	FILTER1 (W10295370A)	FILTER1 (W10295370A)	FILTER1 (W10295370A)	FILTER1 (W10295370A)	FILTER1 (W10295370A)	
Factory-installed icemaker	-	-	-	-	-	-	
Fast Ice option	-	-	◆	-	◆	-	
Water filter indicator light	-	-	-	-	-	-	
Control lock	-	◆	-	-	-	-	
LED dispenser night-light	-	-	◆	-	-	-	
Door alarm	-	◆	-	-	-	-	
PERFORMANCE FEATURES							
ENERGY STAR® qualified	-	-	-	-	-	-	
Meets CEE Tier standards ²	Tier 2	Tier 2	Tier 1	Tier 1	Tier 3	Tier 1	
Temperature controls	Up front interior	Exterior electronic	Exterior electronic	Exterior electronic	Tap Touch	Tap Touch	
Interior lighting	LED	LED	-	-	LED	Panoramic LED	
STORAGE FEATURES							
Refrigerator Compartment							
Door storage	3 clear adjustable gallon bins, 1 white fixed shelf	3 clear adjustable gallon bins, 1 white fixed shelf	3 clear adjustable gallon bins, 2 clear adjustable two-liter bins	2 clear adjustable gallon bins, 2 clear adjustable two-liter bins	2 clear adjustable gallon bins, 2 clear adjustable two-liter bins	2 clear adjustable gallon bins, 2 clear adjustable two-liter bins	
Interior shelves	2 adjustable glass, 1 fixed glass	2 adjustable glass, 1 fixed glass	2 adjustable slide-out SpillGuard™ glass , 1 fixed SpillGuard™ glass	3 adjustable slide-out glass , 1 fixed glass	3 adjustable slide-out glass, 1 fixed glass	3 adjustable MicroEdge® glass , 1 fixed MicroEdge® glass	
Clear humidity controlled crisper	-	-	-	-	-	-	
Clear meat compartment	-	-	-	-	-	-	
Clear convertible compartment	-	-	-	-	-	-	
Clear snack compartment	-	-	-	-	-	-	
Clear dairy bin	-	-	-	◆	-	-	
Can caddy	-	◆	-	-	-	-	
Freezer Compartment							
Fixed door storage	4 shelves	4 shelves	3 clear bins	3 clear bins	3 clear bins	3 clear bins	
Interior shelves	3 wire	3 wire	3 glass	4 glass	4 glass	4 glass	
Lower storage	White basket	White basket	Clear basket	Clear basket	Clear basket	2 clear bins	
DIMENSIONS AND COLORS							
Height including hinges (A)	69 1/8" / 66 1/4"	66 1/4"	69 1/4"	69 1/4"	69 1/4"	69 1/4"	
Cabinet width (B)	35 1/2" / 32 3/4"	32 3/4"	35 7/8"	35 7/8"	35 7/8"	35 7/8"	
Depth including handles (C)	34 5/8"	34 5/8"	34 1/8"	34 1/8"	36"	36"	
Height excluding hinges	68 7/8" / 65 7/8"	65 7/8"	68 5/8"	68 5/8"	68 5/8"	68 5/8"	
Depth excluding handles	32 3/4"	32 3/4"	32 3/8"	32 3/4"	33 1/2"	33 1/2"	
Depth less door and base grille	27 1/2"	27 1/2"	29 3/8"	29 3/8"	29 3/8"	29 3/8"	
Depth with door open 90°	49 7/8"	49 7/8"	50 13/16"	50 13/16"	50 7/8"	50 7/8"	
Total volume (cu. ft.)	25.4 / 22.0	22.0	26.4	26.4	26.5	29.7	
Refrigerator volume (cu. ft.)	15.4 / 14.6	14.6	16.4	16.4	16.6	17.5	
Freezer volume (cu. ft.)	10.0 / 7.4	7.4	9.9	9.9	9.9	12.2	
Total shelf area (sq. ft.)	23.9 / 22.0	23.0	22.8	25.1	27.4	30.4	
Available colors	W B T D M	W B M	W B F Y	H E	W B F M	M H E	

Bold type indicates a step-up feature

¹Monochromatic Satina™ Steel, Monochromatic Stainless Steel, White Ice and Black Ice models only.
²Based on the Consortium for Energy Efficiency qualifying product lists. Visit cee1.org for more information.

DIMENSIONS ARE SHOWN FOR PLANNING PURPOSES ONLY.
 For complete information, see Installation Instructions packed with product.

Counter Depth Side-by-Side Refrigerators

SPECIFICATIONS AND DIMENSIONS

MODEL	WHIRLPOOL®		WHIRLPOOL GOLD®	
	WRS321CDB	GSC25C6EY	WRS965CIA	
New 2013 model	-		-	
Capacity (cu. ft.)	21	25	25	
Handle material	Metal	Metal*	Metal	
Smooth door finish	-		-	
Door styling	Flat	Contour	Contour	
Hidden hinges	-		-	
WHIRLPOOL BRAND INNOVATIONS				
Accu-Chill™ temperature management system	-		-	
Adaptive Defrost	-		-	
In-Door-Ice® system	-		Plus	
FreshFlow™ air filter	AIR1 (W10311524)	AIR1 (W10311524)	AIR1 (W10311524)	
ICE & WATER FEATURES				
Exterior ice and water dispenser	-		-	
PUR® 6-month ice and water filtration	-		-	
Water filter cartridge replacement	FILTER1 (W10295370A)	FILTER1 (W10295370A)	FILTER1 (W10295370A)	
Factory-installed icemaker	-		-	
Water filter indicator light	-		-	
Control lock	-		-	
LED dispenser night-light	-		◆	
Door alarm	-		-	
PERFORMANCE FEATURES				
ENERGY STAR® qualified	-		◆	
Meets CEE Tier standards**	-		Tier 1	
Temperature controls	Exterior electronic	Exterior electronic	Tap Touch	
Interior lighting	-		Panoramic LED	
STORAGE FEATURES				
Refrigerator Compartment				
Door bins	3 clear adjustable gallon, 2 clear adjustable two-liter	2 clear adjustable gallon, 2 clear adjustable two-liter	4 clear adjustable gallon	
Interior shelves	3 adjustable glass, 1 fixed glass	3 adjustable MicroEdge® glass , 1 fixed MicroEdge® glass	3 adjustable MicroEdge® glass, 1 fixed MicroEdge® glass	
Clear humidity controlled crisper	-		-	
Clear convertible compartment	-		-	
Clear snack compartment	-		-	
Clear dairy bin	-		◆	
Hanging beverage rack	-		◆	
Freezer Compartment				
Fixed door storage	3 clear bins	3 clear bins	3 clear bins	
Interior shelves	4 glass	4 glass	4 glass	
Lower storage	Clear basket	2 clear bins	2 clear bins	
DIMENSIONS AND COLORS				
Height including hinges (A)	68 ¹ / ₂ "	72 ¹ / ₄ "	69 ¹ / ₄ "	
Cabinet width (B)	35 ¹ / ₂ "	35 ⁷ / ₁₆ "	35 ⁷ / ₁₆ "	
Depth including handles (C)	30"	30 ¹³ / ₁₆ "	30 ¹³ / ₁₆ "	
Height excluding hinges	68 ¹ / ₂ "	71"	68 ⁵ / ₈ "	
Depth excluding handles	27 ¹ / ₂ "	28 ⁷ / ₁₆ "	28 ³ / ₁₆ "	
Depth less door and base grille	24 ³ / ₁₆ "	24 ³ / ₁₆ "	24 ³ / ₁₆ "	
Depth with door open 90°	45 ¹ / ₄ "	45 ¹¹ / ₁₆ "	45 ¹¹ / ₁₆ "	
Total volume (cu. ft.)	21.4	24.5	24.5	
Refrigerator volume (cu. ft.)	13.6	14.3	14.5	
Freezer volume (cu. ft.)	7.9	10.2	10.0	
Total shelf area (sq. ft.)	17.8	22.5	23.3	
Available colors	M	W B Y	M H E	

Bold type indicates a step-up feature

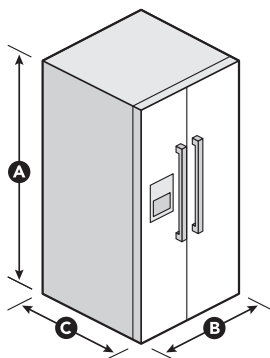

NOTE: Add 1/2" to each side for recessed installation.

ELECTRICAL REQUIREMENTS:
115V, 60Hz. (Subject to local codes.)
Listed by Underwriters' Laboratories, Inc.

*Monochromatic Satina™ Steel, Monochromatic Stainless Steel, White Ice and Black Ice models only. **Based on the Consortium for Energy Efficiency qualifying product lists. Visit cee1.org for more information.

DIMENSIONS ARE SHOWN FOR PLANNING PURPOSES ONLY.
For complete information, see Installation Instructions packed with product.

Flat Door Top-Freezer Refrigerators

SPECIFICATIONS AND DIMENSIONS

MODEL	WHIRLPOOL®					
	W4TXNWFV	W6TXNWFV	W5TXEWFV	W8TXNWFV	W8TXNWMV	W8TXNGZV
New 2013 model						
Capacity (cu. ft.)	14	16	15	18	18	18
Flat door style
Handle material	Plastic	Plastic	Plastic	Plastic	Plastic	Plastic
Handle type	Short	Short	Short	Short	Short	Short
Textured door finish
ADA compliant*	.	.	♦	.	.	.
ICE & WATER FEATURES						
Icemaker	Optional (Part no. ECKMF94)	Optional (Part no. ECKMF94)	Optional (Part no. ECKMF94)	Optional (Part no. ECKMF94)	Factory-installed	Optional EZ Connect (Part no. ECKMFEZ1)
PERFORMANCE FEATURES						
ENERGY STAR® qualified			♦			
Meets CEE Tier standards**			Tier 1			
Automatic defrost system
Up-front temperature controls
STORAGE FEATURES						
Refrigerator Compartment						
Fixed door shelves	2 full-width, 1 partial-width	2 full-width, 1 partial-width	2 full-width, 1 partial-width	2 full-width, 1 partial-width	2 full-width, 1 partial-width	2 full-width, 1 partial-width
Clear dairy bin
Interior shelves	2 full-width adjustable wire, 1 full-width fixed clear plastic	2 full-width adjustable wire, 1 full-width fixed white plastic	2 full-width adjustable wire, 1 full-width fixed white plastic	2 full-width adjustable wire, 1 full-width fixed clear plastic	2 full-width adjustable wire, 1 full-width fixed clear plastic	2 full-width adjustable SpillMizer® glass , 1 full-width fixed SpillMizer® glass
Crispers	2 white half-width	1 white full-width	1 white full-width	2 white half-width	2 white half-width	2 clear half-width humidity controlled Sliding
Clear snack compartment						
Freezer Compartment						
Door shelves	2 full-width	2 full-width	2 full-width	2 full-width	2 full-width	2 full-width
Interior shelf	1 half-width adjustable wire	1 half-width adjustable wire	1 half-width adjustable wire	1 half-width adjustable wire	1 half-width removable wire	1 full-width adjustable SpillMizer® glass
DIMENSIONS AND COLORS						
Height including hinges (A)	62 3/4"	65 3/4"	62 3/4"	67 7/8"	67 7/8"	67 7/8"
Cabinet width (B)	28"	28"	28"	28"	28"	28"
Depth including handles (C)	31 1/2"	32 7/8"	32 7/8"	32 7/8"	32 7/8"	32 7/8"
Height excluding hinges	62 1/8"	65 1/4"	62 1/8"	67 3/8"	67 3/8"	67 3/8"
Depth excluding handles	29 3/4"	30 7/8"	31 1/8"	30 7/8"	30 7/8"	30 7/8"
Depth less door and base grille	27 3/4"	27 3/4"	27 3/4"	27 3/4"	27 3/4"	27 3/4"
Depth with door open 90°	57"	57"	57"	57"	57"	57"
Total volume (cu. ft.)	14.4	15.9	14.6	17.6	17.6	17.6
Refrigerator volume (cu. ft.)	10.6	12.0	10.8	13.5	13.5	13.5
Freezer volume (cu. ft.)	3.8	3.9	3.8	4.1	4.1	4.1
Total shelf area (sq. ft.)	17.1	18.5	16.5	19.1	19.1	19.1
Available colors	Q T	Q T	Q B	Q B T	Q B	Q B T

Bold type indicates a step-up feature

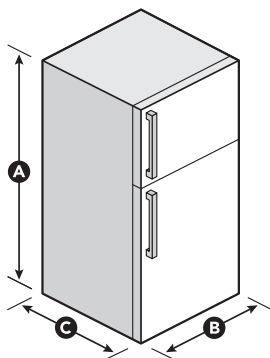

NOTE: Add 1/2" to each side for recessed installation.

ELECTRICAL REQUIREMENTS:
115V, 60Hz. (Subject to local codes.)
Listed by Underwriters' Laboratories, Inc.

* Model meets applicable ADA requirements and must be installed in compliance with the current ADA Standards.
** Based on the Consortium for Energy Efficiency qualifying product lists. Visit cee1.org for more information.

DIMENSIONS ARE SHOWN FOR PLANNING PURPOSES ONLY.
For complete information, see Installation Instructions packed with product.

Flat Door Top-Freezer Refrigerators

SPECIFICATIONS AND DIMENSIONS

	WHIRLPOOL®			
MODEL	W8TXEWFY	W8TXEGFY	WRT138TFY	WRT311FZB
New 2013 model				
Capacity (cu. ft.)	18	18	18	21
Flat door style	•	•	•	•
Handle material	Plastic	Plastic	Plastic	Metal
Handle type	Short	Short	Short	Short
Textured door finish	•	•	•	•
Door Reversal kit available			W10395148	W10395148
ADA compliant*			♦	•
ICE & WATER FEATURES				
Icemaker	Optional (Part no. ECKMF94)	Optional (Part no. ECKMF94)	Optional (Part no. ECKMF94)	Optional EZ Connect (Part no. ECKMFEZ1)
PERFORMANCE FEATURES				
ENERGY STAR® qualified	♦	•	•	•
Meets CEE Tier standards**	Tier 1	Tier 1	Tier 1	Tier 1
Automatic defrost system	•	•	•	•
Up-front temperature controls	•	•	•	•
Interior lighting			♦	•
STORAGE FEATURES				
Refrigerator Compartment				
White door bins				3 partial-width adjustable
Fixed door shelves	2 full-width, 1 partial-width	2 full-width, 1 partial-width	2 full-width, 2 partial-width	1 partial-width, 1 full-width
Interior shelves	2 full-width adjustable wire, 1 full-width fixed clear plastic	2 full-width adjustable SpillMizer™ glass , 1 full-width fixed SpillMizer™ glass	2 full-width adjustable SpillMizer™ glass, 1 full-width fixed SpillMizer™ glass	2 full-width adjustable SpillMizer™ glass, 1 full-width fixed SpillMizer™ glass
Clear crispers	2 half-width	2 half-width	2 split-width humidity controlled	2 split-width humidity controlled
Clear pantry			Partial-width	Full-width
Clear dairy bin	•	•	•	•
Freezer Compartment				
Door shelves	2 full-width	2 full-width	2 full-width	2 full-width
Interior shelf	1 full-width adjustable wire	1 full-width adjustable wire	1 full-width removable wire	1 full-width removable SpillMizer™ glass
DIMENSIONS AND COLORS				
Height including hinges (A)	67 7/8"	67 7/8"	66 1/4"	66 5/8"
Cabinet width (B)	28"	28"	29 1/2"	32"
Depth including handles (C)	32 7/8"	32 7/8"	32 3/4"	32"
Height excluding hinges	67 3/8"	67 3/8"	65 1/2"	65 1/2"
Depth excluding handles	30 7/8"	30 7/8"	30 3/4"	30 3/4"
Depth less door and base grille	27 3/4"	27 3/4"	28 1/2"	28 1/2"
Depth with door open 90°	57"	57"	59 1/4"	62 3/8"
Total volume (cu. ft.)	17.6	17.6	18.5	20.6
Refrigerator volume (cu. ft.)	13.5	13.5	13.1	14.5
Freezer volume (cu. ft.)	4.1	4.1	5.3	6.2
Total shelf area (sq. ft.)	19.1	19.1	15.7	21.0
Available colors	Q B	Q B	W B S	M

Bold type indicates a step-up feature

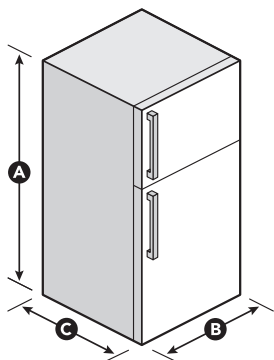

NOTE: Add 1/2" to each side for recessed installation.

ELECTRICAL REQUIREMENTS:
115V, 60Hz. (Subject to local codes.)
Listed by Underwriters' Laboratories, Inc.

* Model meets applicable ADA requirements and must be installed in compliance with the current ADA Standards.
** Based on the Consortium for Energy Efficiency qualifying product lists. Visit cee1.org for more information.

DIMENSIONS ARE SHOWN FOR PLANNING PURPOSES ONLY.
For complete information, see Installation Instructions packed with product.

Contoured Door Top-Freezer Refrigerators

SPECIFICATIONS AND DIMENSIONS

	WHIRLPOOL®				
MODEL	WRT111SFA	W6RXNGFW	W8RXNGMB	W8RXEGMW	WRT311SFY
New 2013 model					
Capacity (cu. ft.)	11	16	18	18	21
Contoured door style
Handle material					Plastic
Handle type	Integrated	Integrated	Integrated	Integrated	Contemporary
Door finish	Smooth	Smooth	Smooth	Smooth	Smooth
Hidden hinges					♦
Door Reversal kit available					W10395148
ADA compliant*					♦
ICE & WATER FEATURES					
Icemaker	Optional (Part no. 24ECKMF)	Optional (Part no. ECKMF94)	Factory-installed	Factory-installed	Optional (Part no. ECKMF94)
PERFORMANCE FEATURES					
ENERGY STAR® qualified				♦	
Meets CEE Tier standards**				Tier 1	
Temperature control system	Up-front	Up-front	Up-front	Up-front	Up-front
Automatic defrost system
Interior lighting
STORAGE FEATURES					
Refrigerator Compartment					
Clear door bins	1 full-width fixed, 1 full-width adjustable gallon, 1 full-width adjustable			2 half-width adjustable gallon, 1 half-width adjustable, 1 full-width fixed gallon	2 Right Fit™ adjustable gallon, 1 adjustable gallon
Fixed door shelves		2 full-width, 1 partial-width	2 full-width, 1 partial-width	1 full-width	1 full-width
SpillMizer™ glass interior shelves	2 full-width adjustable glass, 1 full-width fixed glass	2 full-width adjustable, 1 full-width fixed	2 full-width adjustable, 1 full-width fixed	2 full-width adjustable, 1 full-width fixed	2 full-width adjustable, 1 full-width fixed
Clear crispers	1 full-width humidity controlled	2 half-width humidity controlled	2 half-width humidity controlled	2 half-width humidity controlled	2 split-width humidity controlled
Partial-width pantry					♦
Clear snack compartment		Sliding	Sliding	Sliding	
Can caddy					♦
Clear dairy bin		♦	.	.	.
Freezer Compartment					
Door shelves	2 full-width	2 full-width	2 full-width	2 full-width	2 full-width
Interior shelf	1 half-width fixed wire	1 full-width adjustable SpillMizer™ glass	1 full-width removable SpillMizer™ glass	1 full-width removable SpillMizer™ glass	1 full-width removable wire
DIMENSIONS AND COLORS					
Overall height (A)	61 1/2"	66"	68"	68"	66 1/2"
Cabinet width (B)	24"	28"	28"	28"	32 1/2"
Depth including handles (C)	28 1/4"	30 3/8"	30 3/8"	30 3/8"	34"
Cabinet height	60 3/4"	65 3/8"	67 3/8"	67 3/8"	65 1/2"
Depth excluding handles	28 1/4"	30 3/8"	30 3/8"	30 3/8"	32 1/2"
Depth less door and base grille	21 1/2"	26 3/8"	27 1/8"	27 1/8"	28 1/2"
Depth with door open 90°	48 1/2"	55 3/8"	54 3/8"	54 3/8"	62 1/2"
Total volume (cu. ft.)	10.7	15.9	17.5	17.5	20.6
Refrigerator volume (cu. ft.)	7.8	12.0	13.5	13.5	15.0
Freezer volume (cu. ft.)	2.9	3.9	4.1	4.1	6.1
Total shelf area (sq. ft.)	11.9	18.5	18.7	18.7	21.0
Available colors	W B F	Q B S	Q B D S	Q B D S	W B T

Bold type indicates a step-up feature

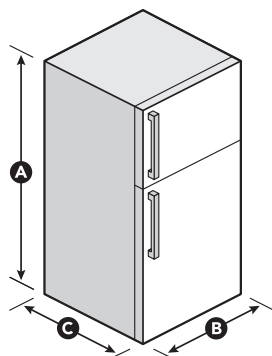

NOTE: Add 1/2" to each side for recessed installation.

ELECTRICAL REQUIREMENTS:
115V, 60Hz. (Subject to local codes.)
Listed by Underwriters' Laboratories, Inc.

* Model meets applicable ADA requirements and must be installed in compliance with the current ADA Standards.
** Based on the Consortium for Energy Efficiency qualifying product lists. Visit cee1.org for more information.

DIMENSIONS ARE SHOWN FOR PLANNING PURPOSES ONLY.
For complete information, see Installation Instructions packed with product.

Contoured Door Top-Freezer Refrigerators

SPECIFICATIONS AND DIMENSIONS

MODEL	WHIRLPOOL®		WHIRLPOOL GOLD®	
	WRT359SFY	WRT371SZB	WRT771RWY	WRT771REY
New 2013 model				
Capacity (cu. ft.)	19	21	21	21
Contoured door style	•	•	•	•
Handle material	Plastic	Plastic	Plastic	Plastic
Handle type	Contemporary	Contemporary	Embedded	Embedded
Smooth door finish	•	•	•	•
Hidden hinges	•	•	•	•
Door Reversal kit available	W10395148	W10395148		
ADA compliant*	•	•	•	•
ICE & WATER FEATURES				
Exterior water dispenser				♦
Interior water dispenser			♦	
PUR® 6-month filtration			♦	
Filter cartridge replacement			FILTER1 (W10295370)	FILTER1 (W10295370)
Icemaker	Optional (Part no. ECKMF94)	Optional EZ Connect (Part no. ECKMFEZ1)	Factory-installed with clear ice bucket	Factory-installed with clear ice bucket
Filter indicator light			•	•
PERFORMANCE FEATURES				
ENERGY STAR® qualified	♦	•	•	•
Meets CEE Tier standards**	Tier 3	Tier 3	Tier 3	Tier 1
Temperature controls	Up-front	Up-front	Up-front electronic Adaptive Defrost	Exterior electronic Adaptive Defrost
Defrost system	Automatic	Automatic		
FreshFlow™ produce preserver			FRESH1 (W10346771A)	FRESH1 (W10346771A)
FreshFlow™ air filter			AIR1 (W10311524)	AIR1 (W10311524)
Fast Cool option				♦
Interior lighting	•	LED	•	•
STORAGE FEATURES				
Refrigerator Compartment				
Door bins	2 Right Fit™ clear adjustable gallon, 1 clear adjustable gallon	2 Right Fit™ clear adjustable gallon, 1 clear adjustable gallon	2 Right Fit™ clear adjustable gallon, 1 clear adjustable gallon	2 Right Fit™ clear adjustable gallon, 1 clear adjustable gallon
Specialty door bin	Can caddy	Can caddy	Tilt-N-Go	Tilt-N-Go
Fixed door shelves	1 full-width	1 full-width	1 full-width	1 full-width
SpillMizer™ glass shelves	2 full-width adjustable, 1 full-width fixed	2 full-width adjustable, 1 full-width fixed	1 full-width adjustable, 1 full-width fixed	1 full-width adjustable, 1 full-width fixed
Adjustable fold-away glass shelf			♦	•
Clear humidity controlled crispers	2 split-width	2 split-width	2 split-width	2 split-width
Full-width pantry	♦	•	•	•
Clear dairy bin	•	•	•	•
Freezer Compartment				
Door shelves	2 full-width	2 full-width	2 full-width	2 full-width
Interior shelf	1 full-width removable wire	1 full-width removable wire	1 full-width removable SpillMizer™ glass	1 full-width removable SpillMizer™ glass
Freezer light		LED	•	•
DIMENSIONS AND COLORS				
Overall height (A)	66 3/8"	66 7/8"	66 1/4"	66 1/4"
Cabinet width (B)	29 1/2"	32 1/2"	32 1/2"	32 1/2"
Depth including handles (C)	34"	34"	34"	32 5/8"
Cabinet height	65 1/2"	65 1/2"	65 1/2"	65 1/2"
Depth excluding handles	32 5/8"	32 1/2"	34"	32 5/8"
Depth less door and base grille	28 1/2"	28 1/2"	28 1/2"	28 1/2"
Depth with door open 90°	59 1/4"	62 5/8"	62 1/4"	62 1/4"
Total volume (cu. ft.)	18.9	21.1	21.1	21.1
Refrigerator volume (cu. ft.)	13.6	15.0	15.0	15.0
Freezer volume (cu. ft.)	5.3	6.1	6.1	6.1
Total shelf area (sq. ft.)	18.0	20.2	20.2	20.2
Available colors	W B F M	W B F M	W B M	W B M

Bold type indicates a step-up feature

*Model meets applicable ADA requirements and must be installed in compliance with the current ADA Standards. **Based on the Consortium for Energy Efficiency qualifying product lists. Visit cee1.org for more information.

DIMENSIONS ARE SHOWN FOR PLANNING PURPOSES ONLY.
For complete information, see Installation Instructions packed with product.

Upright Freezers

SPECIFICATIONS AND DIMENSIONS

MODEL	WHIRLPOOL®						
	EV160FXB	EV160N2T	EV161N2T	EV180NZB	EV200FXB	EV200N2B	EV201N2T
New 2013 model
Capacity (cu. ft.)	16	16	16	18	20	20	20
Contoured door style
Door finish	Textured	Textured	Smooth	Textured	Textured	Textured	Smooth
Reversible door	.	♦	.	.	.	♦	.
Designed, engineered and assembled in the U.S.A.
PERFORMANCE FEATURES							
ENERGY STAR® qualified
Frost-free defrost	.	♦	.	.	.	♦	.
Fast Freeze
Temperature alarm	.	.	♦	.	.	.	♦
Interior light
STORAGE FEATURES							
Door storage	5 fixed shelves	5 fixed shelves	5 fixed shelves	6 fixed shelves	6 fixed shelves	6 fixed shelves	6 adjustable bins, 1 fixed gallon shelf
Mid-level storage	1 wire basket
Lower storage	1 flip-down wire gate	1 flip-down wire gate	1 wire basket	1 flip-down wire gate	1 flip-down wire gate	1 flip-down wire gate	1 wire basket
Wire shelves	3 fixed	3 removable	3 removable	3 adjustable	4 fixed	4 adjustable	4 adjustable
DIMENSIONS AND COLORS							
Height including hinges (A)	61 ⁵ / ₁₆ "	61 ¹ / ₄ "	61 ¹ / ₄ "	67 ⁵ / ₁₆ "	67 ¹ / ₄ "	67 ¹ / ₄ "	67 ¹ / ₄ "
Cabinet width (B)	32"	32"	30"	30"	33"	33"	33"
Depth including handles (C)	30 ¹ / ₄ "	31 ¹ / ₄ "	31 ¹ / ₄ "	31 ⁵ / ₁₆ "	30 ¹ / ₄ "	30 ¹ / ₄ "	31 ¹ / ₄ "
Height excluding hinges	60"	60"	60"	66"	66"	66"	66"
Depth excluding handles	30 ¹ / ₄ "	30 ¹ / ₄ "	30 ¹ / ₄ "	30 ¹ / ₄ "	30 ¹ / ₄ "	30 ¹ / ₄ "	30 ¹ / ₄ "
Depth excluding door	25 ¹ / ₂ "	25 ¹ / ₂ "	25 ¹ / ₂ "	25 ¹ / ₂ "	25 ¹ / ₂ "	25 ¹ / ₂ "	25 ¹ / ₂ "
Depth with door open 90°	56 ⁵ / ₁₆ "	56 ⁵ / ₁₆ "	56 ⁵ / ₁₆ "	56 ⁵ / ₁₆ "	59 ⁵ / ₁₆ "	59 ⁵ / ₁₆ "	59 ⁵ / ₁₆ "
Total volume (cu. ft.)	16.0	15.8	15.8	17.7	20.1	20.1	20.1
Shipping weight	170 lbs	178 lbs	176 lbs	185 lbs	211 lbs	205 lbs	211 lbs
Available colors	Q	Q	Q	Q	Q	Q	Q

Bold type indicates a step-up feature

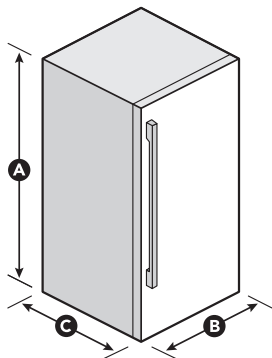

NOTE: Add 1/2" to each side for recessed installation.

ELECTRICAL REQUIREMENTS:
115V, 60Hz. (Subject to local codes.)
Listed by Underwriters' Laboratories, Inc.

DIMENSIONS ARE SHOWN FOR PLANNING PURPOSES ONLY.
For complete information, see Installation Instructions packed with product.

Chest Freezers

SPECIFICATIONS AND DIMENSIONS

MODEL	WHIRLPOOL®			
	EH151FXT	EH155FXB	EH185FXT	EH225FXT
New 2013 model				
Capacity (cu. ft.)	15	15	18	22
Flat textured lid	•	•	•	•
Integrated door handle design	•	•	•	•
1-Year limited warranty	•	•	•	•
Designed, engineered and assembled in the U.S.A.	•	•	•	•
PERFORMANCE FEATURES				
ENERGY STAR® qualified	•	•	•	•
Defrost drain with hose adapter	•	•	•	•
Mechanical controls	•	•	•	•
Adjustable thermostat	•	•	•	•
Temperature alarm		◆	•	•
Power On light		◆	•	•
Interior light		◆	•	•
5-sided freezer coils	•	•	•	•
STORAGE FEATURES				
Solid core lid	•	•	•	•
Lid lock with key	•	•	•	•
Large storage baskets	2	2	3	3
Rounded interior corners	•	•	•	•
Dishpan bottom		◆	•	•
75° Door stops			◆	•
DIMENSIONS AND COLORS				
Height (A)	34 1/4"	34 1/4"	34 1/4"	34 1/4"
Width (B)	46 1/8"	46 1/8"	54"	64 15/16"
Depth without handle (C)	28 5/8"	29 3/8"	28 5/8"	28 5/8"
Height with lid open 90°	60 1/16"	60 1/16"	60 1/16"	60 1/16"
Carton width	48 3/4"	48 3/4"	56 3/4"	67 1/2"
Carton depth	30 3/4"	30 3/4"	30 3/4"	30 3/4"
Total volume (cu. ft.)	14.8	14.8	17.5	21.7
Available colors	Q	Q	Q	Q

Bold type indicates a step-up feature

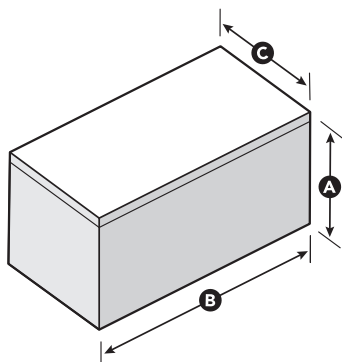

NOTE: Add 1/2" to each side for recessed installation.

ELECTRICAL REQUIREMENTS:
115V, 60Hz. (Subject to local codes.)
Listed by Underwriters' Laboratories, Inc.

DIMENSIONS ARE SHOWN FOR PLANNING PURPOSES ONLY.
For complete information, see Installation Instructions packed with product.

SideKicks® Upright Freezer & Refrigerator

SPECIFICATIONS AND DIMENSIONS

MODEL	WHIRLPOOL®	
	EV188NYW All Freezer	EL88TRRW All Refrigerator
Capacity (cu. ft.)	18	18
Flat door style	.	.
Smooth door finish	.	.
Handle material	Metal	Metal
Designed, engineered and assembled in the U.S.A.	.	.
PERFORMANCE FEATURES		
ENERGY STAR® qualified	.	.
Meets CEE Tier standards*	Tier 1	Tier 1
Frost-free defrost	.	.
Icemaker ready	ECKMF94	.
Interior light	.	.
Installation wheels	.	.
STORAGE FEATURES		
Gallon door bins	6	6
Fixed gallon door shelf	.	.
Clear dairy door bins	.	2
Mid-level storage	1 wire basket	1 meat compartment
Lower storage	1 wire basket	2 clear humidity controlled crispers
Adjustable shelves	4 glass	4 glass
DIMENSIONS AND COLORS		
Height including hinges (A)	66 5/8"	66 5/8"
Cabinet width (B)	30"	30"
Depth including handles (C)	31"	31"
Height excluding hinges	66"	66"
Depth excluding handles	28 1/2"	28 1/2"
Depth excluding door	25 1/2"	24 1/2"
Depth with door open 90°	56 5/8"	56 5/8"
Total volume (cu. ft.)	17.7	17.7
Shipping weight	186 lbs	186 lbs
Available colors	Q S	Q S

SideKicks® Upright Freezer & Refrigerator Trim Kits

SPECIFICATIONS

	PART NUMBER
Stainless Steel Trim Kit (18 cu. ft.)	SKT60S
Stainless Steel Finishing Kit (18 cu. ft.)	SKFK60S

Stainless Steel Trim Kit #SKT60S

1. Top trim extrusion (1)
2. Grill extrusion (6)
3. Notched grille extrusion (1)
4. Right extrusion side trim (1)
5. Left extrusion side trim (1)
6. Styrofoam spacer (1)
7. Grille bottom assembly (1)
8. Front bracket (1), Screws (4)
9. Gap filler assembly, Assorted screws

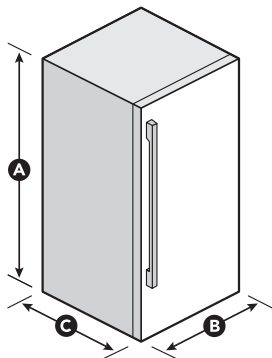

NOTE: Add 1/2" to each side for recessed installation.

ELECTRICAL REQUIREMENTS:
115V, 60Hz. (Subject to local codes.)
Listed by Underwriters' Laboratories, Inc.

Stainless Steel Finishing Kit #SKFK60S

6. Styrofoam spacer (1)
7. Grille bottom assembly (1)
8. Front bracket (1), Screws (4)
9. Gap filler assembly, Assorted screws

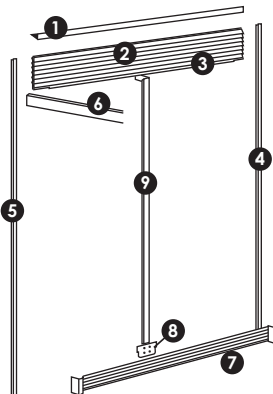

*Based on the Consortium for Energy Efficiency qualifying product lists. Visit cee1.org for more information.

DIMENSIONS ARE SHOWN FOR PLANNING PURPOSES ONLY.
For complete information, see Installation Instructions packed with product.

Automatic Icemaker

SPECIFICATIONS AND DIMENSIONS

		WHIRLPOOL GOLD®
MODEL		G115NDXZ
New 2013 model		-
Storage space		Up to 25 lbs
Ice production per day		Up to 50 lbs
Flat door style		-
Door swing		Reversible
Handle style		Lip
Designed, engineered and assembled in the U.S.A.		-
PERFORMANCE FEATURES		
PUR® 6-month ice filtration		-
Filter cartridge replacement		ICE2 (F2WC911)
Fast Ice		-
Service indicator		-
Electronic Clean cycle		-
Interior light		-
Ice scoop		-
OPTIONAL ACCESSORIES		
Self-install internal drain pump		1901
Trim kit		Q - 8171343 B - 8171345 S - 8171347
Icemaker cleaner		4396808
DIMENSIONS AND COLORS		
Height (A)		33 7/8"-34 1/8"
Width (B)		14 1/8"
Depth including handles (C)		25 1/8"
Depth excluding handles (D)		23 1/8"
Available colors		Q B S

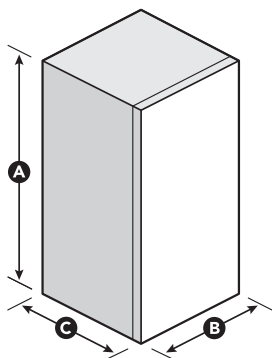

NOTE: Add 1/2" to each side for recessed installation.

ELECTRICAL REQUIREMENTS:
115V, 60Hz. (Subject to local codes.)
Listed by Underwriters' Laboratories, Inc.

Whirlpool brand is constantly improving and innovating our products, so the specifications and dimensions in this catalog are subject to change without notice.

DIMENSIONS ARE SHOWN FOR PLANNING PURPOSES ONLY.
For complete information, see Installation Instructions packed with product.





COOKING

- 72 Freestanding ranges
- 92 Wall ovens
- 100 Cooktops
- 114 Microwaves
- 122 Hoods and vents
- 132 Accessories
- 134 Glossary
- 138 Specifications



FREESTANDING RANGES



Boils 6 liters of water in 50% less time*

Select ranges feature a cooktop with AccuHeat™ induction technology. It lets you cook with less time, less energy and more precision.** This advanced technology offers easier cleaning and efficient cooking by transferring energy directly into any cookware with magnetic bases.



Bakes evenly and seals in flavors on every rack

The AccuBake® temperature management system monitors oven temperature and controls the cooking elements, delivering consistent results every time. Our most advanced models feature TimeSavor™ Plus true convection that uses a rear fan and a third heating element to seal in flavors and juices on every rack.



Innovative oven cleaning

AquaLift® self-clean technology, available on single cavity freestanding ranges, offers easy and odor-free oven cleaning in only 50 minutes.† As our most energy-efficient self-cleaning cycle available,†† it releases baked-on foods from an innovative coating throughout the oven without harsh chemicals.



More room with a view

Check on cooking progress without opening the door with the EasyView™ extra-large oven window, the industry's largest window available.‡

NOTE: Not all features are available on all models.

*Based on boiling 6 liters of water with 11" 3,700-watt induction element versus 12,500-BTU gas burner. **Compared to conventional electric radiant cooktops. †Based on average cleaning time of self-clean cycle with water and moderate soils. ††Versus traditional self clean cycle. ‡Based on interior viewable window of leading brand freestanding ranges.

Freestanding Double Oven Electric Ranges

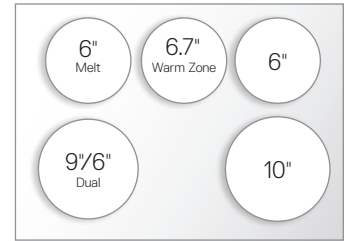

WGE555S0B 6.7 total cu. ft. W | B | S

Eco-friendly ceramic glass cooktop*

LOWER OVEN

EasyView™ extra-large oven window

BOTH OVENS

Precise Clean™ self-cleaning system

AccuBake® temperature management system

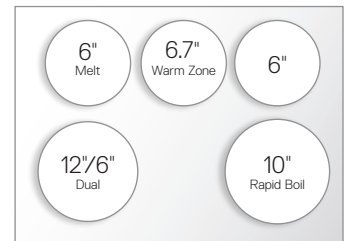

WGE755C0B 6.7 total cu. ft. S | H | E

Whirlpool Gold® model

Eco-friendly ceramic glass cooktop*

LOWER OVEN

TimeSavor™ Plus true convection

EasyView™ extra-large oven window

BOTH OVENS

SteamClean option

Hidden bake element

Precise Clean™ self-cleaning system

AccuBake® temperature management system

*Glass cooktop surface manufactured without the release of hazardous metals into the earth.

Step-up features
highlighted by
yellow bar

Freestanding Double Oven Electric Ranges

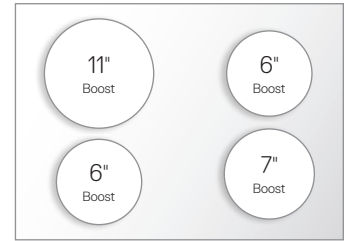

WGI925C0B 6.7 total cu. ft. Induction Range S

Whirlpool Gold® model

AccuHeat™ induction technology

Ceramic glass cooktop

LOWER OVEN

TimeSaver™ convection

EasyView™ extra-large oven window

BOTH OVENS

Precise Clean™ self-cleaning system

SteamClean option

Hidden bake element

AccuBake® temperature management system

Feature descriptions can be found in the glossary on pages 134–137. Complete product specifications can be found on page 138.

Freestanding Double Oven Gas Ranges



5,000 AccuSimmer®	9,200
15,000 Power™	9,200

WGG555S0B 6.0 total cu. ft. W | B | S

Full-width, satin-finish cast-iron grates
15,000-BTU Power™ burner
5,000-BTU AccuSimmer® burner

LOWER OVEN

EasyView™ extra-large oven window

BOTH OVENS

Precise Clean™ self-cleaning system
Hidden bake element
AccuBake® temperature management system

Step-up features
highlighted by
yellow bar

Freestanding Double Oven Gas Ranges

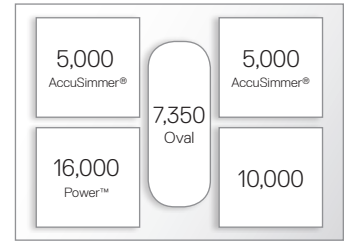

WGG755S0B 6.0 total cu. ft. S | H | E

Whirlpool Gold® model

16,000-BTU Power™ burner

Multiple 5,000-BTU AccuSimmer® burners

7,350-BTU Oval burner

Full-width, satin-finish cast-iron grates

LOWER OVEN

TimeSavor™ convection

EasyView™ extra-large oven window

BOTH OVENS

Precise Clean™ self-cleaning system

Hidden bake element

AccuBake® temperature management system

NOTE: Cooktop BTUs are listed for each model.

Feature descriptions can be found in the glossary on pages 134–137. Complete product specifications can be found on page 139.

Freestanding Electric Ranges

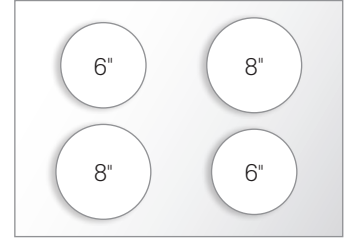

WFC130M0A 4.8 cu. ft. W | B

- Standard oven window
- Upswept porcelain SpillGuard™ cooktop
- Storage drawer

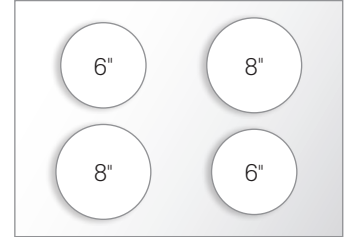

WFC340S0A 4.8 cu. ft. W | B | S

- Traditional self-cleaning system
- Large oven window
- ADA compliant*
- Upswept porcelain SpillGuard™ cooktop
- Storage drawer

*Model meets applicable ADA requirements and must be installed in compliance with the current ADA Standards.

Step-up features highlighted by yellow bar

Freestanding Electric Ranges

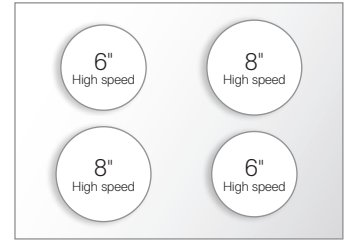

WFC310S0A 4.8 cu. ft. W | B | S

- AccuBake® temperature management system
- Traditional self-cleaning system
- Large oven window
- Upswept porcelain SpillGuard™ cooktop
- Storage drawer

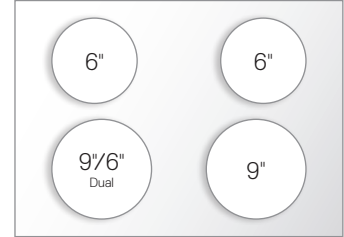

WFE320M0A 4.8 cu. ft. W | B | S

- Eco-friendly ceramic glass cooktop**
- Large oven window
- Storage drawer

** Glass cooktop surface manufactured without the release of hazardous metals into the earth.

Feature descriptions can be found in the glossary on pages 134–137. Complete product specifications can be found on page 140.

Freestanding Electric Ranges

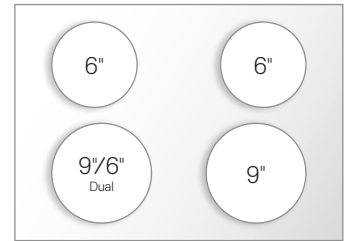

WFE510S0A 4.8 cu. ft. W | B | T | D | S

- AccuBake® temperature management system
- Traditional self-cleaning system
- Large oven window
- Eco-friendly ceramic glass cooktop*
- Storage drawer

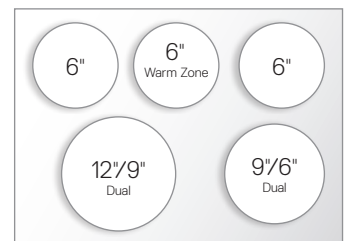

WFE540H0A 6.2 cu. ft. W | B | S | H | E

- TimeSavor™ convection
- AquaLift® self-clean technology
- EasyView™ extra-large oven window
- Hidden bake element with thermal vents
- Energy Save mode
- AccuBake® temperature management system
- Eco-friendly ceramic glass cooktop*
- Storage drawer

*Glass cooktop surface manufactured without the release of hazardous metals into the earth.

Step-up features highlighted by yellow bar

Freestanding Electric Ranges

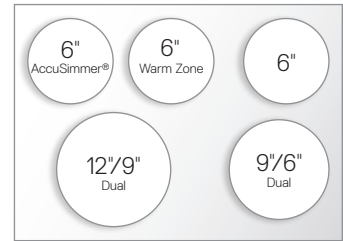

WFE710H0A 6.2 cu. ft. S | H | E

Whirlpool Gold® model

TimeSaver™ Plus true convection

Rapid Preheat

AccuSimmer® radiant element

Adjustable split rack

Convection Conversion

AccuBake® temperature management system

AquaLift® self-clean technology

EasyView™ extra-large oven window

Hidden bake element with thermal vents

Eco-friendly ceramic glass cooktop*

Energy Save mode

Storage drawer



*Glass cooktop surface manufactured without the release of hazardous metals into the earth.

Feature descriptions can be found in the glossary on pages 134–137. Complete product specifications can be found on page 141.

Freestanding Electric Ranges

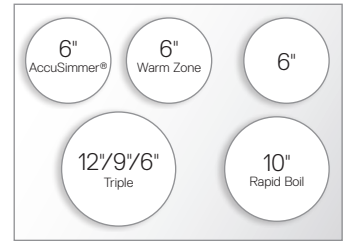

WFE720H0A 6.2 cu. ft. S

Whirlpool Gold® model

Rapid Boil element

Adjustable warming drawer with handle

AccuBake® temperature management system

TimeSaver™ Plus true convection

AquaLift® self-clean technology

Rapid Preheat

AccuSimmer® radiant element

EasyView™ extra-large oven window

Adjustable split rack

Convection Conversion

Hidden bake element with thermal vents

Eco-friendly ceramic glass cooktop*

Energy Save mode



*Glass cooktop surface manufactured without the release of hazardous metals into the earth.

Step-up features
highlighted by
yellow bar

Freestanding Electric Ranges



WF1910H0A 6.2 cu. ft. Induction Range S

Whirlpool Gold® model

AccuHeat™ induction technology

AccuBake® temperature management system

TimeSavor™ Plus true convection

AquaLift® self-clean technology

Rapid Preheat

EasyView™ extra-large oven window

Adjustable split rack

Convection Conversion

Hidden bake element with thermal vents

Adjustable warming drawer with handle

Ceramic glass cooktop

Energy Save mode

Feature descriptions can be found in the glossary on pages 134–137. Complete product specifications can be found on page 141.

Freestanding Gas Ranges



9,500	9,500
11,500	9,500

WFG114SW 4.4 cu. ft. Q | B

- Cast-iron grates
- Standard oven window
- Broiler drawer



7,000	7,500 Oval	7,000
8,000		7,000

WFG231LV 4.4 cu. ft. Q | B | S

- Large oven window
- Center griddle included
- 7,500-BTU Oval burner
- Cast-iron grates
- Broiler drawer

Step-up features highlighted by yellow bar

Freestanding Gas Ranges



9,500	5,000 AccuSimmer®
13,500 Power™	9,500

WFG510S0A 5.0 cu. ft. W | B | T | D | S

- AccuBake® temperature management system
- Traditional self-cleaning system
- 13,500-BTU Power™ burner
- 5,000-BTU AccuSimmer® burner
- Satin-finish, cast-iron grates
- Storage drawer
- Large oven window



9,500	5,000 AccuSimmer®
15,000 Power™	15,000 Power™

WFG520S0A 5.0 cu. ft. W | B | S

- Multiple 15,000-BTU Power™ burners
- Full-width, satin-finish cast-iron grates
- AccuBake® temperature management system
- 5,000-BTU AccuSimmer® burner
- Traditional self-cleaning system
- Large oven window
- Storage drawer

NOTE: Cooktop BTUs are listed for each model.

Feature descriptions can be found in the glossary on pages 134–137. Complete product specifications can be found on page 142.

Freestanding Gas Ranges



WFG540H0A 5.8 cu. ft. W | B | S | H | E

- TimeSavor™ convection
- AquaLift® self-clean technology
- EasyView™ extra-large oven window
- 17,000-BTU and 15,000-BTU Power™ burners
- Energy Save mode
- Middle burner
- AccuBake® temperature management system
- 5,000-BTU AccuSimmer® burner
- Full-width, satin-finish cast-iron grates
- Storage drawer

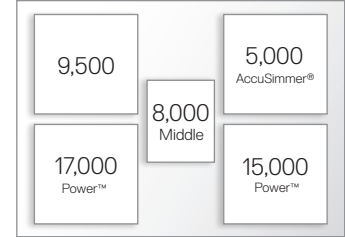

WFG710H0A 5.8 cu. ft. S | H | E

- Whirlpool Gold® model
- Rapid Preheat
- Adjustable split rack
- Convection Conversion
- Side-integrated griddle included
- AccuBake® temperature management system
- TimeSavor™ convection
- AquaLift® self-clean technology
- EasyView™ extra-large oven window
- 17,000-BTU and 15,000-BTU Power™ burners
- 5,000-BTU AccuSimmer® burner
- Full-width, satin-finish cast-iron grates
- Energy Save mode
- Middle burner
- Storage drawer



Step-up features highlighted by yellow bar

Freestanding Gas Ranges



WFG720H0A 5.8 cu. ft. S

Whirlpool Gold® model

TimeSaver™ Plus true convection

Adjustable warming drawer with handle

AccuBake® temperature management system

AquaLift® self-clean technology

Rapid Preheat

EasyView™ extra-large oven window

17,000-BTU and 15,000-BTU Power™ burners

5,000-BTU AccuSimmer® burner

Adjustable split rack

Convection Conversion

Side-integrated griddle included

Full-width, satin-finish cast-iron grates

Energy Save mode

Middle burner



NOTE: Cooktop BTUs are listed for each model.

Feature descriptions can be found in the glossary on pages 134–137. Complete product specifications can be found on page 142.

Slide-In Electric Ranges

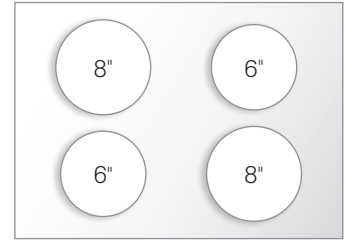

RY160LXT 4.3 cu. ft. Q | B | S

Precise Clean™ self-cleaning system
Extra-large oven window

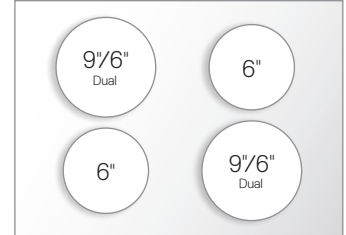

GY397LXU 4.5 cu. ft. Q | B | S

Whirlpool Gold® model
AccuBake® temperature management system
Eco-friendly ceramic glass cooktop*
Precise Clean™ self-cleaning system
Extra-large oven window

*Glass cooktop surface manufactured without the release of hazardous metals into the earth.

Step-up features
highlighted by
yellow bar

Slide-In Electric Ranges

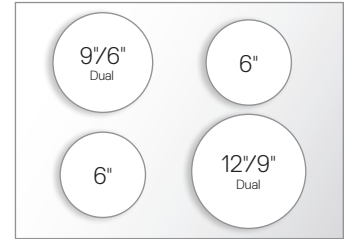

GY399LXU 4.5 cu. ft. Q | B | S

Whirlpool Gold® model

TimeSaver™ Plus true convection

Hidden bake element

AccuBake® temperature management system

Precise Clean™ self-cleaning system

Extra-large oven window

Eco-friendly ceramic glass cooktop*

*Glass cooktop surface manufactured without the release of hazardous metals into the earth.

Feature descriptions can be found in the glossary on pages 134–137. Complete product specifications can be found on page 143.

Slide-In Gas Ranges



5,000	9,200
9,200	14,000 Power™

GW397LXU 4.5 cu. ft. Q | B | S

- Whirlpool Gold® model
- AccuBake® temperature management system
- Precise Clean™ self-cleaning system
- Extra-large oven window
- 14,000-BTU Power™ burner
- Continuous satin-finish, cast-iron grates
- Hidden bake element
- ADA compliant*



5,000	9,200
12,500 Power™	16,000 Power™

GW399LXU 4.5 cu. ft. Q | B | S

- Whirlpool Gold® model
- TimeSavor™ Plus true convection**
- 16,000-BTU and 12,500-BTU Power™ burners**
- AccuBake® temperature management system
- Precise Clean™ self-cleaning system
- Extra-large oven window
- Continuous satin-finish, cast-iron grates
- Hidden bake element

NOTE: Cooktop BTUs are listed for each model.

*Model meets applicable ADA requirements and must be installed in compliance with the current ADA Standards.

Step-up features
highlighted by
yellow bar

Drop-In Electric Ranges

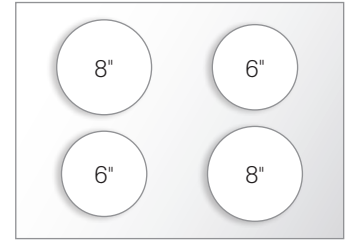

WDE150LV 4.5 cu. ft. Q | B | S

AccuBake® temperature management system
 Self-cleaning system with Delay Clean
 Large oven window

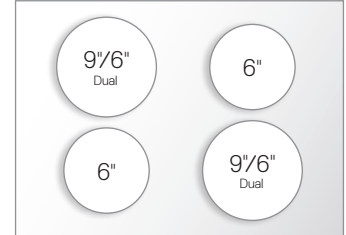

WDE350LV 4.5 cu. ft. Q | B | S

Eco-friendly ceramic glass cooktop**
 AccuBake® temperature management system
 Self-cleaning system with Delay Clean
 Large oven window

**Glass cooktop surface manufactured without the release of hazardous metals into the earth.

Feature descriptions can be found in the glossary on pages 134–137. Complete product specifications can be found on pages 143–144.



WALL OVENS



Seals in flavors and bakes evenly

TimeSavor™ Ultra true convection uses a rear fan, a third 2,500-watt heating element and an innovative X-shaped baffle to distribute heated air more efficiently in four directions. The AccuBake® system also surrounds food with even temperatures to achieve consistent results every time.



Cleans easily

The SteamClean option makes cleanup easy. It spot cleans everyday light spills using only heat and 1-1/4 cups of water—no harsh chemicals or cleaners needed.



Easy-to-install sophisticated design

Replacing your wall oven just got easier. With the FIT system, your wall oven can fit seamlessly into your current cabinet cutout.* This sleek finish is complemented by modern handles and color options that add a sophisticated look to any kitchen.



Largest capacity wall oven available**

Cook multiple dishes for a large family meal or prepare treats for a bake sale with double oven capacities of up to 10.0 total cu. ft. Now there's plenty of room to handle even your largest cooking tasks.

NOTE: Not all features are available on all models.

*Available on 27" and 30" double and single wall ovens. See product specifications for minimum and maximum installation dimensions.

**Among leading brand 27" or 30" wall ovens.

Single Wall Ovens



RBS245PR 24" 3.1 cu. ft. Q | B | S

AccuBake® temperature management system
Large oven window

RATED A
**BEST
BUY**



WOS51EC0A 30" 5.0 cu. ft. W | B | T | S

WOS51EC7A 27" 4.3 cu. ft. W | B | S

SteamClean option
FIT system
EasyView™ extra-large oven window
Hidden bake element
AccuBake® temperature management system

*According to a leading consumer magazine, model WOS51EC0A only. **FIT System Limited Guarantee: If our 27" or 30" standard single or double wall ovens featuring the FIT System do not fit your existing cabinet cut-out of a compatible width and configuration, contact us within 30 days of the purchase date and receive up to \$250 toward the cost of professional cabinet modification. Valid for qualified replacement models purchased between 5/1/12–12/31/14; excludes new cabinet installations. Visit whirlpool.com/fitsystemlimitedguarantee for complete details.

Step-up features
highlighted by
yellow bar



All 27" and 30" single oven models are backed by the FIT System Limited Guarantee to fit your existing cabinet cutout.**

Single Wall Ovens

#1
RATED†



WOS92EC0A 30" 5.0 cu. ft. B | S | H | E
WOS92EC7A 27" 4.3 cu. ft. W | B | S

Whirlpool Gold® model

TimeSaver™ Ultra true convection

Rapid Preheat

Convection Conversion

AccuBake® temperature management system

SteamClean option

FIT system

EasyView™ extra-large oven window

Hidden bake element

†According to a leading consumer magazine, model WOS92EC0A only.

Feature descriptions can be found in the glossary on pages 134–137. Complete product specifications can be found on page 145.

Double Wall Ovens



RBD245PR 24" 6.2 total cu. ft. Q | B | S

AccuBake® temperature management system
Large oven window

RATED A
RECOMMENDED BUY*



WOD51EC0A 30" 10.0 total cu. ft. W | B | S

WOD51EC7A 27" 8.6 total cu. ft. W | B | S

SteamClean option
FIT system
EasyView™ extra-large oven window
Hidden bake element
AccuBake® temperature management system

*According to a leading consumer magazine, model WOD51EC0A. **FIT System Limited Guarantee: If our 27" or 30" standard single or double wall ovens featuring the FIT System do not fit your existing cabinet cut-out of a compatible width and configuration, contact us within 30 days of the purchase date and receive up to \$250 toward the cost of professional cabinet modification. Valid for qualified replacement models purchased between 5/1/12-12/31/14; excludes new cabinet installations. Visit whirlpool.com/fitsystemlimitedguarantee for complete details.

Step-up features
highlighted by
yellow bar



All 27" and 30" double oven models are backed by the FIT System Limited Guarantee to fit your existing cabinet cutout.**

Double Wall Ovens

#1
RATED†



WOD93EC0A 30" 10.0 total cu. ft. B | S | H | E
WOD93EC7A 27" 8.6 total cu. ft. W | B | S

Whirlpool Gold® model

TimeSaver™ Ultra true convection

Rapid Preheat

Convection Conversion

AccuBake® temperature management system

SteamClean option

FIT system

EasyView™ extra-large oven window

Hidden bake element

†According to a leading consumer magazine, model WOD93EC0A only.

Feature descriptions can be found in the glossary on pages 134–137. Complete product specifications can be found on page 146.

Combination Microwave Wall Ovens



WOC54EC0A 30" 6.4 total cu. ft. W | B | S
WOC54EC7A 27" 5.7 total cu. ft. W | B | S

AccuBake® temperature management system

SteamClean option

EasyView™ extra-large oven window

Hidden bake element

Sensor microwave with drop-down door

Step-up features
highlighted by
yellow bar

Combination Microwave Wall Ovens



WOC95EC0A 30" 6.4 total cu. ft. B | S | H | E

Whirlpool Gold® model

TimeSaver™ Ultra true convection

Rapid Preheat

Convection Conversion

AccuBake® temperature management system

SteamClean option

EasyView™ extra-large oven window

Hidden bake element

Sensor microwave with drop-down door

Feature descriptions can be found in the glossary on pages 134–137. Complete product specifications can be found on page 147.



G7CG3665XS

COOKTOPS



Offers flexible cooking options

Select gas cooktops feature a 17,000-BTU Flex Power™ burner that achieves high heat to quickly boil water. You can also simmer, sear and melt quickly and easily with the 30" electric cooktop with five elements and features like triple radiant elements and bridge elements.



Precise temperature control

Master your most delicate dishes with the precise temperature control from AccuSimmer® elements and burners. You can also easily melt butter, cook custards and simmer sauces. The AccuSimmer® Plus element offers accurate control, reaching lower temperatures.



Delivers innovative AccuHeat™ induction technology

Select cooktops feature AccuHeat™ induction technology and transfer energy directly into cookware with magnetic bases. Now our most energy-efficient cooktops ever offer faster, more energy-efficient cooking. And since the cooking surface cools down fast, spills won't bake onto it.



Boils water in up to half the time*

The Boost function dramatically increases power for greater cooking flexibility and immediate responsiveness. Faster boiling helps you prepare pasta, soup and water for tea more quickly. You'll even sauté and fry faster, too.

NOTE: Not all features are available on all models.

*Compared to boiling 3.6 liters of water with a traditional 9" 2,500-watt radiant element or a 12,500-BTU gas burner.

Electric Cooktops

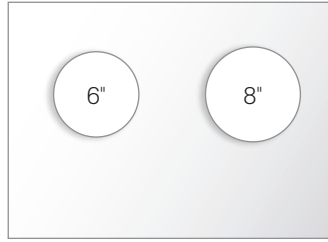

RCS2012R 21" S

- High-speed coil elements
- Infinite heat controls
- Chrome drip bowls

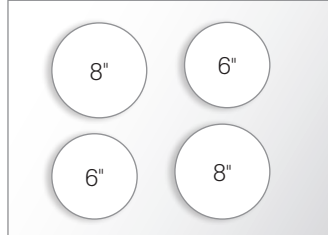

WCC31430A 30" W | B | R

- Dishwasher-safe control knobs
- No Drip chrome drip bowls
- High-speed coil elements
- Infinite heat controls

Step-up features
highlighted by
yellow bar

Electric Cooktops

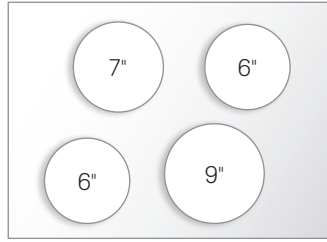

W5CE3024X 30" W | B | S

Eco-friendly ceramic glass cooktop*

Ceramic glass radiant elements

Dishwasher-safe control knobs

Infinite heat controls

RATED A
BEST
BUY**

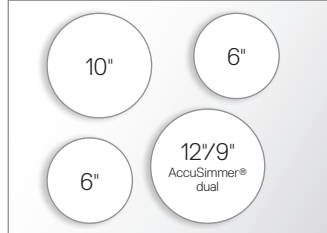
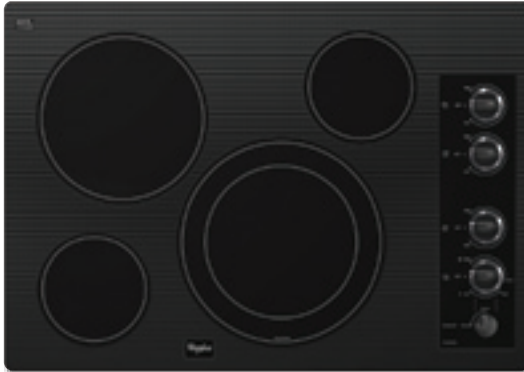

G7CE3034X 30" P | B | C | S

Whirlpool Gold® model

AccuSimmer® dual radiant element

Dishwasher-safe, stainless steel finish control knobs†

Ceramic glass radiant elements

Eco-friendly ceramic glass cooktop*

Infinite heat controls

*Glass cooktop surface manufactured without the release of hazardous metals into the earth. **According to a leading consumer magazine. †Stainless Steel models only.

Feature descriptions can be found in the glossary on pages 134–137. Complete product specifications can be found on page 148.

Electric Cooktops

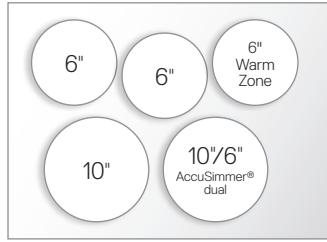

G7CE3055X 30" B | S

Whirlpool Gold® model

5 ceramic glass radiant elements

Warm Zone element

Eco-friendly ceramic glass cooktop*

AccuSimmer® dual radiant element

Dishwasher-safe, stainless steel finish control knobs**

Infinite heat controls



G9CE3065X 30" B | S

Whirlpool Gold® model

AccuSimmer® Plus feature on all elements

Tap Touch controls

Control lock

ADA compliant†

5 ceramic glass radiant elements

Eco-friendly ceramic glass cooktop*

Dual radiant element

Warm Zone element

*Glass cooktop surface manufactured without the release of hazardous metals into the earth. **Stainless Steel models only. †Meets ADA push/pull force and reach guidelines.

Step-up features
highlighted by
yellow bar

Electric Cooktops

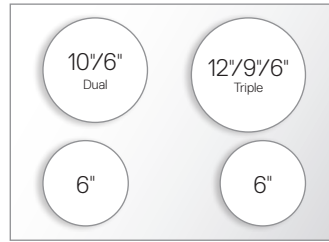

G9CE3074X 30" B

Whirlpool Gold® model

Triple radiant element

Ceramic glass radiant elements

Eco-friendly ceramic glass cooktop*

AccuSimmer® Plus feature on all elements

Tap Touch controls

Dual radiant element

Control lock

ADA compliant†

RATED A
BEST
BUY††



GCI3061X 30" Induction Cooktop B

Whirlpool Gold® model

Boost function element

AccuHeat™ induction technology

Automatic pan detection

Ceramic glass cooktop

Tap Touch controls

Control lock

ADA compliant†

*Glass cooktop surface manufactured without the release of hazardous metals into the earth. †Meets ADA push/pull force and reach guidelines. ††According to a leading consumer magazine.

Feature descriptions can be found in the glossary on pages 134–137. Complete product specifications can be found on pages 148–149.

Electric Cooktops

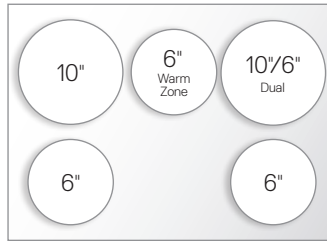

W5CE3625A 36" B

- 5 ceramic glass radiant elements
- Eco-friendly ceramic glass cooktop*
- Dishwasher-safe control knobs
- Dual radiant element
- Warm Zone element
- Infinite heat controls



G7CE3635X 36" B | S

- Whirlpool Gold® model
- AccuSimmer® dual radiant element
- Dishwasher-safe, stainless steel finish control knobs**
- Multiple dual radiant elements
- 5 ceramic glass radiant elements
- Eco-friendly ceramic glass cooktop*
- Warm Zone element
- Infinite heat controls

*Glass cooktop surface manufactured without the release of hazardous metals into the earth. **Stainless Steel models only.

Step-up features
highlighted by
yellow bar

Electric Cooktops

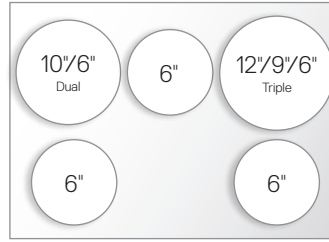

G9CE3675X 36" B | S

Whirlpool Gold® model

AccuSimmer® Plus feature on all elements

Tap Touch controls

Triple radiant element

Control lock

ADA compliant†

5 ceramic glass radiant elements

Eco-friendly ceramic glass cooktop*

Dual radiant element

*Glass cooktop surface manufactured without the release of hazardous metals into the earth. †Meets ADA push/pull force and reach guidelines.

Feature descriptions can be found in the glossary on pages 134–137. Complete product specifications can be found on page 149.

Gas Cooktops



9,100	9,100
10,500	5,000 AccuSimmer®

W3CG3014X 30" W | B | S

Porcelain or stainless steel cooktop
 5,000-BTU AccuSimmer® burner
 Dishwasher-safe, enamel steel grates
 Control knobs
 Sealed burners
 Infinite heat controls
 ADA compliant*



12,500 Power™	9,200
5,000 AccuSimmer®	12,500 Power™

W5CG3024X 30" W | B | S

Dishwasher-safe, full-width cast-iron grates
 Dishwasher-safe control knobs
 Multiple 12,500-BTU Power™ burners
 Porcelain or stainless steel cooktop
 5,000-BTU AccuSimmer® burner
 Sealed burners
 Infinite heat controls
 ADA compliant*

*Meets ADA push/pull force and reach guidelines.

Step-up features
 highlighted by
 yellow bar

Gas Cooktops



9,100	6,000 AccuSimmer®
12,500 Power™	12,500 Power™

GLT3057R 30" B

Whirlpool Gold® model

6,000-BTU AccuSimmer® burner

Tempered glass cooktop

Dishwasher-safe, full-width cast-iron grates

Dishwasher-safe control knobs

Sealed burners

Multiple 12,500-BTU Power™ burners

Infinite heat controls

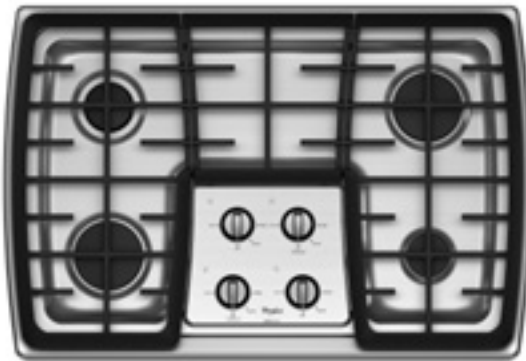

9,200	15,000 Power™
17,000 Power™	5,000 AccuSimmer®

G7CG3064X 30" S

Whirlpool Gold® model

17,000-BTU and 15,000-BTU Power™ burners

Dishwasher-safe, stainless steel finish control knobs

ADA compliant*

Stainless steel cooktop

5,000-BTU AccuSimmer® burner

Dishwasher-safe, full-width cast-iron grates

Sealed burners

Infinite heat controls

NOTE: Cooktop BTUs are listed for each model.

*Meets ADA push/pull force and reach guidelines.

Feature descriptions can be found in the glossary on pages 134–137. Complete product specifications can be found on page 150.

Gas Cooktops



9,200	5,000 AccuSimmer®	9,200
9,200		12,500 Power™

W5CG3625X 36" B | S

Porcelain or stainless steel cooktop
 Dishwasher-safe, full-width cast-iron grates
 Dishwasher-safe control knobs
 Sealed burners
 5,000-BTU AccuSimmer® burner
 12,500-BTU Power™ burner
 Infinite heat controls
 ADA compliant*



6,000 AccuSimmer®	9,100	6,000 AccuSimmer®
12,500 Power™		12,500 Power™

GLT3657R 36" B

Whirlpool Gold® model
 Multiple 6,000-BTU AccuSimmer® burners
 Multiple 12,500-BTU Power™ burners
 Tempered glass cooktop
 Dishwasher-safe, full-width cast-iron grates
 Dishwasher-safe control knobs
 Sealed burners
 Infinite heat controls

*Meets ADA push/pull force and reach guidelines.

Step-up features
 highlighted by
 yellow bar

Gas Cooktops

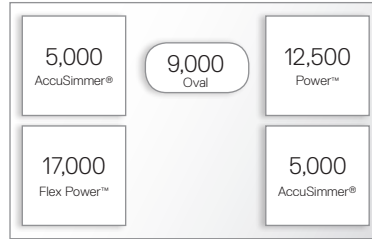

G7CG3665X 36" S

Whirlpool Gold® model

17,000-BTU Flex Power™ burner

Dishwasher-safe, stainless steel finish control knobs

9,000-BTU Oval burner

ADA compliant*

Stainless steel cooktop

Multiple 5,000-BTU AccuSimmer® burners

Dishwasher-safe, full-width cast-iron grates

Sealed burners

12,500-BTU Power™ burner

Infinite heat controls

NOTE: Cooktop BTUs are listed for each model.

*Meets ADA push/pull force and reach guidelines.

Feature descriptions can be found in the glossary on pages 134–137. Complete product specifications can be found on page 150.

Gas Cooktops

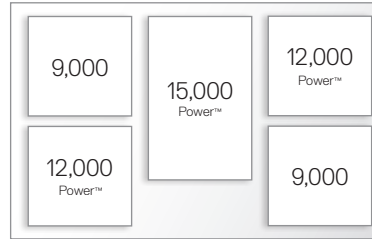
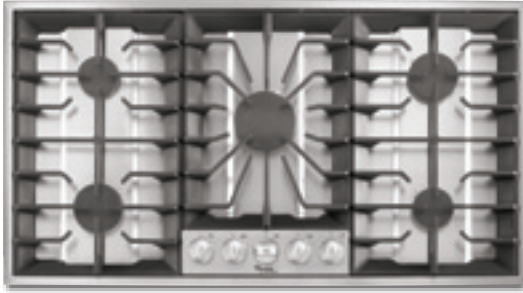

GLS3665R 36" S

Whirlpool Gold® model

15,000-BTU and multiple 12,000-BTU Power™ burners

Recessed grate design

Stainless steel cooktop

Dishwasher-safe, full-width cast-iron grates

Stainless steel finish control knobs

Sealed burners

Infinite heat controls

Step-up features
highlighted by
yellow bar

Modular Cooktop

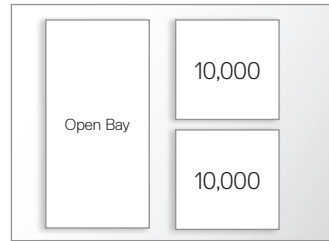

SC8720ED 30" Modular Cooktop B

- Modular porcelain cooktop surface
- Dishwasher-safe, lift-off control knobs
- Infinite heat controls
- Downdraft vent
- Removable/washable vent filter
- Optional modules available: surface burner, non-stick grill and non-stick griddle*

NOTE: Cooktop BTUs are listed for each model.

*Cooktop is shipped with one open bay and two fixed burners. Select from the module options to complete your cooktop

Feature descriptions can be found in the glossary on pages 134–137. Complete product specifications can be found on page 150–151.



WMH53520AE

MICROWAVES



Adjusts cooking time for optimal results

With the push of a single button, Sensor cooking tracks the progress of your food. It automatically adjusts cooking time as needed so you won't have to micro-manage your microwave.



Senses cooktop heat

Select Whirlpool® microwaves automatically adjust fan speed by sensing cooktop heat. Models with the Auto Adapt fan also offer variable fan speeds so you can match the right amount of ventilation to the dish being prepared.



Seals in flavors and juices

TimeSavor™ Plus true convection cooks food evenly with juicy, flavorful results. It uses a rear fan to circulate preheated air over, under and around food.



Convenient steaming

Enjoy flaky fish, tender vegetables and fluffy rice quickly and easily with Steam cooking. Now you can steam in the microwave using the available steamer accessory for delicious, healthy meals.

NOTE: Not all features are available on all models.

Microwave Hood Combinations



WMH31017A 1.7 cu. ft. W | B | D | S

Recessed glass turntable
EZ-View™ lighting



WMH32517A 1.7 cu. ft. W | B | T | S

Sensor cooking
Steam cooking
Recessed, stoppable glass turntable
AccuSimmer® cycle
Cooking rack
EZ-View™ lighting

Step-up features
highlighted by
yellow bar

Microwave Hood Combinations



WMH53520A 2.0 cu. ft. W | B | S | H | E

- Auto Adapt fan
- CleanRelease® non-stick interior
- Sensor cooking
- Steam cooking
- Recessed, stoppable glass turntable
- AccuSimmer® cycle
- Cooking rack
- EZ-View™ lighting



WMH75520A 2.0 cu. ft. W | B | S

- Whirlpool Gold® model
- AccuWave® power system
- Sensor cooking
- Steam cooking
- CleanRelease® non-stick interior
- Recessed, stoppable glass turntable
- AccuSimmer® cycle
- Cooking rack
- EZ-View™ lighting

Feature descriptions can be found in the glossary on pages 134–137. Complete product specifications can be found on page 152.

Microwave Hood Combinations



WMH76718A 1.8 cu. ft. W | B | S

Whirlpool Gold® model

TimeSavor™ Plus true convection

Cooking and convection racks

Sensor cooking

Steam cooking

CleanRelease® non-stick interior

Recessed, stoppable glass turntable

AccuSimmer® cycle

EZ-View™ lighting



GH7208XR 2.0 cu. ft. S

Whirlpool Gold® model

Velos® SpeakCook oven

AccuWave® power system

SpeedCook technology with grilling

Convection and grill racks

Halogen lighting

Touch screen controls

Sensor cooking

TimeSavor™ Plus true convection

Steam cooking

CleanRelease® non-stick interior

Recessed, stoppable glass turntable

AccuSimmer® cycle

Step-up features
highlighted by
yellow bar

Countertop Microwaves



WMC10007A 0.7 cu. ft. W | B

- Turntable
- Electronic touch controls
- Add-a-Minute option
- Control lock



WMC10511A 1.1 cu. ft. W | B

- Sensor cooking
- Large glass turntable
- Add 30 seconds option
- Electronic touch controls
- Control lock

Feature descriptions can be found in the glossary on pages 134–137. Complete product specifications can be found on pages 152–153.

Countertop Microwaves



WMC11511A 1.1 cu. ft. S

- Sensor cooking
- Large glass turntable
- Electronic touch controls
- Add 30 seconds option
- Control lock



WMC30516A 1.6 cu. ft. W | B | S

- Sensor cooking
- Large glass turntable
- Electronic touch controls
- Add 30 seconds option
- Control lock

Step-up features
highlighted by
yellow bar

Countertop Microwaves



WMC20005Y 0.5 cu. ft. W | B | D

- Tap Touch controls
- Rounded-back design
- Glass turntable
- Add 30 seconds option
- Control lock



WMC50522A 2.2 cu. ft. W | B | S

- Sensor cooking
- Large recessed glass turntable
- Electronic touch controls
- Add 30 seconds option
- Control lock

Feature descriptions can be found in the glossary on pages 134–137. Complete product specifications can be found on page 153.

Under Cabinet Hoods



UXT2030AY 30" Traditional W | B

- Up to 190 CFM
- Axial fan
- Top venting only
- Dishwasher-safe grease filter
- 2-speed rocker switch controls
- Incandescent light



UXT3030AY 30" Traditional W | B

- Top and rear venting**
- Up to 190 CFM
- Axial fan
- Dishwasher-safe grease filter
- 2-speed rocker switch controls
- Incandescent light

Step-up features
highlighted by
yellow bar

Under Cabinet Hoods



UXT4030AY 30" Traditional W | B | T | S
UXT4036AY 36" Traditional W | B

- Recirculation kit/Charcoal filter included
- Axial fan
- Recirculating only
- 2-speed rocker switch controls
- Incandescent light



UXT4230AY 30" Traditional W | B | T | S
UXT4236AY 36" Traditional W | B | S

- Up to 225 CFM
- Convertible (recirculating or vented)
- Dishwasher-safe grease filter
- Variable-speed rotary controls
- Adjustable incandescent light
- Axial fan
- Optional Recirculation kit/Charcoal filter

Feature descriptions can be found in the glossary on pages 134–137. Complete product specifications can be found on page 154.

Under Cabinet Hoods



UXT5230AY 30" Traditional W | B | S
UXT5236AY 36" Traditional S

- Up to 350 CFM
- 3-speed push-button controls
- Adjustable halogen light
- Axial fan
- Convertible (recirculating or vented)
- Dishwasher-safe grease filter
- Optional Recirculation kit/Charcoal filter



UXT5530AA 30" High Performance S
UXT5536AA 36" High Performance S

- Up to 400 CFM
- Centrifugal fan
- Multiple dishwasher-safe grease filters
- Recirculation kit/Charcoal filter included
- Convertible (recirculating or vented)
- 3-speed push-button controls
- Adjustable halogen light

Step-up features highlighted by yellow bar



Select Whirlpool® hoods are ENERGY STAR® qualified.

Under Cabinet Hoods



GXU7130DX 30" Traditional S

Whirlpool Gold® model

ENERGY STAR® qualified

Fluorescent light

Up to 300 CFM

Centrifugal fan

Vented only

Multiple dishwasher-safe grease filters

3-speed push-button controls

Feature descriptions can be found in the glossary on pages 134–137. Complete product specifications can be found on page 154.

Canopy Hoods



GXW6530DX 30" Glass Wall Mounted S
GXW6536DX 36" Glass Wall Mounted S

Whirlpool Gold® model
Up to 400 CFM
Centrifugal fan
Convertible (recirculating or vented)
Dishwasher-safe grease filter
3-speed push-button controls
Incandescent light
Optional Recirculation kit/Charcoal filter



UXW6530BS 30" Glass Wall Mounted S
UXW6536BS 36" Glass Wall Mounted S

Up to 400 CFM
Centrifugal fan
Convertible (recirculating or vented)
Dishwasher-safe grease filter
3-speed push-button controls
Incandescent light
Optional Recirculation kit/Charcoal filter

Step-up features highlighted by yellow bar



Select Whirlpool® hoods are ENERGY STAR® qualified.

Canopy Hoods



GXI6536DX 36" Glass Island S

Whirlpool Gold® model

Halogen light

Up to 400 CFM

Centrifugal fan

Convertible (recirculating or vented)

Dishwasher-safe grease filter

3-speed push-button controls

Optional Recirculation kit/Charcoal filter



UXI6536BS 36" Glass Island S

Up to 400 CFM

Centrifugal fan

Convertible (recirculating or vented)

Dishwasher-safe grease filter

3-speed push-button controls

Halogen light

Optional Recirculation kit/Charcoal filter

Feature descriptions can be found in the glossary on pages 134–137. Complete product specifications can be found on page 155.

Canopy Hoods



GXW7230DA 30" Wall Mounted S

Whirlpool Gold® model

Multiple dishwasher-safe grease filters

Up to 400 CFM

Centrifugal fan

Convertible (recirculating or vented)

3-speed push-button controls

Adjustable incandescent light

Optional Recirculation kit/Charcoal filter



UXW7230BS 30" Wall Mounted S

Up to 400 CFM

Centrifugal fan

Convertible (recirculating or vented)

Multiple dishwasher-safe grease filters

3-speed push-button controls

Adjustable incandescent light

Optional Recirculation kit/Charcoal filter

Step-up features highlighted by yellow bar



Select Whirlpool® hoods are ENERGY STAR® qualified.

Canopy Hoods



GXW7330DX 30" Wall Mounted S
GXW7336DX 36" Wall Mounted S

Whirlpool Gold® model

ENERGY STAR® qualified

Fluorescent light

Up to 300 CFM

Centrifugal fan

Convertible (recirculating or vented)

Multiple dishwasher-safe grease filters

3-speed push-button controls

Optional Recirculation kit/Charcoal filter

Feature descriptions can be found in the glossary on pages 134–137. Complete product specifications can be found on page 155.

Downdraft Vent & Hood Liners



UXD8630DY 30" Pop-Up S
UXD8636DY 36" Pop-Up S

Up to 600 CFM
Dual centrifugal fan
Vented only
Multiple dishwasher-safe grease filters
4-speed slider controls



UXL5430BS 30" Hood Liner S

Convertible (recirculating or vented)
Multiple dishwasher-safe grease filters
3-speed push-button controls
Halogen lights
Optional Recirculation kit/Charcoal filter

Step-up features
highlighted by
yellow bar

Hood Liners



UXL6036YS 36" Hood Liner S

- Auto-On Heat sensor
- Additional dishwasher-safe grease filter
- 3-speed slider controls
- Adjustable halogen lights
- Vented only



UXL6048YS 48" Hood Liner S

- Additional dishwasher-safe grease filter
- Auto-On Heat sensor
- Vented only
- 3-speed slider controls
- Adjustable halogen lights

Feature descriptions can be found in the glossary on pages 134–137. Complete product specifications can be found on pages 156–157.

Accessories



affresh® Stainless steel wipes (W10355049)

Disposable wipes gently clean fingerprints, smudges and residue to leave a streak-free, polished shine. Contains 35 use and toss wipes. Size 7" (H) x 9" (W).



affresh® Cooktop cleaner (W10355051) and Replacement Scrubbing Pads (W10391473)

Cuts through tough, baked-on residue. Safe for all glass and ceramic cooktops. Replacement pads used to remove light soil or water spots, 20-pack.



affresh® Stainless steel cleaner (W10355016)

This spray cleaner gently cleans fingerprints, smudges and other residue from Stainless Steel surfaces to leave a streak-free, polished shine.



affresh® Kitchen & appliance cleaner (W10355010)

This spray cleaner cuts through everyday spills to leave a streak-free shine. Easily cleans inside refrigerator and microwave ovens. Now with a fresh, citrus scent.



Gourmet Griddle (4396096RB)

An easy-to-clean, non-stick griddle for electric coil, gas and ceramic glass ranges. Place over two elements or burners for great grilled sandwiches or other dishes.



Microwave Crisper Pan (W10187336A)

Prepare crisp bacon, potatoes or pizza in the microwave with this pan. 12-1/4" (Diameter) and 1-1/2" (Deep).



Baking Stone (4378577)

This 13" baking stone evenly distributes heat and moisture for lighter, crispier food. Suitable for use in regular, convection and microwave ovens.



Universal Microwave Steamer (8205262RB)

Works in tandem with the steaming function to conveniently steam foods such as rice, vegetables and fish with fresh, pleasing results. 13-3/4" (H) x 8-1/2" (W) x 5-1/4" (D).



30" Range Oven Rack (W10273852A)

Replace a standard cooking rack in Whirlpool® double oven ranges with this roll-out rack. Its easy-gliding design makes it simple to retrieve dishes from a hot oven.

Offers enough strength to support two 16-lb turkeys.



Oven Cleaning Kit Retail polybag: W10423113RP Retail box: W10510627RB Factory Certified Parts polybag: W10432017BU

Offers everything you need to clean both gas and electric ovens featuring Aqualift® self-clean technology. Includes (1) scraper, (1) scrubbing sponge and (1) expanding sponge.



Heavy Duty Sliding Rack 30" Wall Ovens: W10282973A 27" Wall Ovens: W10282974A

Heavy Duty Sliding Rack with handle 30" Wall Ovens: W10282971A 27" Wall Ovens: W10282972A



Touch-Up Paint White: 72017 Black: 72032 Biscuit: 4392899 Universal Silver: 8212473

Touch up appliance exteriors with this 0.6 fl. oz. bottle of touch-up paint. Includes applicator brush.

To acquire pricing information, order Whirlpool® cooking accessories and determine delivery time, visit whirlpool.com/accessories or call 1-800-462-3819.

Accessories

Countertop Microwave Accessories

MODEL	WMC30516A
30" Trim Kit*	White - MK2160AW Black - MK2160AB Stainless - MK2160AS
27" Trim Kit*	White - MK2167AW Black - MK2167AB Stainless - MK2167AS

MODEL	WMC30516A
30" Trim Kit cutout dimensions*	15 3/4" (H) x 28 1/2" (W) x 18 1/2" (D)
27" Trim Kit cutout dimensions*	15 3/4" (H) x 25 1/2" (W) x 18 1/2" (D)

Range/Oven Accessories

FILLER KIT	SLIDE-IN/ DROP-IN RANGE	DROP-IN RANGE 6" BACKSPLASH	36" MHC OPENING
White	FILL52WHT	UXA9107AAW	8171336
Black	FILL52BLK	UXA9107AAB	8171337
Biscuit	FILL52BIS	UXA9107AAG	8171338
Stainless	—	JXA912AAP	8171339

MODEL	GY397LXU	GY399LXU	GW397LXU	GW399LXU
Side Panel (White)	UXA1100AAW	UXA1100AAW	UXA1100AAW	UXA1100AAW
Side Panel (Black)	UXA1100AAB	UXA1100AAB	UXA1100AAB	UXA1100AAB
Side Panel (Biscuit)	UXA1100AAG	UXA1100AAG	UXA1100AAG	UXA1100AAG
Side Panel (Stainless)	UXA1100AAS	UXA1100AAS	UXA1100AAS	UXA1100AAS

Microwave Hood Combination Charcoal & Grease Filters

- Replace the charcoal or grease microwave hood filter every 6 months to improve air circulation and remove odors
- Measure current filter to assure correct replacement

AVAILABLE ACCESSORY	DIMENSIONS (L X W X D)
Charcoal filter (8206230A)	5" x 5 1/8" x 3/8"
Grease filters (W10208631)	13 1/2" x 6" x 1/8"
Grease filters (W10113040A)	12 1/4" x 6" x 1/8"

Wall Oven Accessories

MODEL	WOS51EC0/7A WOS51EC0/7A	WOS92EC0/7A WOS92EC0/7A	WOD51EC0/7A WOD51EC0/7A	WOD93EC0/7A WOD93EC0/7A	WOC54EC0/7A WOC54EC0/7A	WOC95EC0A
Side trim cover (left side)	W10344481A	W10344481A	W10327369A	W10327369A	W10344483A	W10344483A
Side trim cover (right side)	W10344480A	W10344480A	W10327368A	W10327368A	W10344482A	W10344482A
FIT system kit (30" model)	Included	Included	Included	Included	W10495947	W10495947
FIT system kit (27" model)	Included	Included	Included	Included	W10495945	N/A

Hood & Vent Charcoal Filters

- Replace the charcoal or grease microwave hood filter every 6 months to improve air circulation and remove odors
- Measure current filter to assure correct replacement

MODEL	DIMENSIONS (L X W X D)	30" MODEL	36" MODEL
Charcoal filter (W10355450)	10 1/2" x 8 3/4" x 1/2"	UXT4030AY UXT4230AY UXT5230AY	UXT4036AY UXT4236AY
Charcoal filter (W10272068)	7 5/8" x 1/8"	UXT5530AA	UXT5536AA
Charcoal filter (W10294730)	7 5/8" x 1/8"	GXW6530DX	GXW6536DX GXI6536DX
Charcoal filter (W10386873)	7 5/8" x 1/8"		UXT5236AY

Hood & Vent Accessories

UNDER CABINET ACCESSORY**	
7" Round damper	W10355451
5', 125V 3-wire Power Cord	W10355452

MODEL	UXT4030AY UXT4036AY	UXT4230AY UXT4236AY	UXT5230AY UXT5236AY	UXT5530AA UXT5536AA	GXW6530DX GXW6536DX	GXI6536DX
Recirculation kit (30")	—	White - 4378581 Black - 4378581 Stainless - 4378581	Black - 49001180 Stainless - 49001196	White - Included Black - Included Stainless - Included	Stainless - W10294733	—
Recirculation kit (36")	—	White - 4378581 Black - 4378581 Stainless - 4378581		White - Included Black - Included Stainless - Included	Stainless - W10294733	Stainless - W10294734
Chimney extension kit					W10294735	W10272078

*Trim kit not available for compact model WMC10007A.
**Accessories listed here are compatible with models UXT4030/36AY, UXT4230/36AY and UXT5230/36AY.

Glossary

AccuBake® temperature management system

Achieve uniform baking results every time with the AccuBake® temperature management system. A built-in sensor monitors oven temperature and controls the cooking elements to deliver consistent, delicious results every time.

AccuHeat™ induction technology

Faster, more efficient cooking is available on select freestanding ranges, cooktops and the industry's first induction double oven freestanding range.* AccuHeat™ induction technology only heats cooking surfaces by transferring energy directly into any cookware with magnetic bases.

AccuSimmer® burner/element

Delivers precise temperature control that is perfect for simmering sauces and soups. Select models feature an AccuSimmer® Plus element that offers more control and reaches your cooktop's lowest temperatures.

AccuSimmer® cycle

Quickly boils liquids in the microwave, then automatically reduces the heat to a delicate simmer to avoid splatters.

AccuWave® power system

Evenly cooks, defrosts, reheats, softens and melts with constant, gentle heat. Thaw chicken without cooking the edges and reheat sauces without splatters.

Add 30 Seconds option

Quickly set the microwave to cook for 30 seconds at 100% power by pressing this button. Or, press it to add 30 seconds to a manual setting that is already in progress.

Adjustable split rack

Remove the rack insert to make room for large items like a turkey or attach it to make a full rack. The insert can also be used on the counter as a cooling rack.

Adjustable time self-cleaning system

Allows for adjustment of the self-clean time in 15-minute intervals, according to your needs.

AquaLift® self-clean technology

Delivers easy, odor-free oven cleaning in only 50 minutes.** Our most energy-efficient self-cleaning cycle available† releases baked-on foods from the bottom of the oven without harsh chemicals or cleaners. When the cleaning cycle is complete, soils and excess water can be easily removed with a dry towel.

Auto Adapt fan

Automatically adjusts fan speed on microwave hood combinations by sensing cooktop heat.

Bridge element

Increases cooking options via a 700-watt bridge element that connects two heating elements. Evenly heat large or oblong pans more easily on the cooktop.

Center griddle

Allows you to warm tortillas, make pancakes or sear fish with a built-in, center griddle.

Ceramic glass cooktop

Withstands intense heat while resisting cracking or chipping, preserving the sleek look of your cooktop for years to come.

CleanRelease® non-stick interior

Reduces cleanup effort because of the non-stick interior—an industry first. No special cleaning solutions are required.

Control Bake

This baking mode keeps the broil element turned off, preventing the tops of your food from overcooking, so pies and turkey come out just right.

Control lock

Disables the control panel to avoid unintended use or other changes to your cooking settings.

Convection Conversion

Removes the guesswork from preparing your favorite dishes by automatically converting standard times and temperatures to the convection equivalent.

Convertible ventilation system

Provides added installation flexibility by venting odors outside or recirculating them, depending upon your preference.

Crisper pan with handle

Provides the ideal cookware for pan-frying foods like bacon or potatoes in the microwave. The patented, non-stick design makes cleanup easy.

Custom Broil

Allows you to set your preferred broiling temperature in 5-degree increments. High heat is best for grilling meats, while low heat is ideal for delicate tasks like melting cheese on lasagna.

Delay Bake

Lets you program the oven to begin cooking at a pre-set time. Prepare food for baking when it's most convenient for you and have dinner ready according to your schedule.

Downdraft vent system

Pulls steam, smoke and odors downward and outside to help clear kitchen air. Conveniently built into select cooktops.

*Among conventional double oven ranges with dual bake and broil elements. **Based on average cleaning time of self-clean cycle with water and moderate soils. †Versus traditional self clean cycle.

Glossary

Dual and Triple radiant elements

Provides the space-saving advantage of having two or three elements in one to handle various sizes of cookware. The inner ring is perfect for simmering or quickly boiling water in small pans. The larger outer ring evenly distributes heat to larger pots and pans for better results.

Eco-friendly ceramic glass cooktop††

Withstands intense heat while resisting cracking or chipping, preserving the sleek look of your cooktop for years to come. The easy-to-clean surface is manufactured without the release of hazardous metals into the earth.

Energy Save mode

Similar to the sleep mode on a computer, the Energy Save feature uses less energy compared to ranges without Energy Save. It can be activated to turn off the display after 5 minutes of the range not being used. Press any button and the display becomes active again.

EZ-View™ lighting

Provides illumination above the range according to your preference with three brightness settings, including a night-light option. Bulbs change out easily when a replacement is needed.

Filter change indicator light

Informs you when it's time to change the microwave hood combination filter so air stays fresher. No more guessing about when you need to change a filter.

FIT system

Now your wall oven can fit seamlessly into your current cabinet cutout‡ with this flexible installation system. It provides various options that are designed to effortlessly suit your decor.

Flex Power™ burner

A 17,000-BTU Flex Power™ burner generates the high heat needed for rapid boiling and searing and provides uniform cooking at lower temperatures for your most delicate dishes, making this our most flexible burner ever.

Frameless door design

Permits easy exterior cleaning with a flat, frameless panel. No nooks or crannies to catch crumbs.

Full-width, cast-iron grates

Offers a smooth design for easy cleaning by hand or in the dishwasher. The grates cover the entire cooktop surface, creating the flexibility to place pots and pans anywhere, while the smooth satin finish resists wear and tear.

Grill rack

Provides the ideal setup when using the grill function of a SpeedCook oven or microwave hood combination, allowing you to place food closer to the grill element for faster cooking. Steaks look and taste as if they were cooked under the oven broiler but are ready in less time.

Hidden bake element

Simplifies cleanup with the bake element hidden beneath the oven floor, leaving a smooth interior surface that is easy to wipe clean.

High-speed coil element

Heats up quickly to provide high temperatures for boiling and frying. Chrome drip pans below catch spills for easy cleanup.

Hot surface indicator

Illuminates when the cooktop surface is still hot to the touch—even after the heating element has been turned off.

Infinite heat controls

Allow for smooth movement of temperature settings, from low to high. Adjust the heat up or down according to your cooking needs.

Kids Menu

Cooks a variety of child-friendly food with preprogrammed cycles that are activated by the simple push of a button. With menu selections like hot dogs and chicken nuggets, children can easily prepare their own pre-game dinners or after-school snacks.

Large/EasyView™ extra-large oven windows

Provides better visibility of the oven interior with a large oven window. Monitor cooking progress without opening the door, keeping oven temperatures steady and undisturbed. Select wall ovens and freestanding ranges feature the EasyView™ extra-large oven window for greater visibility when cooking.

LP Convertible

Can be converted from natural gas to a liquid petroleum fuel source.

Max Capacity recessed rack

Makes room for large items and helps keep food in place while baking.

Melt/Soften cycles

Gently melts foods such as chocolate without cooking (Melt Cycle); gently softens food such as butter without melting (Soften Cycle).

Microwave steamer

Works in tandem with the steaming function to conveniently steam foods such as rice, vegetables and fish with fresh, pleasing results.

Modular cooktop

Allows you to customize the cooking surface according to your needs with gas burners, grill modules and griddle modules.

Most Used cycle

Saves time by remembering and activating your most frequently used Velos® SpeedCook cycle with the simple press of a button.

No Drip chrome drip bowl

Keeps cooking cleanup to a minimum and keeps spills from getting under the cooking surface.

††Glass cooktop surface manufactured without the release of hazardous metals into the earth.

‡Available on 27" and 30" double and single wall ovens. See product specifications for minimum and maximum installation dimensions.

Glossary

One touch bake and broil

Automatically sets the oven to 350°F when the “Bake” button is pushed and 500°F when the “Broil” button is selected.

Oval burner

An elongated central burner that can match oval-shaped pans and other longer cookware. Ideal for cooking oversized dishes on the range top.

Oven Hold Warm/Warm Hold/Keep Warm

Uses low heat to keep food warm inside the oven or microwave, so you can keep completed dishes from getting cold while you work on the rest of your meal.

Pop-up downdraft vent

Variable fan speeds make adjusting the ventilation easy for every situation. Retracts when not in use.

Power™ burners

Generate the high heat needed for rapid boiling, searing and frying with burners that offer up to 17,000 BTUs.

Power “On” indicator

Provides an illuminated reminder that the cooktop is turned on.

Precise Clean® system

Tracks how long it has been since the last self-cleaning cycle and suggests just the right cycle time, so the self-cleaning cycle only lasts as long as necessary for optimal cleaning. No harsh chemicals or cleaners are required.

Preheat countdown timer

Keeps track of how long the oven will take to reach the desired baking temperature with a display that counts down the required time or temperature.

Rapid Boil element

Create your everyday favorite dishes with a flexible cooking element that has the power to take your dishes from an accurate simmer to a rolling boil.

Rapid Preheat option

Preheat the oven 25% faster* with Rapid Preheat. Ideal for single rack baking, this option saves cooking time and energy.

Recessed cooktop

Provides a more aesthetically pleasing profile by lowering the level of the grates.

Sabbath Mode

Overrides the oven's automatic shut-off function, keeping it active for hours of uninterrupted cooking, making it possible to use the oven on the Sabbath without turning it on.

Sealed burners

Cleans up quickly after cooking is complete. No gap between the cooktop and these burners makes for a smooth surface that's easy to clean.

Self-cleaning system (traditional)

Automatically cleans the oven according to a preprogrammed cycle. No harsh chemicals or cleaners are required.

Sensor cooking

Tracks the progress of your food and automatically adjusts the cooking time as needed to deliver optimal results

SpeedCook technology

Cuts cooking time by up to 47% compared to traditional ovens. Microwave technology works with halogen and quartz light energy to grill steaks and bake brownies with real oven results.

SpillGuard™ cooktop

Helps contain messes and makes cleanup easier with the raised-edge design.

Split rack

Remove the rack insert to make room for large or tall items, or attach it to make a full rack.

Staged cooking

Allows you to custom program multiple power levels and cooking durations without keeping watch over the microwave. Ideal for dishes requiring temperature changes mid-cooking, like frozen entrees.

SteamClean option

Clean up every day light spills using heat and only 1-1/4 cups of water—no harsh chemicals or cleaners needed.

Steam cooking

Conveniently steams foods such as rice, vegetables and fish in conjunction with the patented microwave steamer.

Tap Touch controls

Provide a sleek, sophisticated look that is easy to clean. Cooktop controls can be set with a simple touch.

TimeSavor™ convection

Uses a fan in the back of the oven to distribute hot air more efficiently for crispier, juicier and tastier results.

*Single rack baking with Rapid Preheat option versus three-rack without option.

Glossary

TimeSavor™ Plus true convection

Uses a fan plus a third heating element in the oven or microwave to distribute hot air more efficiently and seal in flavor and juices on every rack. Select microwaves use a rear fan to also cut roasting time compared to traditional thermal-bake ovens.

TimeSavor™ Ultra true convection

TimeSavor™ Ultra true convection uses a rear fan, a third 2,500-watt heating element and an innovative X-shaped baffle to distribute heated air more efficiently in four directions.

Touch screen controls

Features dozens of step-by-step directions on a digital display for simple, accurate cooking in the microwave.

TruCapture® ventilation system

Removes cooktop smoke, steam and odors from the front two burners with a powerful 4-speed fan and unique, sloped design that vents out the top instead of the front of the unit. Whirlpool brand's most efficient ventilation system.

Velos® SpeedCook oven

Microwave hood combination oven that grills, bakes, steams, microwaves and vents, featuring SpeedCook technology as well as the TruCapture® ventilation system.

Warming drawer

Keeps food and dinnerware warm in a separate, heated drawer. Multiple temperature settings provide flexibility and help ensure that food done ahead of schedule doesn't get cold before the entire meal is ready to serve.

Warm Zone element

Prevents food from cooling while the rest of the meal is being prepared. This low-powered (20–100 watt) fifth element provides added flexibility and convenience.

Washable filter

Dishwasher-safe filters trap unwanted grease and odors and wash easily for re-use.

Freestanding Double Oven Electric Ranges

SPECIFICATIONS AND DIMENSIONS

MODEL	WHIRLPOOL®		WHIRLPOOL GOLD®
	WGE555S0B	WGE755C0B	WGI925C0B INDUCTION
New 2013 model	.	.	.
Oven capacity (cu. ft.)	2.5 Upper 4.2 Lower	2.5 Upper 4.2 Lower	2.5 Upper 4.2 Lower
Total capacity (cu. ft.)	6.7	6.7	6.7
Recommended MHC	WMH53520A	WMH53520A	WMH75520A
Electronic oven controls	.	.	.
Designed, engineered and assembled in the U.S.A.	.	.	.
CONVENIENCE FEATURES (BOTH OVENS)			
AccuBake® temperature management system	.	.	.
Precise Clean™ self-cleaning system	.	.	.
SteamClean option	.	◆	.
Hidden bake element	.	◆	.
Rapid Preheat (default)	.	.	.
Delay Bake	.	.	.
Broil	.	.	.
Keep Warm	.	.	.
Sabbath Mode	.	.	.
Control lock	.	.	.
Clock and timer display color	Blue	Blue	Blue
Automatic oven light	.	.	.
UPPER OVEN FEATURES			
Adjustable rack	1	1	1
Rack positions	2	2	2
Large oven window	.	.	.
LOWER OVEN FEATURES			
TimeSavor™ Plus true convection	.	◆	.
TimeSavor™ convection	.	.	.
Adjustable racks	2	2	2
Rack positions	5	5	5
EasyView™ extra-large oven window	.	.	.
COOKTOP FEATURES			
AccuHeat™ induction technology	.	.	◆
Ceramic glass cooktop	Eco-friendly*	Eco-friendly*	.
Upswept SpillGuard™ cooktop	.	.	.
Element type	Radiant	Radiant	Induction
Left rear element	6" Melt	6" Melt	11" Boost
Right rear element	6"	6"	6" Boost
Left front element	9"/6" dual	12"/6" dual	6" Boost
Right front element	10"	10" Rapid Boil	7" Boost
Center element	6.7" Warm Zone	6.7" Warm Zone	.
DIMENSIONS AND COLORS			
Cutout height (A)	36"	36"	36"
Cutout width (B)	30 ¹ / ₈ "	30 ¹ / ₈ "	30 ¹ / ₈ "
Cutout depth (C)	24"	24"	24"
Overall height (D)	47 ¹ / ₄ "	47 ¹ / ₄ "	47 ¹ / ₄ "
Height to maintop (E)	35 ³ / ₄ "	35 ³ / ₄ "	35 ³ / ₄ "
Overall width (F)	29 ⁹ / ₁₆ "	29 ⁹ / ₁₆ "	29 ⁹ / ₁₆ "
Depth without handle (G)	27 ¹ / ₄ "	27 ¹ / ₄ "	27 ¹ / ₄ "
Depth with handle	28 ¹ / ₂ "	28 ¹ / ₂ "	28 ¹ / ₂ "
Depth with door open 90°	46"	46"	46"
Available colors	W B S	S H E	S

Bold type indicates a step-up feature

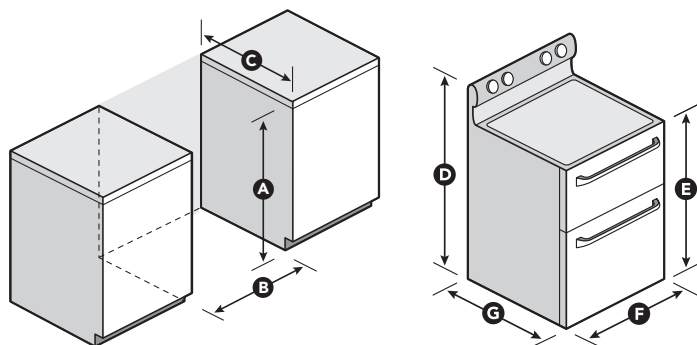

* Glass cooktop surface manufactured without the release of hazardous metals into the earth.

DIMENSIONS ARE SHOWN FOR PLANNING PURPOSES ONLY.
For complete information, see Installation Instructions packed with product.

Freestanding Double Oven Gas Ranges

SPECIFICATIONS AND DIMENSIONS

	WHIRLPOOL®	WHIRLPOOL GOLD®
MODEL	WGG55S0B	WGG75S0B
New 2013 model	-	-
Oven capacity (cu. ft.)	2.1 Upper 3.9 Lower	2.1 Upper 3.9 Lower
Total capacity (cu. ft.)	6.0	6.0
Recommended MHC	WMH53520A	WMH53520A
Electronic oven controls	-	-
Designed, engineered and assembled in the U.S.A.	-	-
CONVENIENCE FEATURES (BOTH OVENS)		
AccuBake® temperature management system	-	-
Precise Clean™ self-cleaning system	-	-
Hidden bake element	-	-
Delay Bake	-	-
Keep Warm	-	-
Sabbath Mode	-	-
Control lock	-	-
Clock and timer display color	Blue	Blue
Automatic oven light	-	-
LP Convertible	-	-
UPPER OVEN FEATURES		
Broil	-	-
Adjustable rack	1	1
Rack positions	2	2
Large oven window	-	-
LOWER OVEN FEATURES		
TimeSaver™ convection	-	◆
Adjustable racks	2	2
Rack positions	5	5
EasyView™ extra-large oven window	-	-
COOKTOP FEATURES		
Full-width, satin-finish cast-iron grates	-	-
Left rear element/burner	5,000 BTU AccuSimmer®	5,000 BTU AccuSimmer®
Right rear element/burner	9,200 BTU	5,000 BTU AccuSimmer®
Left front element/burner	15,000 BTU Power™	16,000 BTU Power™
Right front element/burner	9,200 BTU	10,000 BTU
Center element/burner	-	7,350 BTU Oval
DIMENSIONS AND COLORS		
Cutout height (A)	36"	36"
Cutout width (B)	30 ¹ / ₄ "	30 ¹ / ₄ "
Cutout depth (C)	24"	24"
Overall height (D)	47 ¹ / ₄ "	47 ¹ / ₄ "
Height to maintop (E)	35 ³ / ₄ "	35 ³ / ₄ "
Overall width (F)	29 ⁵ / ₈ "	29 ⁵ / ₈ "
Depth without handle (G)	27 ¹ / ₄ "	27 ¹ / ₄ "
Depth with handle	28 ¹ / ₂ "	28 ¹ / ₂ "
Depth with door open 90°	46"	46"
Available colors	W B S	S H E

Bold type indicates a step-up feature

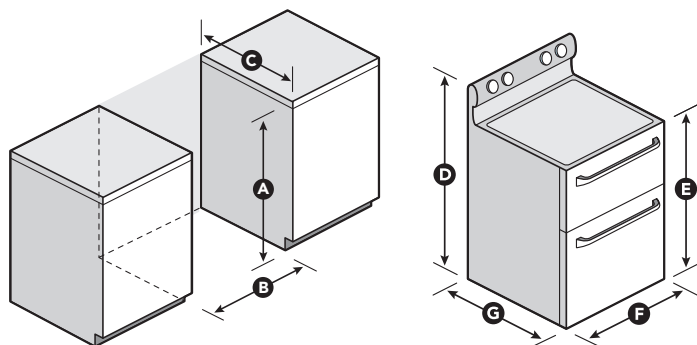

DIMENSIONS ARE SHOWN FOR PLANNING PURPOSES ONLY.
For complete information, see Installation Instructions packed with product.

Freestanding Electric Ranges

SPECIFICATIONS AND DIMENSIONS

WHIRLPOOL®				
MODEL	WFC130M0A	WFC340S0A	WFC310S0A	WFE320M0A
Capacity (cu. ft.)	4.8	4.8	4.8	4.8
Recommended MHC	WMH31017A	WMH31017A	WMH31017A	WMH31017A
Oven controls	Electronic	Knob	Electronic	Electronic
Metal handle*		♦		♦
ADA compliant**		♦		
Designed, engineered and assembled in the U.S.A.
OVEN FEATURES				
AccuBake® temperature management system			♦	
Traditional self-cleaning system		♦	.	.
Delay Bake			♦	
Keep Warm			♦	
Custom Broil
Sabbath Mode	.	.	♦	.
Control lock	.	.	♦	.
Clock and timer display color	Blue		Blue	Blue
Oven light
Total adjustable racks	2	2	2	2
Oven window	Standard	Large	Large	Large
Lower drawer	Storage	Storage	Storage	Storage
COOKTOP FEATURES				
Eco-friendly ceramic glass cooktop†				♦
Upswept porcelain SpillGuard™ cooktop	.	.	.	
Element type	Coil	Coil	High-speed coils	Radiant
Left rear element	6" 1,250-watt	6" 1,250-watt	6" 1,500-watt high speed	6" 1,200-watt
Right rear element	8" 2,100-watt	8" 2,100-watt	8" 2,600-watt high speed	6" 1,200-watt
Left front element	8" 2,100-watt	8" 2,100-watt	8" 2,600-watt high speed	9"/6" 3,000-watt dual
Right front element	6" 1,250-watt	6" 1,250-watt	6" 1,500-watt high speed	9" 2,500-watt
DIMENSIONS AND COLORS				
Cutout height (A)	36"	36"	36"	36"
Cutout width (B)	30"	30"	30"	30"
Cutout depth (C)	24"	24"	24"	24"
Overall height (D)	46 1/8"	46 1/8"	46 1/8"	46 1/8"
Height to maintop (E)	36"	36"	36"	36"
Overall width (F)	29 1/8"	29 1/8"	29 1/8"	29 1/8"
Overall depth (G)	27 3/4"	27 3/4"	27 3/4"	27 3/4"
Depth without handle	25 1/8"	25 1/8"	25 1/8"	25 1/8"
Depth with door open 90°	46 1/16"	46 1/16"	46 1/16"	46 1/16"
Available colors	W B	W B S	W B S	W B S

Bold type indicates a step-up feature

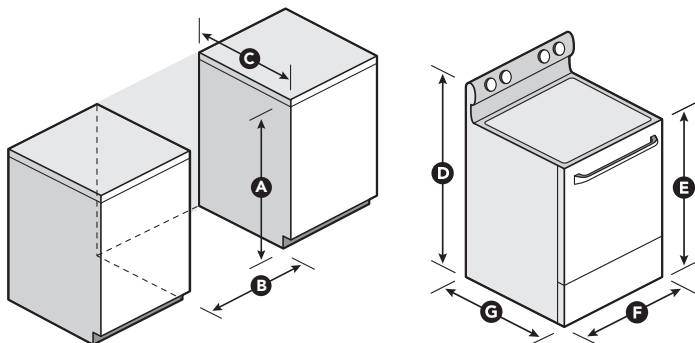

*Available on Stainless Steel models only. **Model meets applicable ADA requirements and must be installed in compliance with the current ADA Standards. †Glass cooktop surface manufactured without the release of hazardous metals into the earth.

DIMENSIONS ARE SHOWN FOR PLANNING PURPOSES ONLY.
For complete information, see Installation Instructions packed with product.

Freestanding Electric Ranges

SPECIFICATIONS AND DIMENSIONS

MODEL	WHIRLPOOL®		WHIRLPOOL GOLD®		
	WFE510S0A	WFE540H0A	WFE710H0A	WFE720H0A	WFI910H0A INDUCTION
Capacity (cu. ft.)	4.8	6.2	6.2	6.2	6.2
Recommended MHC	WMH32517A	WMH53520A	WMH53520A	WMH53520A	WMH53520A
Oven controls	Electronic	Electronic	Electronic	Electronic	Tap Touch††
Metal handle*
Designed, engineered and assembled in the U.S.A.
OVEN FEATURES					
AccuBake® temperature management system	♦
AquaLift® self-clean technology		♦	.	.	.
Traditional self-cleaning system	♦				
Hidden bake element		with thermal vents	with thermal vents	with thermal vents	with thermal vents
TimeSavor™ Plus true convection			♦	.	.
TimeSavor™ convection		♦			
Convection Conversion			♦	.	.
Energy Save mode		♦	.	.	.
Rapid Preheat			♦	.	.
Delay Bake		♦	.	.	.
Keep Warm		♦	.	.	.
Custom Broil
Sabbath Mode
Control lock
Clock and timer display color	Blue	Blue	Blue	Blue	Blue
Oven light
Total adjustable racks	2	2	3	3	3
Max Capacity recessed rack		♦	.	.	.
Adjustable split rack			♦	.	.
Oven window	Large	EasyView™ extra-large	EasyView™ extra-large	EasyView™ extra-large	EasyView™ extra-large
Lower drawer	Storage	Storage	Storage	High/Med/Low warming with handle	High/Med/Low warming with handle
COOKTOP FEATURES					
AccuHeat™ induction technology					♦
Ceramic glass cooktop	Eco-friendly†	Eco-friendly†	Eco-friendly†	Eco-friendly†	.
Element type	Radiant	Radiant	Radiant	Radiant	Induction
Left rear element	6" 1,200-watt	6" 1,200-watt	6" 300/1,300-watt AccuSimmer®	6" 300/1,300-watt AccuSimmer®	9" 3,200-watt Boost
Right rear element	6" 1,200-watt	6" 1,200-watt	6" 1,200-watt	6" 1,200-watt	11" 3,700-watt Boost
Left front element	9" 6" 3,000-watt dual	12" 9" 3,000-watt dual	12" 9" 3,000-watt dual	12" 9" 6" 3,000-watt triple	6" 1,800-watt Boost
Right front element	9" 2,500-watt	9" 6" 3,000-watt dual	9" 6" 3,000-watt dual	10" 3,200-watt Rapid Boil	6" 1,800-watt Boost
Center rear element		6" 100-watt Warm Zone	6" 100-watt Warm Zone	6" 100-watt Warm Zone	
DIMENSIONS AND COLORS					
Cutout height (A)	36"	36"	36"	36"	36"
Cutout width (B)	30"	30"	30"	30"	30"
Cutout depth (C)	24"	24"	24"	24"	24"
Overall height (D)	46 ⁷ / ₈ "	46 ⁷ / ₈ "	46 ⁷ / ₈ "	46 ⁷ / ₈ "	46 ⁷ / ₈ "
Height to maintop (E)	36"	36"	36"	36"	36"
Overall width (F)	29 ⁷ / ₈ "	29 ⁷ / ₈ "	29 ⁷ / ₈ "	29 ⁷ / ₈ "	29 ⁷ / ₈ "
Overall depth (G)	27 ³ / ₄ "	27 ³ / ₄ "	27 ³ / ₄ "	27 ³ / ₄ "	27 ³ / ₄ "
Depth without handle	25 ⁵ / ₈ "	25 ⁵ / ₈ "	25 ⁵ / ₈ "	25 ⁵ / ₈ "	25 ⁵ / ₈ "
Depth with door open 90°	46 ¹¹ / ₈ "	47 ¹³ / ₈ "	47 ¹³ / ₈ "	47 ¹³ / ₈ "	47 ¹³ / ₈ "
Available colors	W B T D S	W B S H E	S H E	S	S

Bold type indicates a step-up feature

*Available on Stainless Steel models only. †Glass cooktop surface manufactured without the release of hazardous metals into the earth. ††Cooktop only.

DIMENSIONS ARE SHOWN FOR PLANNING PURPOSES ONLY.
For complete information, see Installation Instructions packed with product.

Freestanding Gas Ranges

SPECIFICATIONS AND DIMENSIONS

MODEL	WHIRLPOOL®				WHIRLPOOL GOLD®		
	WFG114SW	WFG231LV	WFG510S0A	WFG520S0A	WFG540H0A	WFG710H0A	WFG720H0A
Capacity (cu. ft.)	4.4	4.4	5.0	5.0	5.8	5.8	5.8
Recommended MHC	WMH31017A	WMH31017A	WMH32517A	WMH53520A	WMH53520A	WMH53520A	WMH53520A
Oven controls	Electronic	Electronic	Electronic	Electronic	Electronic	Electronic	Electronic
Metal handle*			◆	•	•	•	•
Designed, engineered and assembled in the U.S.A.			◆	•	•	•	•
OVEN FEATURES							
AccuBake® temperature management system			◆	•	•	•	•
AquaLift® self-clean technology					◆	•	•
Traditional self-cleaning system			◆	•			
TimeSavor™ Plus true convection							◆
TimeSavor™ convection					◆	•	
Convection Conversion						◆	•
Energy Save					◆	•	•
Rapid Preheat						◆	•
Delay Bake			◆	•	•	•	•
Keep Warm			◆	•	•	•	•
Custom Broil	•	•	•	•	•	•	•
Sabbath Mode			◆	•	•	•	•
Control lock			◆	•	•	•	•
Clock and timer display color	Blue green	Blue green	Blue	Blue	Blue	Blue	Blue
Oven light	•	•	•	•	•	•	•
Total adjustable racks	2	2	2	2	2	3	3
Max Capacity recessed rack					◆	•	•
Adjustable split rack						◆	•
Oven window	Standard	Large	Large	Large	EasyView™ extra-large	EasyView™ extra-large	EasyView™ extra-large
Lower drawer	Broiler	Broiler	Storage	Storage	Storage	Storage	High/Med/Low warming with handle
LP Convertible (kit included)	•	•	•	•	•	•	•
COOKTOP FEATURES							
Included griddle		Center				Side integrated	Side integrated
Recessed cooktop			◆	•	•	•	•
Burner grates	Cast-iron	Cast-iron	Satin-finish, cast-iron	Full-width, satin-finish, cast-iron	Full-width, satin-finish, cast-iron	Full-width, satin-finish, cast-iron	Full-width, satin-finish, cast-iron
Left rear burner	9,500 BTU	7,000 BTU	9,500 BTU	9,500 BTU	9,500 BTU	9,500 BTU	9,500 BTU
Right rear burner	9,500 BTU	7,000 BTU	5,000 BTU AccuSimmer®	5,000 BTU AccuSimmer®	5,000 BTU AccuSimmer®	5,000 BTU AccuSimmer®	5,000 BTU AccuSimmer®
Left front burner	11,500 BTU	8,000 BTU	13,500 BTU Power™	15,000 BTU Power™	17,000 BTU Power™	17,000 BTU Power™	17,000 BTU Power™
Right front burner	9,500 BTU	7,000 BTU	9,500 BTU	15,000 BTU Power™	15,000 BTU Power™	15,000 BTU Power™	15,000 BTU Power™
Center burner		7,500 BTU Oval			8,000 BTU Middle	8,000 BTU Middle	8,000 BTU Middle
DIMENSIONS AND COLORS							
Cutout height (A)	36"	36"	36"	36"	36"	36"	36"
Cutout width (B)	30"	30"	30"	30"	30"	30"	30"
Cutout depth (C)	24"	24"	24"	24"	24"	24"	24"
Overall height (D)	46 1/4"	46 1/4"	46 7/8"	46 7/8"	46 7/8"	46 7/8"	46 7/8"
Height to maintop (E)	36"	36"	36"	36"	36"	36"	36"
Overall width (F)	29 7/8"	29 7/8"	29 7/8"	29 7/8"	29 7/8"	29 7/8"	29 7/8"
Overall depth (G)	26 3/4"	25 3/4"	27 1/4"	27 1/4"	27 1/4"	27 1/4"	27 1/4"
Depth without handle	24 1/4"	24 1/4"	25 7/16"	25 7/16"	25 7/16"	25 7/16"	25 7/16"
Depth with door open 90°	42 1/8"	42 1/8"	46 9/16"	46 9/16"	47 15/16"	47 15/16"	47 15/16"
Available colors	Q B	Q B S	W B T D S	W B S	W B S H E	S H E	S

Bold type indicates a step-up feature

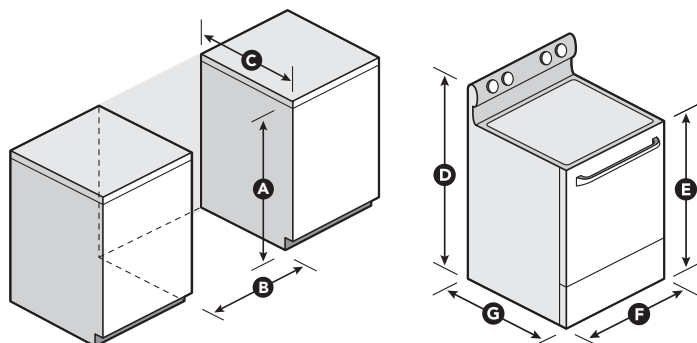

*Available on Stainless Steel models only.

DIMENSIONS ARE SHOWN FOR PLANNING PURPOSES ONLY.
For complete information, see Installation Instructions packed with product.

Slide-In Ranges

SPECIFICATIONS AND DIMENSIONS

MODEL	WHIRLPOOL®		WHIRLPOOL GOLD®		
	RY160LXT ELECTRIC	GY397LXU ELECTRIC	GY399LXU ELECTRIC	GW397LXU GAS	GW399LXU GAS
Capacity (cu. ft.)	4.3	4.5	4.5	4.5	4.5
Recommended MHC	WMH3205XV	WMH75520A	WMH76718A	WMH75520A	WMH76718A
Metal handle*		♦	•	•	•
ADA compliant**					
Designed, engineered and assembled in the U.S.A.	•	•	•	•	•
OVEN FEATURES					
AccuBake® temperature management system		♦	•	•	•
Precise Clean™ self-cleaning system	•	•	•	•	•
Hidden bake element			♦	•	•
TimeSavor™ Plus true convection			♦		♦
Delay Bake		♦	•	•	•
Warm Hold	•	•	•	•	•
Sabbath Mode	•	•	•	•	•
Control lock	•	•	•	•	•
Clock and timer display color	Blue	Blue	Blue	Blue	Blue
Automatic oven light		♦	•	•	•
Raised ergonomic console		♦	•	•	•
Total adjustable racks	2	2	2	2	2
Adjustable split rack			♦		♦
Extra-large oven window	•	•	•	•	•
Storage drawer	•	•	•	•	•
Frameless door design		♦	•	•	•
LP Convertible				•	•
COOKTOP FEATURES					
Eco-friendly ceramic glass cooktop†		♦	•		
Recessed cooktop				•	•
Element type	Coil	Radiant	Radiant		
Continuous, satin-finish, cast-iron grates				•	•
Left rear element/burner	8"	9"/6" dual	9"/6" dual	5,000 BTU	5,000 BTU
Right rear element/burner	6"	6"	6"	9,200 BTU	9,200 BTU
Left front element/burner	6"	6"	6"	9,200 BTU	12,500 BTU Power™
Right front element/burner	8"	9"/6" dual	12"/9" dual	14,000 BTU Power™	16,000 BTU Power™
ACCESSORIES					
Filler Strip	W10113931 (Q) W10113902A (B) W10113901A (S)	W10113931 (Q) W10113902A (B) W10113901A (S)	W10113931 (Q) W10113902A (B) W10113901A (S)	W10113931 (Q) W10113902A (B) W10113901A (S)	W10113931 (Q) W10113902A (B) W10113901A (S)
DIMENSIONS AND COLORS					
Cutout width (A)	30"	30"	30"	30"	30"
Cutout depth (B)	23 1/4"	23 1/4"	23 1/4"	23 1/4"	23 1/4"
Height (C)	35 3/4"	35 3/4"	35 3/4"	35 3/4"	35 3/4"
Base width (D)	29 7/8"	29 7/8"	29 7/8"	29 7/8"	29 7/8"
Depth (E)	28 7/8"	28 3/4"	28 3/4"	28 3/4"	28 3/4"
Available colors	Q B S	Q B S	Q B S	Q B S	Q B S

Bold type indicates a step-up feature

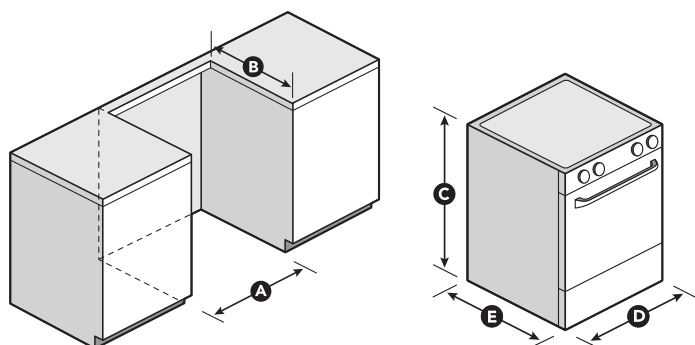

*Available on Stainless Steel models only. **Model meets applicable ADA requirements and must be installed in compliance with the current ADA Standards.
†Glass cooktop surface manufactured without the release of hazardous metals into the earth.

DIMENSIONS ARE SHOWN FOR PLANNING PURPOSES ONLY.
For complete information, see Installation Instructions packed with product.

Drop-In Electric Ranges

SPECIFICATIONS AND DIMENSIONS

WHIRLPOOL®			
MODEL	WDE150LV	WDE350LV	WDE350LV
Capacity (cu. ft.)	4.5	4.5	4.5
Recommended MHC	WMH2175XV	WMH75520A	WMH75520A
Metal handle*	.	.	.
Designed, engineered and assembled in the U.S.A.	.	.	.
OVEN FEATURES			
AccuBake® temperature management system	.	.	.
Self-cleaning system with Delay Clean	.	.	.
Delay Bake	.	.	.
Oven Hold Warm	.	.	.
Sabbath Mode	.	.	.
Control lock	.	.	.
Timer display color	Blue	Blue	Blue
Oven light	.	.	.
Adjustable racks	2	2	2
Large oven window	.	.	.
Frameless door design	.	.	.
COOKTOP FEATURES			
Eco-friendly ceramic glass cooktop**			♦
Element type	Coil		Radiant
Left rear element	8"		9"/6" dual
Right rear element	6"		6"
Left front element	6"		6"
Right front element	8"		9"/6" dual
DIMENSIONS AND COLORS			
Cutout width (A)	30"		30"
Cutout depth (B)	23 1/4"		23 1/4"
Countertop height (C)	27 1/2"		27 1/2"
Height (D)	28 1/2"		28 1/2"
Base width (E)	29 7/8"		29 7/8"
Recessed depth (F)	26 1/4"		26 1/4"
Available colors	Q B S		Q B S

Bold type indicates a step-up feature

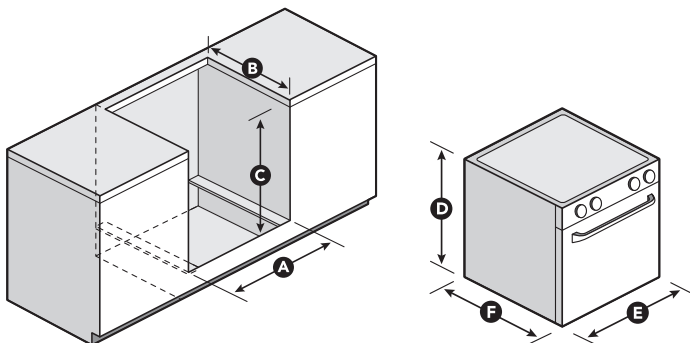

*Available on Stainless Steel models only. **Glass cooktop surface manufactured without the release of hazardous metals into the earth.

DIMENSIONS ARE SHOWN FOR PLANNING PURPOSES ONLY.
For complete information, see Installation Instructions packed with product.

Single Wall Ovens

SPECIFICATIONS AND DIMENSIONS

	WHIRLPOOL®		WHIRLPOOL GOLD®
MODEL	RBS245PR	WOS51EC0A	WOS92EC0A
Size	24"	30"	30"
Also available in 27"		WOS51EC7A	WOS92EC7A
Capacity (cu. ft.)	3.1	5.0 / 4.3	5.0 / 4.3
Recommended cooktops	W5CE3024X W5CG3024X	W5CE3024X W5CG3024X	G9CE3065X G7CG3064X
Metal handle		♦	.
Designed, engineered and assembled in the U.S.A.	.	.	.
OVEN FEATURES			
AccuBake® temperature management system	.	.	.
Precise Clean™ self-cleaning system		♦	.
Self-cleaning system	.		.
SteamClean option		♦	.
Hidden bake element		♦	.
TimeSaver™ Ultra true convection			♦
Convection Conversion			♦
Rapid Preheat			♦
Preheat countdown	Timer	Temperature	Temperature
Delay Bake	.	.	.
Hold Warm		♦	.
Custom Broil		♦	.
Closed door broiling	.	.	.
Sabbath Mode		♦	.
Control lock	.	.	.
Illuminated display (two-color)	.	.	.
Oven light	Incandescent	Incandescent	Incandescent
Total adjustable racks	2	2	3
Oven window	Large	EasyView™ extra-large	EasyView™ extra-large
FIT system		♦	.
Approved for under-the-counter installation	.	.	.
GENERAL INFORMATION			
Bake element watts at 240/208 volts	2000W/1500W	2800W/2427W	2800W/2427W
Broil element watts at 240/208 volts	3000W/2250W	3600W/3120W	3600W/3120W
Convection element watts at 240/208 volts			2500W/2167W
Circuit amperage	30 Amps	30 Amps	30 Amps
Total connected load at 240 volts	5 kW	3.7 kW	3.7 kW
Total connected load at 208 volts	3.8 kW	2.8 kW	2.8 kW
24" Oven cavity size (H x W x D)	16" x 19" x 17 ⁵ / ₈ "		
27" Oven cavity size (H x W x D)		18" x 22" x 19"	18" x 22" x 19"
30" Oven cavity size (H x W x D)		18" x 25" x 19"	18" x 25" x 19"
DIMENSIONS AND COLORS			
Cutout height (A)	27 ³ / ₄ "	26 ¹⁵ / ₁₆ "–29 ⁷ / ₁₆ "	26 ¹⁵ / ₁₆ "–29 ⁷ / ₁₆ "
Cutout width (B)	22 ¹ / ₂ "	28 ¹ / ₂ " / 25 ¹ / ₂ "	28 ¹ / ₂ " / 25 ¹ / ₂ "
Cutout depth (C)	23 ¹ / ₄ "	24"	24"
Overall height (D)	29"	28 ³ / ₄ "	28 ³ / ₄ "
Overall width (E)	23 ³ / ₄ "	30" / 27"	30" / 27"
Overall depth (F)	26"	26 ³ / ₈ "	26 ³ / ₈ "
Available colors (24" and 30" models)	Q B S	W B T S	B S H E
Available colors (27" models)		W B S	W B S

Bold type indicates a step-up feature

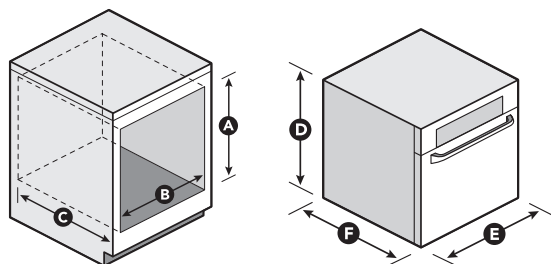

DIMENSIONS ARE SHOWN FOR PLANNING PURPOSES ONLY.
For complete information, see Installation Instructions packed with product.

Double Wall Ovens

SPECIFICATIONS AND DIMENSIONS

	WHIRLPOOL®		WHIRLPOOL GOLD®
MODEL	RBD245PR	WOD51EC0A	WOD93EC0A
Size	24"	30"	30"
Also available in 27"		WOD51EC7A	WOD93EC7A
Oven capacity (cu. ft.)	3.1 Upper 3.1 Lower	5.0 / 4.3 Upper 5.0 / 4.3 Lower	5.0 / 4.3 Upper 5.0 / 4.3 Lower
Total capacity (cu. ft.)	6.2	10.0 / 8.6	10.0 / 8.6
Recommended cooktops	W5CE3024X W5CG3024X	W5CE3024X W5CG3024X	G9CE3074X G7CG3064X
Metal handles		♦	.
Designed, engineered and assembled in the U.S.A.	.	.	.
OVEN FEATURES			
AccuBake® temperature management system	.	.	.
Precise Clean™ self-cleaning system		♦	.
Self-cleaning system	Upper only		
SteamClean option		♦	.
Hidden bake element		♦	.
TimeSavor™ Ultra true convection			Upper only
Convection Conversion			Upper only
Rapid Preheat			♦
Preheat countdown	Timer	Temperature	Temperature
Delay Bake	.	.	.
Hold Warm		♦	.
Custom Broil		♦	.
Closed door broiling	.	.	.
Sabbath Mode		♦	.
Control lock	.	.	.
Illuminated display (two-color)	.	.	.
Oven lights	Incandescent	Incandescent	Incandescent
Total adjustable racks	2 Upper / 2 Lower	2 Upper / 2 Lower	3 Upper / 2 Lower
Oven window	Large	EasyView™ extra-large	EasyView™ extra-large
FIT system		♦	.
GENERAL INFORMATION			
Bake element watts at 240/208 volts	2000W/1500W	2800W/2427W	2800W/2427W
Broil element watts at 240/208 volts	3000W/2250W	3600W/3120W	3600W/3120W
Convection element watts at 240/208 volts			2500W/2167W
Circuit amperage	40 Amps	40 Amps	40 Amps
Total connected load at 240 volts	8 kW	7.4 kW	7.4 kW
Total connected load at 208 volts	6 kW	5.6 kW	5.6 kW
24" Oven cavity size (H x W x D)	16" x 19" x 17 ⁵ / ₈ "		
27" Oven cavity size (H x W x D)		18" x 22" x 19"	18" x 22" x 19"
30" Oven cavity size (H x W x D)		18" x 25" x 19"	18" x 25" x 19"
DIMENSIONS AND COLORS			
Cutout height (A)	49 ³ / ₄ "	48 ⁷ / ₈ "–52 ³ / ₈ "	48 ⁷ / ₈ "–52 ³ / ₈ "
Cutout width (B)	22 ¹ / ₂ "	28 ¹ / ₂ " / 25 ¹ / ₂ "	28 ¹ / ₂ " / 25 ¹ / ₂ "
Cutout depth (C)	23 ¹ / ₄ "	24"	24"
Overall height (D)	51"	51 ¹ / ₈ "	51 ¹ / ₈ "
Overall width (E)	23 ³ / ₄ "	30" / 27"	30" / 27"
Overall depth (F)	26"	26 ³ / ₈ "	26 ³ / ₈ "
Available colors (24" and 30" models)	Q B S	W B S	B S H E
Available colors (27" models)		W B S	W B S

Bold type indicates a step-up feature

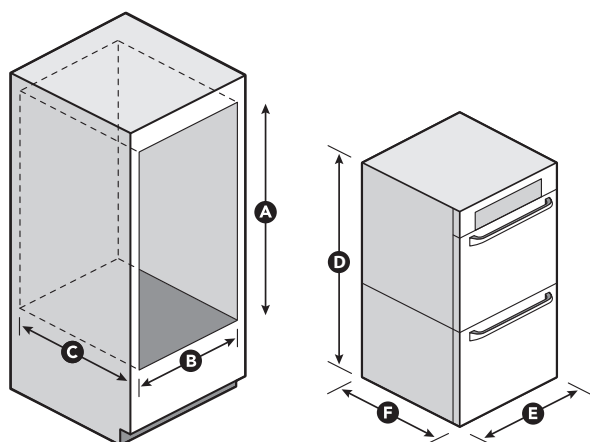

DIMENSIONS ARE SHOWN FOR PLANNING PURPOSES ONLY.
For complete information, see Installation Instructions packed with product.

Combination Microwave Wall Ovens

SPECIFICATIONS AND DIMENSIONS

	WHIRLPOOL®	WHIRLPOOL GOLD®
MODEL	WOC54EC0A	WOC95EC0A
Size	30"	30"
Also available in 27"	WOC54EC7A	
Upper microwave oven capacity (cu. ft.)	1.4	1.4
Lower oven capacity (cu. ft.)	5.0 / 4.3	5.0
Recommended cooktops	W5CE3024X W5CG3024X	G9CE3074X G7CG3064X
Metal handles	.	.
Designed, engineered and assembled in the U.S.A.	.	.
UPPER MICROWAVE OVEN FEATURES		
Sensor microwave with drop-down door	.	.
Steam cooking	8205262RB	8205262RB
Power (watts)	900	900
Stainless steel interior	.	.
Turntable diameter	14 1/8"	14 1/8"
OVEN FEATURES		
AccuBake® temperature management system	.	.
Precise Clean™ self-cleaning system	.	.
SteamClean option	.	.
Hidden bake element	.	.
TimeSavor™ Ultra true convection	.	◆
Convection Conversion	.	◆
Rapid Preheat	.	◆
Preheat countdown	Temperature	Temperature
Delay Bake	.	.
Hold Warm	.	.
Custom Broil	.	.
Closed door broiling	.	.
Sabbath Mode	.	.
Control lock	.	.
Illuminated display (two-color)	.	.
Oven lights	Incandescent	Incandescent
Total adjustable racks	2	3
EasyView™ extra-large oven window	.	.
GENERAL INFORMATION		
Bake element watts at 240/208 volts	2800W/2427W	2800W/2427W
Broil element watts at 240/208 volts	3600W/3120W	3600W/3120W
Convection element watts at 240/208 volts		2500W/2167W
Circuit amperage	40 Amps	40 Amps
Total connected load at 240 volts	5.5 kW	5.5 kW
Total connected load at 208 volts	4.6 kW	4.6 kW
27" Oven cavity size (H x W x D)	18" x 22" x 19"	
30" Oven cavity size (H x W x D)	18" x 25" x 19"	18" x 25" x 19"
DIMENSIONS AND COLORS		
Cutout height (A)	41"-41 1/2"	41"-41 1/2"
Cutout width (B)	28 1/2" / 25 1/2"	28 1/2"
Cutout depth (C)	24"	24"
Overall height (D)	42 3/16"	42 3/16"
Overall width (E)	30" / 27"	30"
Overall depth (F)	26 3/8"	26 3/8"
Available colors	W B S	B S H E

Bold type indicates a step-up feature

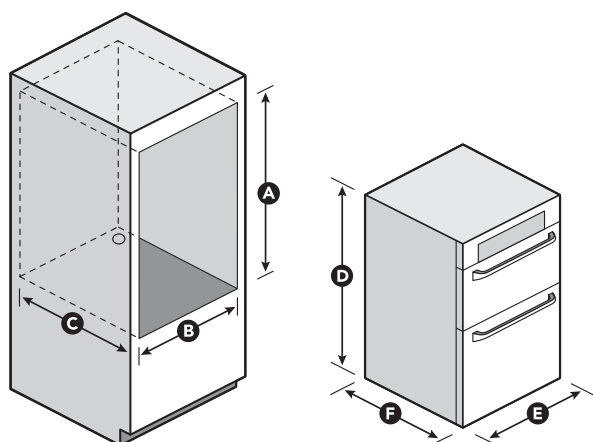

DIMENSIONS ARE SHOWN FOR PLANNING PURPOSES ONLY.
For complete information, see Installation Instructions packed with product.

Electric Cooktops

SPECIFICATIONS AND DIMENSIONS

MODEL	WHIRLPOOL®			WHIRLPOOL GOLD®	
	RCS2012R	WCC31430A	W5CE3024X	G7CE3034X	G7CE3055X
	21" Coil	30" Coil	30" Ceramic glass	30" Ceramic glass	30" Ceramic glass
Recommended wall oven	WOS51EC0/7A WOD51EC0/7A WOC54EC0/7A	WOS51EC0/7A WOD51EC0/7A WOC54EC0/7A	WOS51EC0/7A WOD51EC0/7A WOC54EC0/7A	WOS92EC0/7A WOD93EC0/7A WOC95EC0A	WOS92EC0/7A WOD93EC0/7A WOC95EC0A
Volts/Circuit Amps or VAC required	240/20	240/40	240/30	240/40	240/40
Designed, engineered and assembled in the U.S.A.
PERFORMANCE FEATURES					
Element type	High-speed coil	High-speed coil	Radiant	Radiant	Radiant
Left rear element		8" 2,350-watt	7" 1,800-watt	10" 2,500-watt	6" 1,200-watt
Right rear element		6" 1,500-watt	6" 1,200-watt	6" 1,200-watt	6" 100-watt Warm Zone
Left front element	6" 1,250/900-watt	6" 1,500-watt	6" 1,200-watt	6" 1,200-watt	10" 2,500-watt
Right front element	8" 2,100/1,575-watt	8" 2,350-watt	9" 2,500-watt	12" 3,000/1,900-watt AccuSimmer® dual	10" 2,500-watt AccuSimmer® dual
Center rear element					6" 1,200-watt
Simmer function			♦	.	.
Chrome drip bowls	.	No Drip			
CONVENIENCE FEATURES					
Controls	Knobs	Knobs	Knobs	Stainless steel finish knobs*	Stainless steel finish knobs*
Dishwasher-safe control knobs		♦	.	.	.
Cooktop surface	Stainless steel	Porcelain SpillGuard™	Eco-friendly ceramic glass**	Eco-friendly ceramic glass**	Eco-friendly ceramic glass**
Infinite heat controls
Hot surface indicator lights			♦	.	.
Power "On" light
Compatible above wall oven		♦	.	.	.
DIMENSIONS AND COLORS					
Cutout width (A)	18 5/8"	28 3/8"	29 1/2"	29 1/2"	29 1/2"
Cutout depth (B)	15 1/2"	19 5/8"	20 1/2"	20 1/2"	20 1/2"
Height (C)	2 1/8"	3 1/4"	3 3/4"	3 3/4"	3 3/4"
Width (D)	21"	30"	30 3/8"	30 3/8"	30 3/8"
Depth (E)	16 1/2"	21"	21 1/4"	21 1/4"	21 1/4"
Available colors	S	W B R	W B S	P B C S	B S

♦ Bold type indicates a step-up feature

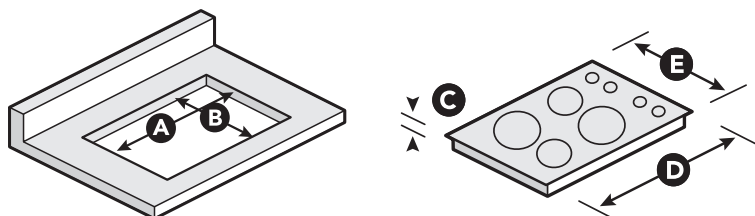

*Stainless Steel models only. **Glass cooktop surface manufactured without the release of hazardous metals into the earth.

DIMENSIONS ARE SHOWN FOR PLANNING PURPOSES ONLY.
For complete information, see Installation Instructions packed with product.

Electric Cooktops

SPECIFICATIONS AND DIMENSIONS

MODEL	WHIRLPOOL GOLD*			WHIRLPOOL*	WHIRLPOOL GOLD*	
	G9CE3065X	G9CE3074X	GCI3061X	W5CE3625A	G7CE3635X	G9CE3675X
	30" Ceramic glass	30" Ceramic glass	30" Induction	36" Ceramic glass	36" Ceramic glass	36" Ceramic glass
Recommended wall oven	WOS92EC0/7A WOD93EC0/7A WOC95EC0A	WOS92EC0/7A WOD93EC0/7A WOC95EC0A	WOS92EC0/7A WOD93EC0/7A WOC95EC0A	WOS92EC0/7A WOD93EC0/7A WOC95EC0A	WOS92EC0/7A WOD93EC0/7A WOC95EC0A	WOS92EC0/7A WOD93EC0/7A WOC95EC0A
ADA compliant†	♦	♦
Volts/Circuit Amps or VAC required	240/30	240/40	240/40	240/40	240/40	240/40
Designed, engineered and assembled in the U.S.A.	.	.	.	♦	.	.
PERFORMANCE FEATURES						
AccuHeat™ induction technology	♦					
Element type	AccuSimmer® Plus radiant	AccuSimmer® Plus radiant	Induction	Radiant	Radiant	AccuSimmer® Plus radiant
Left rear element	9" 2,200-watt	10"/6" 2,500/1,200-watt dual	9" 2,300/3,200-watt Boost	10" 2,500-watt	10"/6" 2,500/1,200-watt dual	10"/6" 2,500/1,200-watt dual
Right rear element	10"/6" 2,500/1,200-watt dual	12"/9"/6" 3,000/1,950/ 1,050-watt triple	8" 2,300-watt	10"/6" 2,500/1,200-watt dual	12"/9" 3,000/1,900-watt AccuSimmer® dual	12"/9"/6" 3,000/1,950/ 1,050-watt triple
Left front element	6" 1,200-watt	6" 1,200-watt	6" 1,400-watt	6" 1,200-watt	6" 1,200-watt	6" 1,200-watt
Right front element	6" 1,200-watt	6" 1,200-watt	6" 1,400-watt	6" 1,200-watt	6" 1,200-watt	6" 1,200-watt
Center rear element	6" 100-watt Warm Zone			6" 100-watt Warm Zone	6" 100-watt Warm Zone	6" 1,200-watt
Boost function			♦			
Simmer function
CONVENIENCE FEATURES						
Controls	Tap Touch	Tap Touch	Tap Touch	Knobs	Stainless steel finish knobs	Tap Touch
Dishwasher-safe control knobs				.	.	
Ceramic glass cooktop	Eco-friendly**	Eco-friendly**	.	Eco-friendly**	Eco-friendly**	Eco-friendly**
Infinite heat controls				.	.	
Hot surface indicator lights
Power "On" light
Automatic pan detection			♦			
Timer			♦			
Control lock	♦	.	.			♦
Compatible above wall oven	♦	.
DIMENSIONS AND COLORS						
Cutout width (A)	29½"	29½"	29½"	35½"	35½"	35½"
Cutout depth (B)	20½"	20½"	19½"	20½"	20½"	20½"
Height (C)	¾"	¾"	¾"	¾"	¾"	¾"
Width (D)	30⅞"	30⅞"	30⅞"	36⅝"	36⅝"	36⅝"
Depth (E)	21¼"	21¼"	21¼"	21¼"	21¼"	21¼"
Available colors	B S	B	B	B	B S	B S

Bold type indicates a step-up feature

*Stainless Steel models only. **Glass cooktop surface manufactured without the release of hazardous metals into the earth.
†Meets ADA push/pull force and reach guidelines.

DIMENSIONS ARE SHOWN FOR PLANNING PURPOSES ONLY.
For complete information, see Installation Instructions packed with product.

Gas Cooktops

SPECIFICATIONS AND DIMENSIONS

MODEL	WHIRLPOOL®		WHIRLPOOL GOLD®		WHIRLPOOL®	WHIRLPOOL GOLD®		
	W3CG3014X	W5CG3024X	GLT3057R	G7CG3064X	W5CG3625X	GLT3657R	G7CG3665X	GLS3665R
	30" Porcelain or stainless steel	30" Porcelain or stainless steel	30" Tempered glass	30" Stainless steel	36" Porcelain or stainless steel	36" Tempered glass	36" Stainless steel	36" Stainless steel
Recommended wall oven	WOS51EC0/7A WOD51EC0/7A WOC54EC0/7A	WOS51EC0/7A WOD51EC0/7A WOC54EC0/7A	WOS92EC0/7A WOD93EC0/7A WOC95EC0A	WOS92EC0/7A WOD93EC0/7A WOC95EC0A	WOS51EC0/7A WOD51EC0/7A WOC54EC0/7A	WOS92EC0/7A WOD93EC0/7A WOC95EC0A	WOS92EC0/7A WOD93EC0/7A WOC95EC0A	WOS92EC0/7A WOD93EC0/7A WOC95EC0A
ADA compliant*	.	.	.	♦	.	.	♦	.
Volts/Amps required	120/15	120/15	120/15	120/15	120/15	120/15	120/15	120/15
Designed, engineered and assembled in the U.S.A.
PERFORMANCE FEATURES								
Left rear burner	9,100 BTU	12,500 BTU Power™	9,100 BTU	9,200 BTU	9,200 BTU	6,000 BTU AccuSimmer®	5,000 BTU AccuSimmer®	9,000 BTU
Right rear burner	9,100 BTU	9,200 BTU	6,000 BTU AccuSimmer®	15,000 BTU Power™	9,200 BTU	6,000 BTU AccuSimmer®	12,500 BTU Power™	12,000 BTU Power™
Left front burner	10,500 BTU	5,000 BTU AccuSimmer®	12,500 BTU Power™	17,000 BTU Power™	9,200 BTU	12,500 BTU Power™	17,000 BTU Flex Power™	12,000 BTU Power™
Right front burner	5,000 BTU AccuSimmer®	12,500 BTU Power™	12,500 BTU Power™	5,000 BTU AccuSimmer®	12,500 BTU Power™	12,500 BTU Power™	5,000 BTU AccuSimmer®	9,000 BTU
Center rear burner					5,000 BTU AccuSimmer®	9,100 BTU	9,000 BTU Oval	
Center burner								15,000 BTU Power™
CONVENIENCE FEATURES								
Control knobs	.	Dishwasher safe	Dishwasher safe	Dishwasher safe	Dishwasher safe	Dishwasher safe	Dishwasher safe	.
Stainless steel finish control knobs				♦			♦	.
Recessed grate design								♦
Dishwasher-safe grates	Enamel steel	Full-width, cast-iron	Full-width, cast-iron	Full-width, cast-iron	Full-width, cast-iron	Full-width, cast-iron	Full-width, cast-iron	Full-width, cast-iron
Sealed burners
Infinite heat controls
Included LP conversion kit
Compatible above wall oven
DIMENSIONS AND COLORS								
Cutout width (A)	29"	29"	29"	29"	35¼"	35¼"	35¼"	35⅜"
Cutout depth (B)	19"	19"	19"	19"	19"	19"	19"	19½"
Height (C)	2⅞"	3 ² / ₃₂ "	2⅞"	3½"	3⅞"	2⅞"	3½"	2 ²⁷ / ₃₂ "
Width (D)	31 ⁷ / ₁₆ "	29½"	30 ⁵ / ₁₆ "	31 ⁷ / ₁₆ "	36"	36 ⁵ / ₁₆ "	37 ¹⁹ / ₃₂ "	36"
Depth (E)	21¼"	21½"	21¼"	21"	21"	21¼"	20 ¹⁵ / ₁₆ "	20⅞"
Available colors	W B S	W B S	B	S	B S	B	S	S

Bold type indicates a step-up feature

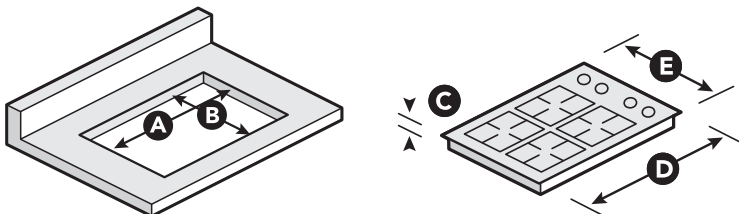

*Meets ADA push/pull force and reach range guidelines.

DIMENSIONS ARE SHOWN FOR PLANNING PURPOSES ONLY.
For complete information, see Installation Instructions packed with product.

Modular Cooktop

SPECIFICATIONS AND DIMENSIONS

		WHIRLPOOL®
MODEL	SC8720ED	
30" Modular Downdraft Gas Cooktop		
Recommended wall oven	WOS51EC0/7A WOD51EC0/7A WOC54EC0/7A	
Designed, engineered and assembled in the U.S.A.		
FEATURES		
Downdraft vent	•	
10,000-BTU fixed burners	2	
Optional modules available	3**	
Infinite heat controls	•	
Dishwasher-safe control knobs	Lift off	
Dishwasher-safe, full-width, cast-iron, matte-finish grates	•	
Sealed burners	•	
Removable/washable vent filter	•	
Included LP conversion kit	•	
DIMENSIONS AND COLORS		
Cutout width (A)	28 ⁷ / ₈ "	
Cutout depth (B)	20 ¹⁵ / ₁₆ "	
Height (C)	4"–16"	
Width (D)	29 ⁷ / ₈ "	
Depth (E)	21 ¹ / ₂ "	
Available colors	B	

		WHIRLPOOL®		
MODEL	SCM10D	SCM20D	SCM40D	
	30" Module	30" Module	30" Module	
FEATURES				
Surface burner module	•	•	•	
Non-stick grill module	•	•	•	
Grill cover	•	SCM50D	•	
Non-stick griddle module	•	•	•	
Grill module element required as a power source	•	•	SCM20D	
DIMENSIONS AND COLORS				
Available colors	B	B	B	

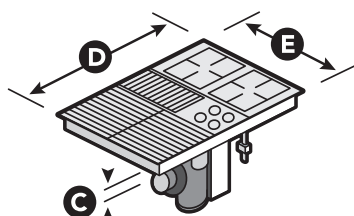
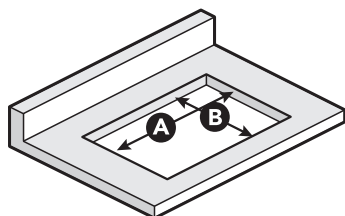

**Cooktop is shipped with one open bay and two fixed burners in the right bay. Select from the module options to complete your cooktop. Nonstick grill, surface burner and non-stick griddle modules available.

DIMENSIONS ARE SHOWN FOR PLANNING PURPOSES ONLY.
For complete information, see Installation Instructions packed with product.

Microwave Hood Combinations

SPECIFICATIONS AND DIMENSIONS

MODEL	WHIRLPOOL®			WHIRLPOOL GOLD®		
	WMH31017A	WMH32517A	WMH53520A	WMH75520A	WMH76718A	GH7208XR
Capacity (cu. ft.)	1.7	1.7	2.0	2.0	1.8	2.0
Stainless steel finish handle*	-	-	-	-	-	-
COOKING SYSTEM						
Sensor cooking	-	◆	-	-	-	-
Power (watts)	1,000	1,000	1,000	1,100	1,100	1,200
Grill watts	-	-	-	-	-	1,500
Velos® SpeedCook oven	-	-	-	-	-	◆
AccuWave® power system	-	-	-	◆	-	◆
TimeSaver™ Plus true convection	-	-	-	-	◆	-
10 Variable power levels	-	-	-	-	-	-
SpeedCook technology with grilling	-	-	-	-	-	◆
Steam cooking	-	◆	-	-	-	-
Staged cooking	-	-	-	-	-	-
VENTILATION SYSTEM						
Auto Adapt fan	-	-	◆	-	-	-
Convertible ventilation system	2-speed, 220 CFM fan	3-speed, 300 CFM fan	4-speed, 400 CFM fan	4-speed, 300 CFM fan	4-speed, 300 CFM fan	4-speed, TruCapture® 300 CFM fan
Hidden vent	-	-	-	-	-	-
Filter change indicator	-	-	-	-	-	-
CYCLES						
Broil function	-	-	-	-	-	◆
Convection Bake and Roast	-	-	-	-	◆	-
AccuSimmer® cycle	-	◆	-	-	-	-
Auto Cook, Defrost, Reheat	-	-	-	-	-	-
Kids Menu	-	-	-	◆	-	-
Melt/Soften	-	-	-	-	-	-
Warm Hold	-	◆	-	-	-	-
CONVENIENCE FEATURES						
CleanRelease® non-stick interior	-	-	◆	-	-	-
Most Used cycle	-	-	-	-	-	◆
Touch screen controls	-	-	-	-	-	◆
Control lock	-	-	-	-	-	-
Add 30 seconds	-	-	-	-	-	-
Recessed glass turntable	-	Stoppable	Stoppable	Stoppable	Stoppable	Stoppable
Cooking rack	-	◆	-	-	Cooking and convection racks	Convection rack, grill rack and crisper pan
Timer display color	Blue	Blue	Blue	Blue	Blue	Touch screen
EZ-View™ lighting	-	-	-	-	-	Halogen lighting
Night-light setting	-	-	-	-	-	-
ACCESSORIES						
Microwave steamer	-	-	-	Optional	◆	-
Crisper pan with handle	-	-	-	-	-	◆
Grease filter part number	W10208631A	W10208631A	W10208631A	W10208631	W10208631	W10120839A
Charcoal filter part number	8206230A	8206230A	8206230A	8206230A	8206230A	W10120840A
DIMENSIONS AND COLORS						
Minimum cutout width (A)	30"	30"	30"	30"	30"	30"
Minimum install height (B)	66"	66"	66"	66"	66"	66"
Height (C)	17¼"	17¼"	17¼"	17¼"	17¼"	15¼"
Width (D)	29⅝"	29⅝"	29⅝"	29⅝"	29⅝"	29⅝"
Depth (E)	16¼"	16¼"	16¼"	16"	16"	18⅞"
Available colors	W B D S	W B T S	W B S H E	W B S	W B S	S

Bold type indicates a step-up feature

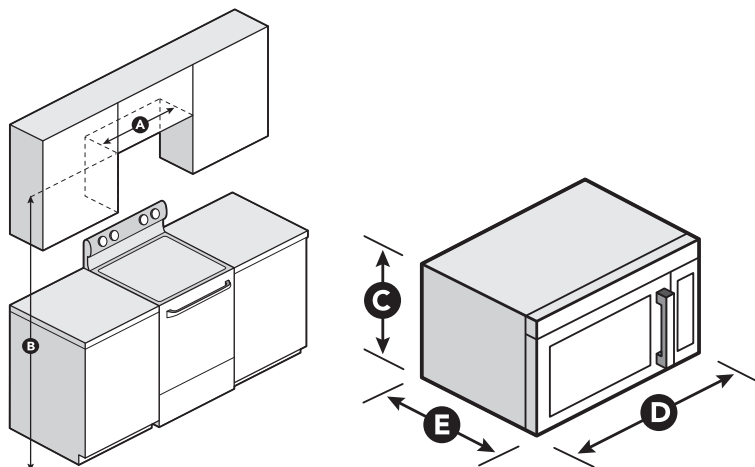

*Available on Stainless Steel, Monochromatic Stainless Steel, White Ice and Black Ice models only.

DIMENSIONS ARE SHOWN FOR PLANNING PURPOSES ONLY.
For complete information, see Installation Instructions packed with product.

Countertop Microwaves

SPECIFICATIONS AND DIMENSIONS

MODEL	WHIRLPOOL®					
	WMC10007A	WMC10511A	WMC11511A	WMC30516A	WMC20005Y	WMC50522A
New 2013 model						
Capacity (cu. ft.)	0.7	1.1	1.1	1.6	0.5	2.2
COOKING SYSTEM						
Sensor cooking		♦	•	•		♦
Power (watts)	700	1,000	1,000	1,200	750	1,200
10 Variable power levels	•	•	•	•	•	•
Staged cooking		♦	•	•		
PROGRAMMED CYCLES AND SENSOR FUNCTIONS						
Soups/Sauces				Programmed		Programmed
Dinner Plate	Programmed	Sensor	Sensor	Sensor		Sensor
Pizza Reheat	Programmed	Programmed	Programmed	Programmed		Programmed
Beverage	Programmed	Programmed	Programmed	Programmed		Programmed
Frozen Entree	Programmed	Sensor	Sensor	Programmed		Programmed
Popcorn	Programmed	Programmed	Programmed	Programmed	Programmed	Programmed
Fresh Vegetables	Programmed					Sensor
Baked Potato	Programmed	Programmed	Programmed	Programmed		Programmed
CYCLES						
Manual Cook					♦	
Auto Defrost	•	•	•	•	•	•
Manual Reheat					♦	
CONVENIENCE FEATURES						
Electronic touch controls	•	•	•	•	Tap Touch	•
Time cook	•	•	•	•	•	•
Add-a-Minute option	•					♦
Add 30 seconds option		♦	•	•	•	•
Control lock	•	•	•	•	•	•
Rounded-back design					♦	
Turntable	•	Large glass	Large glass	Large glass	Glass	Large recessed glass
Microwave Built-in trim kit				Optional		Optional
Under counter mounting bracket	•					
DIMENSIONS AND COLORS						
Height (A)	13 ³ / ₁₆ "	12 ¹ / ₁₆ "	12 ¹ / ₁₆ "	13"	14 ¹ / ₈ "	12 ³ / ₁₆ "
Width (B)	17 ¹³ / ₁₆ "	20 ¹ / ₄ "	20 ¹ / ₄ "	21 ³ / ₄ "	15 ³ / ₈ "	24"
Depth (C)	10 ³ / ₁₆ "	16 ¹ / ₄ "	16 ¹ / ₈ "	17 ¹ / ₄ "	13 ³ / ₄ "	19 ⁵ / ₁₆ "
Available colors	W B	W B	S	W B S	W B D	W B S

Bold type indicates a step-up feature

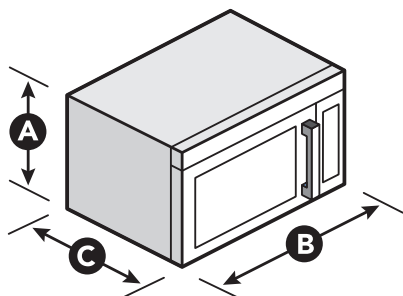

DIMENSIONS ARE SHOWN FOR PLANNING PURPOSES ONLY.
For complete information, see Installation Instructions packed with product.

Under Cabinet Hoods

SPECIFICATIONS AND DIMENSIONS

WHIRLPOOL GOLD®

MODEL	UXT2030AY	UXT3030AY	UXT4030AY	UXT4230AY	UXT5230AY	UXT5530AA	GXU7130DX
Also available in 36"	30" Traditional	30" Traditional	30" Traditional	30" Traditional	30" Traditional	30" High Performance	30" Traditional
Vertical venting	Exterior	Exterior	Interior	Exterior and Interior	Exterior and Interior	Exterior and Interior	Exterior
Horizontal venting	Exterior	Exterior	Interior	Exterior and Interior	Exterior and Interior	Exterior and Interior	Exterior
Type	Top venting only	Top and rear venting	Recirculating only	Convertible	Convertible	Convertible	Vented only
DUCT TYPE							
7" Round duct	Included			Included	W10355451		
3¼" x 10" Rectangular duct		Included		Included	Included	Included	Included
Dishwasher-safe grease filter	1	1		1	1	2 (30") or 3 (36")	2
FEATURES							
ENERGY STAR® qualified							♦
Maximum exhaust (CFM)*	190	190		225	350	400	300
Sones†	up to 4.5	up to 5.3		up to 7	up to 9	up to 8.2	up to 7.2 (.32 working speed)
Controls	2-speed, rocker switch	2-speed, rocker switch	2-speed, rocker switch	Variable speed, rotary	3-speed, push-button	3-speed, push-button	3-speed, push-button
Damper					♦		
Fan	Axial	Axial	Axial	Axial	Axial	Centrifugal	Centrifugal
Lighting	75-watt On/Off incandescent	75-watt On/Off incandescent	75-watt On/Off incandescent	75-watt High/Low/Off incandescent	50-watt High/Low halogen (bulbs included)	50-watt High/Low halogen (bulbs included)	On/Off fluorescent
Recirculation kit/Charcoal filter			Included	Optional	Optional	Included	
Power cord included						♦	
Damper/Vent connector included	7" Round	3¼" x 10" Rectangular		3¼" x 10" Rectangular	3¼" x 10" Rectangular	3¼" x 10" Rectangular	3¼" x 10" Rectangular
California Title 24 compliant	-	-	N/A	-	-	-	-
ACCESSORIES							
Recirculation kit/Charcoal filter kit			W10355450	W10355450	W10369358 / W10386873	W10272068	
7" Round damper				W10355451	W10355451		
7" Damper plate				W10388168	W10388168		
Power cord	W10355452	W10355452	W10355452	W10355452	W10355452		
DIMENSIONS AND COLORS							
Cutout width (A)	30"	30"	30" / 36"	30" / 36"	30" / 36"	30" / 36"	30"
Minimum mounted height (B)	18"	18"	18"	18"	18"	24"	24" (Electric) 27" (Gas)
Height (C)	5"	5"	5"	5"	5"	9"	4¾"
Width (D)	29 5/16"	29 5/16"	29 5/16" / 35 5/16"	29 5/16" / 35 5/16"	29 5/16" / 35 5/16"	29 5/16" / 35 5/16"	29 5/16"
Depth (E)	18 5/8"	18 5/8"	18 5/8"	18 5/8"	18 5/8"	19 1/10"	20"
Cutout depth	11 1/8"	11 1/8"	11 1/8"	11 1/8"	11 1/8"	12"	
Available colors	W B	W B	W B T† S†	W B T† S	W†† B†† S	S	S

Bold type indicates a step-up feature

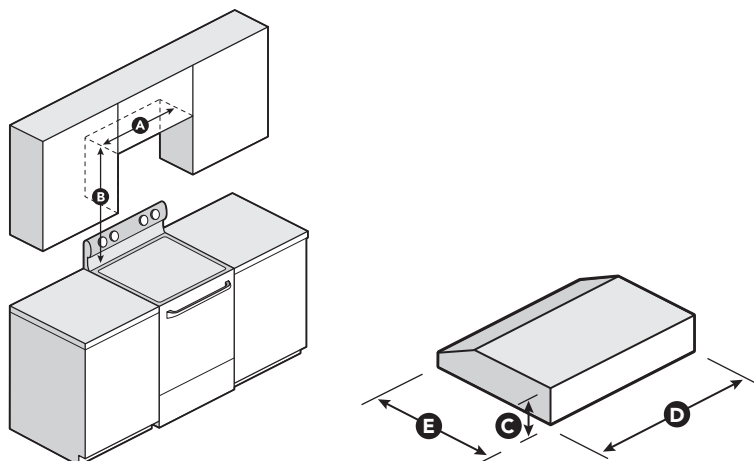

*Refer to Use & Care Guide for more information. **UXT4030AY only. †UXT4230AY only. ††UXT5230AY only.

DIMENSIONS ARE SHOWN FOR PLANNING PURPOSES ONLY.
For complete information, see Installation Instructions packed with product.

Canopy Hoods

SPECIFICATIONS AND DIMENSIONS

	WHIRLPOOL GOLD®		WHIRLPOOL GOLD®		WHIRLPOOL GOLD®		WHIRLPOOL GOLD®
MODEL	GXW6530DX	UXW6530BS	GXI6536DX	UXI6536BS	GXW7230DA	UXW7230BS	GXW7330DX
New 2013 model							
	30" Glass Wall-Mounted Canopy	30" Glass Wall-Mounted Canopy	36" Glass Island Canopy	36" Glass Island Canopy	30" Wall-Mounted Canopy	30" Wall-Mounted Canopy	30" Wall-Mounted Canopy
Also available in 36"	GXW6536DX	UXW6536BS					GXW7336DX
Vertical venting Type	Exterior and interior Convertible	Exterior and interior Convertible	Exterior and interior Convertible	Exterior and interior Convertible	Exterior and interior Convertible	Exterior and interior Convertible	Exterior and interior Convertible
DUCT TYPE							
Included 6" round duct	-	-	-	-	-	-	-
Dishwasher-safe grease filter	1	1	1	1	2	2	2
FEATURES							
ENERGY STAR® qualified							♦
Maximum exhaust (CFM)*	400	400	400	400	400	400	300
Sones*	up to 7.2	up to 7.2	up to 7.2	up to 7.2	up to 6.9 (2.4 working speed)	up to 6.9 (2.4 working speed)	up to 6 (1.4 working speed)
3-speed push-button controls	-	-	-	-	-	-	-
Damper	-	-	-	-	-	-	-
Centrifugal fan	-	-	-	-	-	-	-
Lighting (bulbs included)	On/Off incandescent	On/Off incandescent	On/Off halogen	On/Off halogen	On/Off incandescent	On/Off incandescent	On/Off fluorescent
Recirculation kit/Charcoal filter	Optional	Optional	Optional	Optional	Optional	Optional	Optional
Other accessories	Chimney extension kit	Chimney extension kit	Chimney extension kit	Chimney extension kit	Chimney extension kit	Chimney extension kit	Chimney extension kit
DIMENSIONS AND COLORS							
A	13 1/16"	13 1/16"	13 1/16"	13 1/16"	8 1/8"	8 1/8"	8 1/8" / 8 1/16"
B	10 7/8"	10 7/8"	12 1/4"	12 1/4"	7 1/4"	7 1/4"	7 1/4" / 7 1/8"
Recirculating height (C)	27 7/8"–45 1/2"	27 7/8"–45 1/2"	29 3/4"–49 5/16"	29 3/4"–49 5/16"	28 7/8"–42 1/16"	28 7/8"–42 1/16"	28 7/8"–42 1/16"
Vented height (C)	27 7/8"–41 1/8"	27 7/8"–41 1/8"	29 3/4"–44 5/16"	29 3/4"–44 5/16"	28 3/8"–38"	28 3/8"–38"	28 3/8"–38"
Width (D)	30" / 36"	30" / 36"	36"	36"	30"	30"	30" / 36"
Depth (E)	20"	20"	25 3/16"	25 3/16"	20"	20"	20"
Minimum mounted height (above cooking surface)	24" (Electric) 27" (Gas)	24" (Electric) 27" (Gas)	24" (Electric) 27" (Gas)	24" (Electric) 27" (Gas)	24" (Electric) 27" (Gas)	24" (Electric) 27" (Gas)	24" (Electric) 27" (Gas)
Available colors	S	S	S	S	S	S	S

Bold type indicates a step-up feature

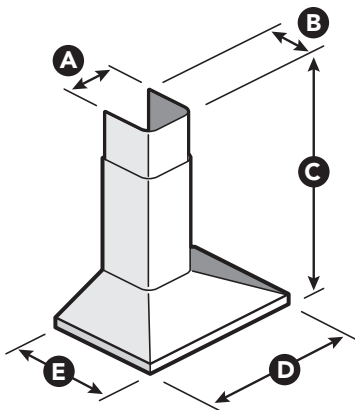

*Refer to Use & Care Guide for more information.

DIMENSIONS ARE SHOWN FOR PLANNING PURPOSES ONLY.
For complete information, see Installation Instructions packed with product.

Downdraft Vent

SPECIFICATIONS AND DIMENSIONS

MODEL	UXD8630DY
	30" Pop-Up Downdraft
Also available in 36"	UXD8636DY
Vertical venting	Exterior
Horizontal venting	Exterior
Type	Vented only
DUCT TYPE	
6" Round duct	Included
3¼" x 10" Rectangular duct	Included
Dishwasher-safe grease filter	2
FEATURES	
Maximum exhaust (CFM)*	600
Sones*	up to 7.9
Controls	4-speed slider
Damper	-
Fan	Dual centrifugal
Damper/Vent connector included	3¼" x 10" Rectangular
DIMENSIONS AND COLORS	
A	10"
B	13 ⅞"
C	16 ½"
D	27" / 33"
E	2 ⅞"
F	28 ½"
G	30" / 36"
Available colors	S

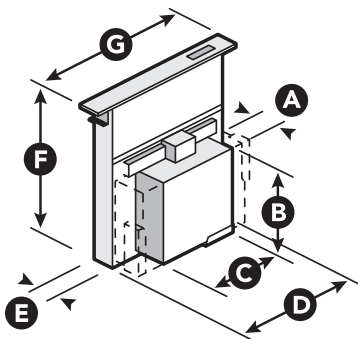

*Refer to Use & Care Guide for more information.

DIMENSIONS ARE SHOWN FOR PLANNING PURPOSES ONLY.
For complete information, see Installation Instructions packed with product.

Hood Liners

SPECIFICATIONS AND DIMENSIONS

MODEL	UXL5430BS	UXL6036YS	UXL6048YS
Vertical venting	30"	36" Under Cabinet	48" Under Cabinet
Type	Convertible	Vented	Vented
DUCT TYPE			
10" Round duct		♦	•
6" Round duct	•		
FEATURES			
Auto-On Heat sensor		♦	•
Controls	3-speed, push button	3-speed, slider	3-speed, slider
Lighting	2, 50-watt On/Off halogen (bulbs included)	4 , 50-watt High/Low halogen (bulbs included)	4, 50-watt High/Low halogen (bulbs included)
Dishwasher-safe grease filter	2	3	4
ACCESSORIES			
Blower motor systems	Included 400 CFM	Internal 600 CFM - UXB0600DYS Internal 1200 CFM - UXB1200DYS In-Line 600 CFM - UXI0600DYS In-Line 1200 CFM - UXI1200DYS	Internal 600 CFM - UXB0600DYS Internal 1200 CFM - UXB1200DYS In-Line 600 CFM - UXI0600DYS In-Line 1200 CFM - UXI1200DYS
Recirculation/Charcoal filter kit	W10490330	N/A	N/A
Face panel rear extension (30" x 18")	W10490327	N/A	N/A
Face panel (36" x 18")	W10490310	N/A	N/A
DIMENSIONS AND COLORS			
Height	13 ⁵ / ₈ "	11 ¹ / ₂ "	11 ¹ / ₂ "
Width	30"	35 ⁷ / ₈ "	47 ⁷ / ₈ "
Depth	11 ¹ / ₄ "	22"	22"
Available colors	S	S	S

Bold type indicates a step-up feature





DISHWASHERS

- 160 Built-in dishwashers
- 166 Compact dishwasher
- 167 Portable dishwasher
- 168 Food disposers
- 170 Trash compactors
- 172 Accessories
- 174 Glossary
- 176 Specifications



Whirlpool

DISHWASHERS



Takes the guesswork out of doing dishes

The Sensor cycle automatically selects the right wash and dry settings using two sensors that measure temperature, soil level and load size. It cleans tough soils 35% better* using the right amount of time, energy and water.



Makes washing large items easy

With features like the EZ-2-Lift™ adjustable upper rack and EZ Adjustable tines, you'll be able to take advantage of the large 15 place-setting capacity available on select Whirlpool® dishwashers.



Cleans without soaking or scrubbing

The enhanced PowerScour™ option uses 40 targeted spray jets in a designated wash area to scour away baked-on foods and deliver twice the coverage to clean your large pots and pans.



Uses less water and energy without compromising performance**

Not only do Whirlpool brand dishwashers use less water and energy to meet the CEE Tier 1† standard, but no one has fewer repairs 17 years in a row.†† Using our innovative resource-efficient wash system, these ENERGY STAR® qualified models will even save money on utility bills.

NOTE: Not all features are available on all models.

*Compared to previous wash system. **Compared to a conventional dishwasher manufactured before 2006. †Based on the Consortium for Energy Efficiency qualifying product lists. Visit cee1.org for more information. ††According to a leading consumer magazine.

Dishwashers



WDF310PAA W | B | T | D | S

ENERGY STAR® qualified
Meets CEE Tier 1* standards
In-the-Rack silverware basket
Resource-efficient wash system
Quiet Partner™ I sound package
6" Console with electronic controls
White plastic tall tub



WDF510PAY W | B | D | S

AnyWare™ Plus silverware basket
Quiet Partner™ II sound package
4" Console with electronic controls
ENERGY STAR® qualified
Meets CEE Tier 1* standards
Resource-efficient wash system
White plastic tall tub

*Based on the Consortium for Energy Efficiency qualifying product lists. Visit cee1.org for more information.

Step-up features
highlighted by
yellow bar



Most Whirlpool® dishwashers
are ENERGY STAR® qualified.

Dishwashers



WDF530PAY W | B | T | M

2½" Sleek console with electronic controls

Slate plastic tall tub

ENERGY STAR® qualified

Meets CEE Tier 1* standards

AnyWare™ Plus silverware basket

Resource-efficient wash system

Quiet Partner™ II sound package



WDF550SAA W | B | S

Stainless steel tall tub

ADA height and reach compliant**

ENERGY STAR® qualified

Meets CEE Tier 1* standards

In-the-Rack silverware basket

Resource-efficient wash system

Quiet Partner™ I sound package

5" Console with electronic controls

*Based on the Consortium for Energy Efficiency qualifying product lists. Visit cee1.org for more information. **Meets ADA height and reach requirements and must be installed in compliance with ADA Standards.

Feature descriptions can be found in the glossary on pages 174–175. Complete product specifications can be found on page 176.

Dishwashers



WDT710PAY W | B | M | H | E

- Whirlpool Gold® model
- Sensor cycle
- AnyWare™ Plus silverware basket
- Adjustable upper rack
- Quiet Partner™ II sound package
- Fully integrated electronic controls
- ENERGY STAR® qualified
- Meets CEE Tier 1* standards
- Resource-efficient wash system
- Slate plastic tall tub



WDF750SAY W | B | M

- Whirlpool Gold® model
- Quiet Partner™ IV sound package
- Stainless steel tall tub
- Sensor cycle
- ENERGY STAR® qualified
- Meets CEE Tier 1* standards
- AnyWare™ Plus silverware basket
- Resource-efficient wash system
- 2½" Sleek console with electronic controls



*Based on the Consortium for Energy Efficiency qualifying product lists. Visit cee1.org for more information.

Step-up features highlighted by yellow bar



Most Whirlpool® dishwashers are ENERGY STAR® qualified.

Dishwashers



WDT790SAY W | B | M

Whirlpool Gold® model

Adjustable upper rack

Fully integrated electronic controls

Sensor cycle

ENERGY STAR® qualified

Meets CEE Tier 1* standards

AnyWare™ Plus silverware basket

Resource-efficient wash system

Quiet Partner™ IV sound package

Stainless steel tall tub



WDT910SAY M | H | E

Whirlpool Gold® model

PowerScour™ option

EZ Adjustable tines

EZ-2-Lift™ adjustable upper rack

Sensor cycle

ENERGY STAR® qualified

Meets CEE Tier 1* standards

AnyWare™ Plus silverware basket

Resource-efficient wash system

Quiet Partner™ IV sound package

Fully integrated electronic controls

Stainless steel tall tub

*Based on the Consortium for Energy Efficiency qualifying product lists. Visit cee1.org for more information.

Feature descriptions can be found in the glossary on pages 174–175. Complete product specifications can be found on page 177.

Compact Dishwasher



WDF518SAA W | B | M

- ENERGY STAR® qualified
- In-the-Rack silverware basket
- Resource-efficient wash system
- Quiet Partner™ I sound package
- 5" Console with electronic controls
- Stainless steel tall tub



Most Whirlpool® dishwashers
are ENERGY STAR® qualified.

Portable Dishwasher



WDP350PAA W | B

ENERGY STAR® qualified
In-the-Rack silverware basket
Resource-efficient wash system
Quiet Partner™ I sound package
Electronic controls
White plastic tall tub

Feature descriptions can be found in the glossary on pages 174–175. Complete product specifications can be found on pages 178–179.

Food Disposers



GC1000XE/PE*

- 1/3-HP motor
- Locked-in mounting
- Continuous-feed operation
- Overload protector
- Manual reset



GC2000XE/PE*

- 1/2-HP motor**
- Locked-in mounting
- Continuous-feed operation
- Overload protector
- Manual reset

*Also available with plug and cord.

Step-up features
highlighted by
yellow bar

Food Disposers



GC5000XE

- ¾-HP motor
- Stainless steel grinding wheel
- Sound insulation
- Locked-in mounting
- Continuous-feed operation
- Overload protector
- Manual reset

Feature descriptions can be found in the glossary on pages 174–175. Complete product specifications can be found on page 180.

Trash Compactors



GX900QPP 1.4 cu. ft. Q | B | S

Whirlpool Gold® model
1/3-HP motor
Touch pad controls
Clean Touch™ console
Under counter
Touch-Toe™ drawer opener
Easy Rollers™ installation wheels
Tilt-Away trash basket

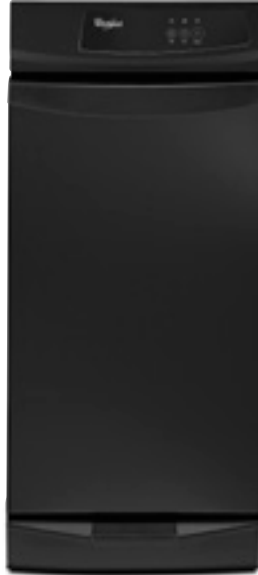

GC900QPP 1.4 cu. ft. Q | B

Whirlpool Gold® model
Convertible freestanding-to-built-in
1/3-HP motor
Touch pad controls
Clean Touch™ console
Touch-Toe™ drawer opener
Easy Rollers™ installation wheels
Tilt-Away trash basket

Step-up features
highlighted by
yellow bar

Trash Compactors



TU950QPX 1.4 cu. ft. S

Fully integrated controls

Under counter

1/3-HP motor

Touch-Toe™ drawer opener

Easy Rollers™ installation wheels

Feature descriptions can be found in the glossary on pages 174–175. Complete product specifications can be found on page 181.

Accessories



Small Items Basket (3370993RB)

Fits all Whirlpool® dishwashers. It holds baby items, jar lids and other small utensils that would normally slip through the dishwasher rack.



Swivel Gooseneck Fitting (W10574777)

Space-saving 90° design makes this 3/4" x 3/8" elbow hose fitting perfect for easy dishwasher installation. A 3/8" brass compression fitting is included. Required on dishwashers produced after 2009.



12' Drain Hose (Tall Tub-3385556) 12' Drain Hose (NEW-8531858) 6' Drain Hose (8269144A)

This flexible drain hose for tall tub dishwasher models offers a no-kink design made for hot water.



Small Items Bag (8519716)

Holds extra-small utensils, contact cases and other small items that would normally slip through the dishwasher rack.



6', 3-Prong Dishwasher Power Supply Kit (W10278923RP)

This straight, 6', 90° UL-listed power cord kit fits dishwashers from most major brands and includes a power cord, metal strain relief bracket, wire nuts and instructions.



Undercounter Mounting Kit (W10426979)

Works with all standard size dishwashers. Can be used with solid surfaces, including granite.



NEW! affresh® Disposal cleaner (W10509526)

Foaming action works to loosen food and organic material to clean and deodorize. Carton contains 4 tablets.



affresh® Dishwasher Cleaner (W10282479)

Powers away hard water mineral residue and is Designed for the Environment.* Pouch contains 6 tablets.



Dishwasher Rack Repair Kit White: 4396838RC Black: 4396839RC Grey: 4396840RC

This kit has everything you need to repair your dishwasher rack tines. It contains 150 tine tips, a 4-oz bottle of vinyl touch-up paint/adhesive with a brush and instruction sheet.

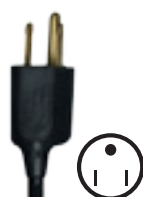

5', 3-Prong Dishwasher Power Cord (4317824)

Take home everything you need to bring power to your dishwasher with the UL-listed power cord, strain relief, wire nuts and installation instructions.

To acquire pricing information, order Whirlpool® dishwasher accessories and determine delivery time, visit whirlpool.com/accessories or call 1-800-462-3819.

*Visit epa.gov/dfe for more information.

Accessories

Mounting Kits

MODEL	WDF310PAA	WDF510PAY	WDF530PAY	WDT710PAY
Side mounting kit (plastic tubs only)	8212560	8212560	8212560	8212560
Tall tub floor mounting kit	4378968	4378968	4378968	4378968

MODEL	WDF750SAY	WDT790SAY	WDT910SAY
Floor mounting kit	8171477**	8171477**	8171477**
Side mounting kit	Not required	Not required	Not required

Hoses and Cords

Reinforced hoses include one of each of the following: 3/8" brass elbow, 3/8" brass compression fitting and 3/8" brass swivel gooseneck fitting.

AVAILABLE ACCESSORY	
4' Red EPDM hose	W10278625RP
5' Red EPDM hose	W10278626RP
6' Red EPDM hose (retail polybag)	W10278627RP
6' Braided hose (without teflon tape)	W10278635RP
6' Red EPDM hose (retail claim)	W10278627RC
6' Braided hose (with teflon tape)	W10278636RC
6' 3-prong dishwasher power supply kit	W10278923RP

Dishwasher Panels and Optional Accessory Kits

MODEL	WDF510PAY
4" Console trim kit†	White - 4396200 Black - 4396199 Biscuit - 4396201
Side panel kit	White - 8171656 Black - 8171657 Biscuit - 8171658 Stainless Steel - 8171659

**Stainless steel tall tub models only. †Trim Kit accommodates both a framed and frameless custom panel design. 6" custom panels for models WDF310PAA and WDF350PAA are not available at this time.

Glossary

1-Hour Wash cycle

Thoroughly cleans your dishes in nearly half the time.* This hour-long cycle helps you take care of dirty dishes when you are in a rush.

ADA height and reach compliant

Select dishwashers with this designation meet ADA height and reach requirements and must be installed in compliance with Americans with Disabilities Act Standards.

Adjustable upper rack

Manually raise or lower the upper rack to better fit tall items.

AnyWare™ Plus silverware basket

Designed to clean better and fit in four places for maximum flexibility, the AnyWare™ Plus silverware basket rests on two locations in the bottom rack, the front of the lower rack or in the door for 100% usable rack space.

Auto soil sensor

Optimizes every cycle for reliable cleaning results. This sensor measures water clarity to determine how dirty dishes are, then adjusts the cycle accordingly. It measures the soils in the water and will add extra water and adapt temperature to ensure clean dishes.

CEE Tier standards

Based on the Consortium for Energy Efficiency (CEE) qualifying product lists—with the Tier 1 standard being the most efficient. Visit cee1.org for more information.

Clean & Quiet Guarantee

If you are not completely satisfied that your new Whirlpool Gold® dishwasher is quieter and cleans better than your previous model, Whirlpool Corporation will take it back within 30 days of the date of purchase and refund the full price to you. Visit whirlpool.com for complete details and qualified models.

Clean Touch™ console

Select Whirlpool® trash compactors feature a smooth console with no dials or switches that cleans easily.

Control lock

Disables buttons on the control pad to help prevent accidental operation or children from starting or stopping the dishwasher.

Cup shelf

Allows you to stack two levels of coffee mugs or small cups and to secure delicate glassware when used as a stemware holder in the upper rack.

Delay Wash option

Wash dishes according to your schedule. This option lets you delay washing for up to 8 hours until off-peak hours when utility rates may be lower.

Easy Rollers™ installation wheels

Easily position your Whirlpool® compactor where you need it with the Easy Rollers™ installation wheels.

Eco Dry option

The industry's first Eco Dry option is the most efficient drying option on our dishwashers** because it uses 70% less energy compared to using Heated Dry.

Eco Wash cycle

Our most efficient dishwasher cycle helps minimize energy and water usage while cleaning dishes.** It is great for cleaning lightly to moderately soiled dishes.

ENERGY STAR® qualified

Exceeds government standards to help conserve natural resources and save money on utility bills.

EZ-2-Lift™ adjustable upper rack

Easily adjust the upper rack 2" up or down to fit larger items in either rack. Improved to allow for 100% usable upper rack space, our easiest to adjust rack can be lifted or lowered to accommodate different size items and features narrow profile adjusters that don't interfere with loading.

EZ Adjustable tines

Innovative sliding lower-rack tines move left or right to fit your dishes. Now you have twice the space between tines to fit larger bowls for optimal cleaning.

Fold-down tines

Secure dishes during the wash cycle or fold down to create space for larger items.

Fully integrated controls

Add a modern accent to your kitchen with a control panel that's hidden away and provides a sleek exterior while preventing unwanted cycle changes or accidental operation.

Heavy cycle

Adds more time to the cycle to clean heavily soiled items.

NOTE: Not all features are available on all models.

*Compared to Normal cycle with lightly soiled loads. **Available on Whirlpool® models MSRP \$449 and above.

Glossary

High Temperature Wash option

Choose this option when additional cleaning of items like baby bottles, glassware or dishes is required.

Light item clips

Secure lightweight items during the wash cycle and help prevent items from falling out of the rack. They also stop cups and other small containers from flipping over and filling with water.

Normal cycle

Use for loads with normal amounts of food soil. This cycle is great for everyday loads.

Nylon racks

Durable nylon coating helps resist rust and prevent scratching.

Overnight cycle

This industry-exclusive cycle quietly soaks your dishes with an extended prewash and then runs a tough soil wash to clean dirty dishes.

PowerScour™ option

The PowerScour™ option uses 40 targeted spray jets in a designated wash area to scour away baked-on foods without soaking or scrubbing. From casserole dishes to pots and pans, this option delivers twice the coverage to clean large items.

Quiet Partner™ sound packages

Whirlpool brand dishwashers offer many levels of sound-reducing insulation. The Quiet Partner™ IV sound package is the highest available.

Resource-efficient wash system

Efficiently cleans a full load of dishes using nearly half the water and energy.[†] This system provides excellent cleaning first in the upper rack, then the lower, to reduce the amount of water used.

Sani Rinse option

Sanitizes dishes by eliminating 99.999% of food soil and bacteria.

Sensor cycle

Automatically selects the right wash and dry settings for your load by using two separate sensors to measure temperature, soil level and load size once during the prewash and once during the wash cycle. It cleans tough soils 35% better^{††} using just the right amount of time, energy and water.

SheerClean™ wash system

Channels water up and out of the back and top of the dishwasher to powerfully clean from multiple angles. The filter keeps wash water clean and delivers sparkling-clean dishes.

Slate interior

Reduces the appearance of visible tub stains, wash after wash. Sophisticated slate styling gives the dishwasher an attractive, premium look.

Soak & Scour option

Gently soaks, powerfully cleans and then soaks again to remove tough soils from dishes so you don't have to.

Stainless steel interior

Retains heat from wash and rinse cycles to promote drying. The stainless steel interior also cools faster than the dishes, allowing moisture to condense on the interior walls and drawing additional water off the hotter dishes.

Tall tub design

Allows you to load tall and odd-shaped items in both racks. An additional 3" of interior space compared to standard tub models makes room for extra-large items in the lower rack and plates or sports bottles in the upper rack.

Top Rack Wash option

Save time and energy with the Top Rack Wash option. It washes the top rack of dishes, so you don't have to wait for a full load to wash a few items.

Touch-Toe™ drawer opener

Easily open Whirlpool® trash compactors without your hands using the Touch-Toe™ drawer opener. A light tap of the toe is all that's needed to release the drawer.

NOTE: Not all features are available on all models.

[†]Compared to dishwashers manufactured before 2006. ^{††}Compared to previous wash system.

Dishwashers

SPECIFICATIONS AND DIMENSIONS

WHIRLPOOL®				
MODEL	WDF310PAA	WDF510PAY	WDF530PAY	WDF550SAA
Place setting capacity	12	14	15	12
ENERGY STAR® qualified	•	•	•	•
Meets CEE Tier standards†	Tier 1	Tier 1	Tier 1	Tier 1
Tall tub design	•	•	•	•
Tub material	Plastic – White	Plastic – White	Plastic – Slate	Stainless steel
Sound package	Quiet Partner™ I (59 dBA**)	Quiet Partner™ II (55 dBA**)	Quiet Partner™ II (55 dBA**)	Quiet Partner™ I (54 dBA**)
ADA height and reach compliant†	•	•	•	♦
Designed, engineered and assembled in the U.S.A.	•	•	•	•
WASH SYSTEM				
Resource-efficient wash system	•	•	•	•
Auto soil sensor	•	•	•	•
Console height	6"	4"	2½"	5"
Electronic controls	•	•	•	•
5-level direct-feed	•	•	♦	•
4-level direct-feed	•	•	•	•
CYCLES				
Total number of cycles	3	5	5	5
Eco Wash	•	♦	•	•
Overnight	•	♦	•	•
1-Hour Wash	•	•	•	•
Pots & Pans	•	•	•	♦
Heavy	•	•	•	•
Normal	•	•	•	•
Light	•	•	•	♦
Rinse Only	•	•	•	♦
OPTIONS				
Total number of options	4	4	6	4
Eco Dry	•	•	♦	•
Heated Dry	•	•	•	•
Sani Rinse	•	♦	•	•
High Temperature Wash	•	•	•	•
Delay Wash	4 Hour	4 Hour	2-4-8 Hour	2-4-6 Hour
Control lock	•	•	♦	•
RACK FLEXIBILITY				
Rack coating	Vinyl	Vinyl	Nylon	Nylon
Light item clips	•	•	2	•
Cup shelves	•	•	♦	•
Silverware basket	In-the-Rack	AnyWare™ Plus	AnyWare™ Plus	In-the-Rack
DIMENSIONS AND COLORS				
Height (A)	33½"-34½"	33½"-34½"	33½"-34½"	32½"-34½"
Width (B)	23½"	23½"	23½"	24"
Depth (C)	24½"	24½"	24½"	24"
Minimum cutout height (D)	34"	34"	34"	34"
Cutout width (E)	24"	24"	24"	24"
Cutout depth (F)	24"	24"	24"	24"
Available colors	W B T D S	W B D S	W B T M	W B S

Bold type indicates a step-up feature

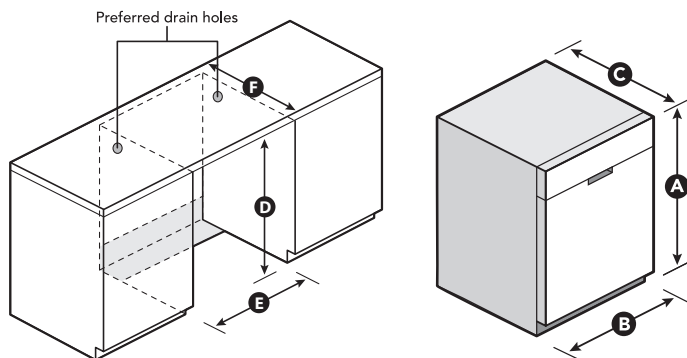

*Based on the Consortium for Energy Efficiency qualifying product lists. Visit cee1.org for more information.
 **Per IEC standards. †Meets ADA height and requirements and must be installed in compliance with ADA Standards.

DIMENSIONS ARE SHOWN FOR PLANNING PURPOSES ONLY.
 For complete information, see Installation Instructions packed with product.

Dishwashers

SPECIFICATIONS AND DIMENSIONS

	WHIRLPOOL GOLD®			
MODEL	WDT710PAY	WDF750SAY	WDT790SAY	WDT910SAY
Place setting capacity	15	15	15	15
ENERGY STAR® qualified	•	•	•	•
Meets CEE Tier standards*	Tier 1	Tier 1	Tier 1	Tier 1
Tall tub design	•	•	•	•
Tub material	Plastic – Slate	Stainless steel	Stainless steel	Stainless steel
Sound package	Quiet Partner™ II (55 dBA**)	Quiet Partner™ IV (51 dBA**)	Quiet Partner™ IV (51 dBA**)	Quiet Partner™ IV (51 dBA**)
30-Day Clean & Quiet guarantee††	◆	•	•	•
Designed, engineered and assembled in the U.S.A.	•	•	•	•
DISHWASHER SYSTEM				
5-level direct-feed Resource-efficient wash system	•	•	•	•
Auto soil sensor	◆	•	•	•
Console height	Fully integrated	2½"	Fully integrated	Fully integrated
Electronic controls	•	•	•	•
CYCLES				
Total number of cycles	6	5	6	6
Sensor	◆	•	•	•
Eco Wash	•	•	•	•
Overnight	•	•	◆	•
1-Hour Wash	•	•	•	•
Heavy	•	•	•	•
Normal	•	•	•	•
OPTIONS				
Total number of options	7	6	7	7
Eco Dry	◆	•	•	•
Heated Dry	•	•	•	•
Top Rack Wash	◆	•	◆	•
PowerScour™	•	•	•	◆
Sani Rinse	◆	•	•	•
High Temperature Wash	•	•	•	•
Delay Wash	4 Hour	2-4-8 Hour	4 Hour	4 Hour
Control lock	•	•	•	•
RACK FLEXIBILITY				
Nylon rack coating	•	•	•	•
Adjustable upper rack	◆	•	◆	EZ-2-Lift™
Light item clips	2	2	2	2
Cup shelves	•	•	•	•
EZ Adjustable tines	•	•	•	◆
2 Upper rack fold-down tines	◆	•	•	◆
Lower rack fold-down tines	•	•	•	◆
AnyWare™ Plus silverware basket	◆	•	•	•
Premium rail system	•	•	•	◆
DIMENSIONS AND COLORS				
Height (A)	33½"-34½"	33½"-34½"	33½"-34½"	33½"-34½"
Width (B)	23¾"	23¾"	23¾"	23¾"
Depth (C)	24½"	24½"	24½"	24½"
Minimum cutout height (D)	34"	34"	34"	34"
Cutout width (E)	24"	24"	24"	24"
Cutout depth (F)	24"	24"	24"	24"
Available colors	W B M H E	W B M	W B M	M H E

Bold type indicates a step-up feature

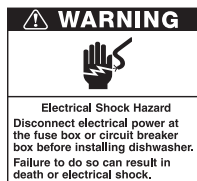

Electrical requirements

Rated load is 11.0 amps, 120 volts, 60 Hz AC.
15-amp (20-amp max) circuit required.

When local codes permit, any Whirlpool® dishwasher plus a disposer up to 7.2 amps can be installed on a single 20-amp circuit. Do not use an extension cord.

Water Pressure — 15 to 120 psi.

Recommended incoming water temperature — 120°F minimum.

Listed by Underwriters Laboratories.

*Based on the Consortium for Energy Efficiency qualifying product lists. Visit cee1.org for more information. **Per IEC standards. ††Visit whirlpool.com for complete details and qualified models.

DIMENSIONS ARE SHOWN FOR PLANNING PURPOSES ONLY.
For complete information, see Installation Instructions packed with product.

Compact Dishwasher

SPECIFICATIONS AND DIMENSIONS

WHIRLPOOL®	
MODEL	WDF518SAA
Place setting capacity	8
ENERGY STAR® qualified	.
Tall tub design	.
Tub material	Stainless steel
Sound package	Quiet Partner™ I (57 dBA)
WASH SYSTEM	
4-level direct-feed Resource-efficient wash system	.
Console height	5"
Electronic controls	.
CYCLES	
Total number of cycles	5
Pots & Pans	.
Heavy	.
Normal	.
Quick Wash	.
Rinse Only	.
OPTIONS	
Total number of options	2
Heated Dry	.
Delay Wash	2-4-8 Hour
RACK FLEXIBILITY	
Vinyl rack coating	.
Cup shelves	.
Silverware basket	In-the-Rack
DIMENSIONS AND COLORS	
Height (A)	32 1/2"–35"
Width (B)	17 1/2"–18"
Depth (C)	22"
Minimum cutout height (D)	34"
Cutout width (E)	17 3/8"–18"
Cutout depth (F)	24"
Available colors	W B M

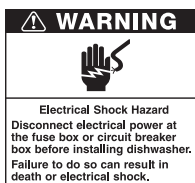

Electrical requirements

Rated load is 11.0 amps, 120 volts, 60 Hz AC.

15-amp (20-amp max) circuit required.

When local codes permit, any Whirlpool® dishwasher plus a disposer up to 7.2 amps can be installed on a single 20-amp circuit. Do not use an extension cord.

Water Pressure — 15 to 120 psi.

Recommended incoming water temperature — 120°F minimum.

Listed by Underwriters Laboratories.

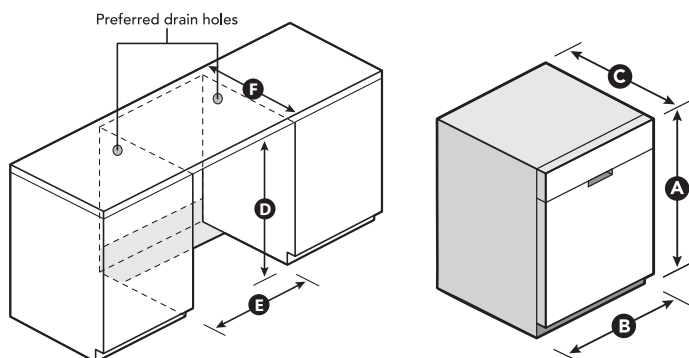

*Per IEC standards.

Portable Dishwasher

SPECIFICATIONS AND DIMENSIONS

WHIRLPOOL®	
MODEL	WDP350PAA
Place setting capacity	12
ENERGY STAR® qualified	-
Tall tub design	-
Tub material	White plastic
Sound package	Quiet Partner™ I (63 dBA)
Designed, engineered and assembled in the U.S.A.	-
WASH SYSTEM	
4-level Resource-efficient wash system	-
Electronic controls	-
CYCLES	
Total number of cycles	3
Heavy	-
1-Hour Wash	-
Normal	-
OPTIONS	
Total number of options	4
Heated Dry	-
High Temperature Wash	-
Delay Wash	4 Hour
Control lock	-
RACK FLEXIBILITY	
Vinyl rack coating	-
Silverware basket	In-the-Rack
DIMENSIONS AND COLORS	
Height (A)	37"
Width (B)	24½"
Depth (C)	26½"
Available colors	W B

Dishwasher Custom Panels

SPECIFICATIONS AND DIMENSIONS

DIMENSIONS	4" FRAMELESS	4" FRAMED
Height (A)	25 ²⁹ / ₃₂ "	26"
Width (B)	23 ³ / ₁₆ "	23 ¹ / ₄ "
Thickness (C)	¾"	¼"

Installation Notes

1. Custom panel for door cannot exceed 8-lb weight
2. Upper and lower panels are not the same width
3. Match woodgrain direction with that of adjacent cabinets
4. Sand panel edges to provide a smooth finish
5. Use moisture-resistant sealer on sides and edges of panels to protect from humidity (Dishwasher is subject to humidity)

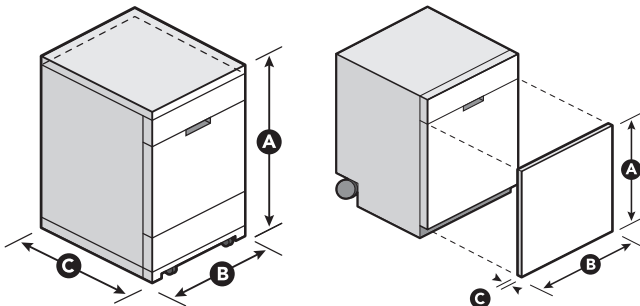

*Per IEC standards.

DIMENSIONS ARE SHOWN FOR PLANNING PURPOSES ONLY.
For complete information, see Installation Instructions packed with product.

Food Disposers

SPECIFICATIONS AND DIMENSIONS

MODEL	GC1000XE/PE*	GC2000XE/PE*	GC5000XE
Motor	1/3-HP	1/2-HP	3/4-HP
Locked-in mounting	•	•	•
Continuous-feed operation	•	•	•
Stainless steel grinding wheel			♦
Overload protector	•	•	•
Manual reset	•	•	•
Sound insulation			♦
Designed, engineered and assembled in the U.S.A.	•	•	•
DIMENSIONS			
A	11 3/8"	11 3/8"	12 3/8"
B	5 5/16"	5 5/16"	6 5/16"
C	4"	4"	4"
D	6 5/16"	6 5/16"	7 3/4"
E	5"	5"	5 1/4"

Bold type indicates a step-up feature

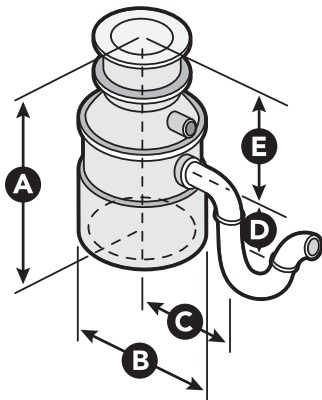

*Also available with plug and cord.

Trash Compactors

SPECIFICATIONS AND DIMENSIONS

MODEL	WHIRLPOOL GOLD®		WHIRLPOOL®
	GX900QPP	GC900GPP	TU950GPX
Capacity (cu. ft.)	1.4	1.4	1.4
Convertible freestanding-to-built-in		◆	
Under counter	•		◆
Touch pad controls	•	•	
Fully integrated controls			◆
Knob On/Off/Start			
Wrap around drawer panel	•	•	•
Automatic anti-jam	•	•	•
Clean Touch™ console	•	•	•
Touch-Toe™ drawer opener	•	•	•
"Hidden" removable key control knob	•	•	
Easy Rollers™ installation wheels	•	•	•
1/3-HP motor	•	•	•
4-to-1 Compaction ratio	•	•	•
Front levelers/rear rollers	•	•	•
Bag retainer buttons	•	•	•
Side release bin	•	•	•
Tilt-Away trash basket	•	•	•
Tilt switch	•	•	•
Designed, engineered and assembled in the U.S.A.	•	•	•
DIMENSIONS AND COLORS			
Height (A)	34 1/8"	34 1/8"	33 7/8"
Width (B)	15"	15"	15"
Depth (C)	24"	24"	24"
Minimum cutout height (D)	34 1/4"	34 1/4"	34 1/4"
Cutout width (E)	15 1/8"	15 1/8"	15 1/8"
Cutout depth (F)	24 3/4"	24 3/4"	24 3/4"
Height to outlet (G)	18"	18"	18"
Available colors	Q B S	Q B	S

Bold type indicates a step-up feature

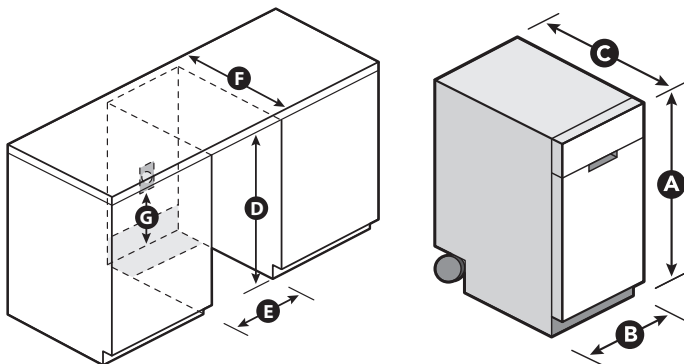

Whirlpool brand is constantly improving and innovating our products, so the specifications and dimensions in this catalog are subject to change without notice.

DIMENSIONS ARE SHOWN FOR PLANNING PURPOSES ONLY.
For complete information, see Installation Instructions packed with product.





LAUNDRY

- 184 High efficiency (HE) front load laundry
- 192 High efficiency (HE) top load laundry
- 200 Traditional top load laundry
- 207 Laundry 1-2-3™ custom laundry options
- 208 Specialty laundry pairs
- 210 Accessories
- 212 Glossary
- 214 Specifications



HIGH EFFICIENCY FRONT LOAD LAUNDRY



Colors stay vibrant

Adaptive Wash technology automatically senses and adapts to the size of each load and uses just the right amount of water to deliver great cleaning. It delivers better cleaning performance* and gentleness by combining Precision Dispense, 14 adaptive wash actions and the Care Control temperature management system.



Adds the detergent for you

Precision Dispense Ultra senses and adapts to each load, adding detergent, bleach and fabric softener at just the right time during the cycle. The removable detergent reservoir can hold enough detergent for up to 12 loads of laundry in a single filling.**



Washes and dries small loads right in the washer†

When the FanFresh® option with Dynamic Venting Technology® is activated, select models automatically tumble clothes for up to 12 hours until you're ready to toss them in the dryer.



Automatically stops when items are perfectly dry

Stop shrinking and save time and energy with Advanced Moisture Sensing. Three active built-in sensors read incoming and outgoing air temperatures and monitor moisture levels inside the dryer, while adapting the drying level to prevent overdrying.

NOTE: Not all features are available on all models.

*Compared to traditional top load washers. **Based on 2X concentration of HE detergent. †Based on a 2-lb load of lightweight fabrics.

Duet® HE Front Load Washers

RATED A
BEST BUY



WFW70HEB 4.1 cu. ft. W

Recommended dryers: WE/GD70HEB, WED71HEB
Precision Dispense
ENERGY STAR® qualified
Meets CEE Tier 3** standards
Tap Touch controls
Adaptive Wash technology
Quiet Spin 360 technology



RATED A
RECOMMENDED BUY



WFW80HEB 4.1 cu. ft. W

Recommended dryer: WE/GD80HEB
TumbleFresh™ option
Eco Sanitize option with Oxi
Eco Monitor
Precision Dispense
ENERGY STAR® qualified
Meets CEE Tier 3** standards
Tap Touch controls
Adaptive Wash technology
Quiet Spin 360 technology



*According to a leading consumer magazine. **Based on the Consortium for Energy Efficiency qualifying product lists. Visit cee1.org for more information.

Step-up features
highlighted by
yellow bar



Most Whirlpool® washers
are ENERGY STAR® qualified.

Duet® HE Dryers



WE/GD70HEB 7.4 cu. ft. W
WED71HEB 7.4 cu. ft. W

Recommended washer: WFW70HEB
Tap Touch controls
Advanced Moisture Sensing
140-minute Wrinkle Shield™ Plus option
Quiet Dry Ultra system
Long vent†



**RATED A
RECOMMENDED BUY***



WE/GD80HEB 7.4 cu. ft. W

Recommended washer: WFW80HEB
Eco Monitor
Tap Touch controls
Advanced Moisture Sensing
140-minute Wrinkle Shield™ Plus option
Quiet Dry Ultra system



*According to a leading consumer magazine. †Model WED71HEB only.

Feature descriptions can be found in the glossary on pages 212–213. Complete product specifications can be found on pages 214–215.

Duet® HE Front Load Washers

RATED A
RECOMMENDED BUY*



WFW86HEB 4.1 cu. ft. W | C

Recommended dryer: WE/GD86HEB

Sanitize cycle with Steam and Heater

Precision Dispense

TumbleFresh™ option

ENERGY STAR® qualified

Meets CEE Tier 3** standards

Eco Monitor

Tap Touch controls

Adaptive Wash technology

Quiet Spin 360 technology



RATED A
RECOMMENDED BUY*



WFW88HEA 4.3 cu. ft. W | C

Recommended dryer: WE/GD88HEA

EcoBoost™ option with Eco Monitor

Steam-enhanced cycles

Precision Dispense

TumbleFresh™ option

ENERGY STAR® qualified

Meets CEE Tier 3** standards

Sanitize cycle with Steam and Heater

Tap Touch controls

Adaptive Wash technology

Quiet Spin 360 technology



*According to a leading consumer magazine. **Based on the Consortium for Energy Efficiency qualifying product lists. Visit cee1.org for more information.

Step-up features
highlighted by
yellow bar



Most Whirlpool® washers
are ENERGY STAR® qualified.

Duet® HE Dryers



WE/GD86HEB 7.4 cu. ft. W | C

Recommended washer: WFW86HEB

Steam Refresh cycle

140-minute Wrinkle Shield™ Plus option with Steam

Tap Touch controls

Advanced Moisture Sensing

Eco Monitor

Quiet Dry Ultra system



**RATED A
RECOMMENDED BUY***



WE/GD88HEA 7.4 cu. ft. W | C

Recommended washer: WFW88HEA

EcoBoost™ option with Eco Monitor

Steam-enhanced cycles

Tap Touch controls

Advanced Moisture Sensing

140-minute Wrinkle Shield™ Plus option with Steam

Quiet Dry Ultra system



*According to a leading consumer magazine.

Feature descriptions can be found in the glossary on pages 212–213. Complete product specifications can be found on pages 214–215.

Duet® HE Front Load Washers



WF94HEA 4.3 cu. ft. W | C

Recommended dryer: WE/GD94HEA

12-hour FanFresh® option with Dynamic Venting Technology®

Precision Dispense

ENERGY STAR® qualified

Meets CEE Tier 3* standards

EcoBoost™ option with Eco Monitor

Steam-enhanced cycles

Sanitize cycle with Steam and Heater

Tap Touch controls

Adaptive Wash technology

Quiet Spin 360 technology



RATED A
RECOMMENDED BUY**



WF96HEA 4.3 cu. ft. W | C | U

Recommended dryer: WE/GD96HEA

Precision Dispense Ultra

Active Spray technology

12-hour FanFresh® option with Dynamic Venting Technology®

ENERGY STAR® qualified

Meets CEE Tier 3* standards

EcoBoost™ option

Steam-enhanced cycles

Sanitize cycle with Steam and Heater

Tap Touch controls

Adaptive Wash technology

Quiet Spin 360 technology



*Based on the Consortium for Energy Efficiency qualifying product lists. Visit cee1.org for more information. **According to a leading consumer magazine.

Step-up features
highlighted by
yellow bar



Most Whirlpool® washers
are ENERGY STAR® qualified.

Duet® HE Dryers

RATED A
RECOMMENDED BUY**



WE/GD94HEA 7.4 cu. ft. W | C

Recommended washer: WFW94HEA

Static Reduce option

- Tap Touch controls
- Advanced Moisture Sensing
- EcoBoost™ option with Eco Monitor
- Steam-enhanced cycles
- 140-minute Wrinkle Shield™ Plus option with Steam
- Quiet Dry Ultra system

RATED A
RECOMMENDED BUY**



WE/GD96HEA 7.4 cu. ft. W | C | U

Recommended washer: WFW96HEA

SilentSteel™ dryer drum

- Tap Touch controls
- Advanced Moisture Sensing
- EcoBoost™ option with Eco Monitor
- Steam-enhanced cycles
- 140-minute Wrinkle Shield™ Plus option with Steam
- Static Reduce option
- Quiet Dry Ultra system

**According to a leading consumer magazine.

Feature descriptions can be found in the glossary on pages 212–213. Complete product specifications can be found on pages 214–215.



HIGH EFFICIENCY TOP LOAD LAUNDRY



Colors stay vibrant

Adaptive Wash technology automatically senses and adapts to the size of each load and uses just the right amount of water to deliver great cleaning. It delivers better cleaning performance* and gentleness by combining Precision Dispense, 11 adaptive wash actions and the Care Control temperature management system.



Saves over \$3,300 in lifetime energy costs**

Save time, money and energy with an ENERGY STAR® qualified washer and high-efficiency dryer. These laundry pairs more than pay for themselves** while using less water and electricity.



Wash more than three baskets of laundry in one load

Take care of all your laundry needs with a washer and dryer that's designed to handle large loads. Wash multiple baskets of laundry inside the 4.8 cu. ft. washer. Then transfer your laundry to the 7.6 cu. ft. dryer that easily adapts to both small and large loads for optimal fabric care.



Stops drying when items are ready

Whirlpool brand brings high efficiency to the dryer with Advanced Moisture Sensing and the AccuDry™ sensor drying system. Stop shrinking and save time and energy with HE Cabrio® dryers that monitor moisture levels and end the cycle when everything is dry.

NOTE: Not all features are available on all models.

*Compared to traditional top load washers. **Compared to pre-2004 traditional top load washers and dryers, based on average use, using normal cycle, 11-year average washer life and 12-year average dryer life, electric models only.

Cabrio® HE Top Load Washers



WTW5500B 3.8 cu. ft. W

Recommended dryer: WE/GD5500B
Adaptive Wash technology
Precision Dispense
Cold Wash cycle
Smooth impeller
Smooth Spiral stainless steel wash basket
ENERGY STAR® qualified
Meets CEE Tier 3* standards
Wide open lid
Deep Water Wash cycle



WTW5800B 3.8 cu. ft. W | C

Recommended dryer: WE/GD5800B
EcoBoost™ option with Eco Monitor
Presoak option
EasyView™ framed glass lid
Estimated time remaining LED display
Deep Clean option
Delay Wash option
Adaptive Wash technology
Precision Dispense
Cold Wash cycle
Smooth impeller
Smooth Spiral stainless steel wash basket
ENERGY STAR® qualified
Meets CEE Tier 3* standards
Deep Water Wash cycle

*Based on the Consortium for Energy Efficiency qualifying product lists. Visit cee1.org for more information.

Step-up features
highlighted by
yellow bar



Most Whirlpool® washers
are ENERGY STAR® qualified.

Cabrio® HE Dryers



WE/GD5500B 7.4 cu. ft. W

Recommended washer: WTW5500B
AccuDry™ sensor drying system
90-minute Wrinkle Shield™ option
Quiet Dry noise reduction system
Drum light
Hamper door



WE/GD5800B 7.4 cu. ft. W | C

Recommended washer: WTW5800B
EcoBoost™ option with Eco Monitor
150-minute Wrinkle Shield™ option
Sanitize cycle
Eco Normal cycle
Estimated time remaining LED display
On/Off drum light
Hamper door with window
Damp Dry signal
AccuDry™ sensor drying system
Quiet Dry noise reduction system

Feature descriptions can be found in the glossary on pages 212–213. Complete product specifications can be found on pages 216–217.

Cabrio® Platinum HE Top Load Washers



WTW800B 4.5 cu. ft. W

Recommended dryer: WE/GD8000B

Precision Dispense Plus

Direct drive motor

Quiet Wash Ultra noise reduction system

Adaptive Wash technology

EcoBoost™ option with Eco Monitor

Smooth impeller

Smooth Spiral stainless steel wash basket

ENERGY STAR® qualified

Meets CEE Tier 3* standards

Delay Wash option

Estimated time remaining LED display



WTW8100B 4.5 cu. ft. W

Recommended dryer: WE/GD8100B

EasyView™ framed glass lid

Adaptive Wash technology

Precision Dispense Plus

EcoBoost™ option with Eco Monitor

Smooth impeller

Smooth Spiral stainless steel wash basket

Direct drive motor

ENERGY STAR® qualified

Meets CEE Tier 3* standards

Quiet Wash Ultra noise reduction system

Delay Wash option

Estimated time remaining LED display

*Based on the Consortium for Energy Efficiency qualifying product lists. Visit cee1.org for more information.

Step-up features
highlighted by
yellow bar



Most Whirlpool® washers
are ENERGY STAR® qualified.

Cabrio® Platinum HE Dryers



WE/GD8000B 7.6 cu. ft. W

Recommended washer: WTW8000B

- Advanced Moisture Sensing
- Quiet Dry Ultra noise reduction system
- On/Off Damp Dry signal
- Reversible side-swing door
- EcoBoost™ option with Eco Monitor
- 150-minute Wrinkle Shield™ option
- Sanitize cycle
- Estimated time remaining LED display
- Drum light



WE/GD8100B 7.6 cu. ft. W

Recommended washer: WTW8100B

- Reversible side-swing door with window
- Advanced Moisture Sensing
- EcoBoost™ option with Eco Monitor
- 150-minute Wrinkle Shield™ option
- Sanitize cycle
- Quiet Dry Ultra noise reduction system
- Estimated time remaining LED display
- Drum light
- On/Off Damp Dry signal

Feature descriptions can be found in the glossary on pages 212–213. Complete product specifications can be found on pages 218–219.

Cabrio® Platinum HE Top Load Washers



WTW8500B 4.8 cu. ft. W | C

Recommended dryer: WE/GD8500B

Cold Wash cycle

Unique soft-touch impeller

Soak cycle

Active Wear cycle

Adaptive Wash technology

Precision Dispense Plus

EcoBoost™ option with Eco Monitor

Smooth Spiral stainless steel wash basket

Direct drive motor

ENERGY STAR® qualified

Meets CEE Tier 3* standards

Quiet Wash Ultra noise reduction system

EasyView™ framed glass lid

Delay Wash option

Estimated time remaining LED display



WTW8900B 4.8 cu. ft. W | C

Recommended dryer: WE/GD8900B

Deep Clean option with Heater

Sanitary cycle with Steam and Oxi

EasyView™ frameless glass lid with slow-close hinge

Deep Water Soak cycle

Chrome accents

Adaptive Wash technology

Precision Dispense Plus

Cold Wash cycle

EcoBoost™ option with Eco Monitor

Unique soft-touch impeller

Smooth Spiral stainless steel wash basket

Direct drive motor

ENERGY STAR® qualified

Meets CEE Tier 3* standards

Quiet Wash Ultra noise reduction system

Active Wear cycle

Delay Wash option

Estimated time remaining LED display

*Based on the Consortium for Energy Efficiency qualifying product lists. Visit cee1.org for more information.

Step-up features
highlighted by
yellow bar



Most Whirlpool® washers
are ENERGY STAR® qualified.

Cabrio® Platinum HE Dryers



WE/GD8500B 7.6 cu. ft. W | C

Recommended washer: WTW8500B

Enhanced Touch Up Steam cycle

Active Wear cycle

Advanced Moisture Sensing

EcoBoost™ option with Eco Monitor

150-minute Wrinkle Shield™ option

Sanitize cycle

Quiet Dry Ultra noise reduction system

Estimated time remaining LED display

Drum light

On/Off Damp Dry signal

Reversible side-swing door with window



WE/GD8900B 7.6 cu. ft. W | C

Recommended washer: WTW8900B

Quick Refresh Steam cycle

150-minute Wrinkle Shield™ Plus option with Steam

Static Reduce option

Chrome accents

Advanced Moisture Sensing

EcoBoost™ option with Eco Monitor

Enhanced Touch Up Steam cycle

Sanitize cycle

Quiet Dry Ultra noise reduction system

Estimated time remaining LED display

Drum light

On/Off Damp Dry signal

Active Wear cycle

Reversible side-swing door with window

Feature descriptions can be found in the glossary on pages 212–213. Complete product specifications can be found on pages 218–219.



TRADITIONAL TOP LOAD LAUNDRY



Saves water and energy

Whirlpool® traditional laundry pairs not only feature a new and improved design, but they also include ENERGY STAR® qualified washers. Select models with Adaptive Wash technology even meet the CEE Tier 3* standard.



Tracks progress

All Whirlpool brand traditional washers let you clearly see which part of the cycle your washer is running, including Sensing, Wash, Rinse, Spin, Done and Lid Lock.



Gently lifts stains

The Deep Water Wash cycle helps break down loose soils, while the Cold Wash cycle gently lifts stains and soils from fabrics. It uses adaptive wash actions, a concentrated solution of HE detergent and cold water to deliver great cleaning and protect fabrics.



Uses less energy

The AccuDry™ sensor drying system uses less energy than dryers equipped with the AutoDry™ system,** helping to lower your monthly electric bills. The sensor drying system reduces overdrying by monitoring moisture levels and temperatures.

NOTE: Not all features are available on all models.

*Based on the Consortium for Energy Efficiency qualifying product lists. Visit cee1.org for more information. **Electric models only.

Traditional Top Load Washers



WTW4800B 3.6 cu. ft. Q

- Recommended dryer: WE/GD4800B
- Smooth motion agitator
- Wide open lid
- Cycle status bar
- Quiet Spin technology
- Extra Rinse option with Fabric Softener
- Extra-large Load Size option



WTW4850B 3.6 cu. ft. W

- Recommended dryers: WE/GD4850B, WE/GD4890B
- Cold Wash cycle
- Deep Water Wash cycle
- ENERGY STAR® qualified
- Presoak option
- Soak cycle
- Quick Wash cycle
- Smooth motion agitator
- Wide open lid
- Cycle status bar
- Quiet Spin technology
- Extra Rinse option with Fabric Softener

Step-up features highlighted by yellow bar



Most Whirlpool® washers are ENERGY STAR® qualified.

Traditional Dryers



WE/GD4800B 7.0 cu. ft. Q

Recommended washer: WTW4800B
AutoDry™ drying system
40-minute Wrinkle Shield™ option
Reversible side-swing door



WE/GD4850B 7.0 cu. ft. HIGH EFFICIENCY W

Recommended washers: WTW4850B, WTW4900B
AccuDry™ sensor drying system
90-minute Wrinkle Shield™ option
Wide-opening hamper door
Drum light

Feature descriptions can be found in the glossary on pages 212–213. Complete product specifications can be found on pages 220–221.

Traditional Top Load Washers



WTW4900B 3.8 cu. ft. HIGH EFFICIENCY W

Recommended dryers: WE/GD4850B, WE/GD4890B

Smooth impeller

Smooth Spiral stainless steel wash basket

Meets CEE Tier 3* standards

Cold Wash cycle

Deep Water Wash cycle

ENERGY STAR® qualified

Presoak option

Soak cycle

Wide open lid

Quick Wash cycle

Cycle status bar

Quiet Spin technology

Extra Rinse option with Fabric Softener

*Based on the Consortium for Energy Efficiency qualifying product lists. Visit cee1.org for more information.

Step-up features
highlighted by
yellow bar



Most Whirlpool® washers
are ENERGY STAR® qualified.

Traditional Dryers



WE/GD4890B 6.4 cu. ft. HIGH EFFICIENCY W

Recommended washers: WTW4850B, WTW4900B

Smooth, flat back design

AccuDry™ sensor drying system

90-minute Wrinkle Shield™ option

Reversible side-swing door

Drum light

Feature descriptions can be found in the glossary on pages 212–213. Complete product specifications can be found on pages 220–221.

Duet® Laundry Pair Installation

INNOVATIONS THAT FIT YOUR LIFE AND HOME



The best-selling laundry appliance brand in the U.S.A.* offers washers and dryers that are carefully crafted to fit seamlessly into your life and home. Innovative features help get you out of the laundry room and back to doing what you love to do. Our 27" design fits through doors and hallways so you don't have to dismantle the home you're trying to complete.

Models: Duet® washer WFW96HEAU and Duet® dryer WE/GD96HEAU with optional 15.5" pedestals XHPC155YU

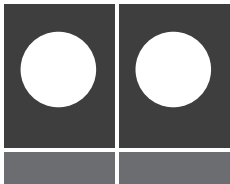

Use 10" pedestals to place doors at the best height for customers shorter than 5'4" tall.

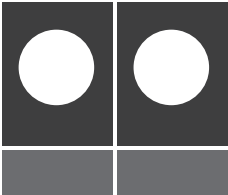

Add 15.5" pedestals to place doors at the best height for customers 5'4" or taller.



Superb vibration control systems mean upstairs installation is always possible.

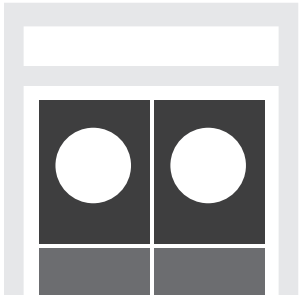

Installation in a standard closet places the laundry area close to living spaces. Even in a closet, full-sized pairs may be stacked or placed side-by-side with or without pedestals.



When stacked,** the dryer controls are still at a comfortable height. Plus, a direct water hookup for the steam dryer means no reservoir to fill.

*Traqline, 2013. **Requires stack kit, see page 210 for accessory information.

Laundry 1-2-3™ Pedestals



Using height as a guide, choose the recommended pedestal while also taking into consideration the height of any cabinets above your laundry pair.

Height	Recommended Pedestal	Approx. Height with Pedestal
5'4" and up	15.5"	53.5"
Under 5'4"	10"	48"

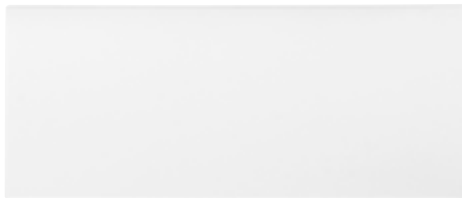

LAB0050P Q

12" Height

Recommended for compact laundry pairs

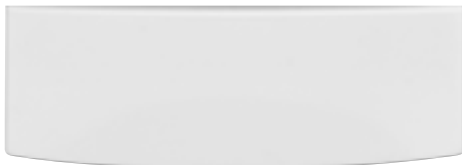

XHP1000X W

10" Height

Recommended for all Duet® front load laundry pairs



XHPC155X W XHPC155Y C | U

Chrome handle

Storage drawer

15.5" Height

Recommended for all Duet® front load laundry pairs



Feature descriptions can be found in the glossary on pages 212–213. Complete product specifications can be found on page 225.

Thin Twin® Laundry Centers



LTE/G5243D 4.9 total cu. ft. Q

DRYER

3.4 cu. ft. dryer capacity
18 cycles / 4 temperatures

WASHER

1.5 cu. ft. washer capacity
Surgilator® agitator
Tough Top™ II top and lid
5 cycles / 4 temperatures



WE/GT3300X 8.4 total cu. ft. Q

DRYER

5.9 cu. ft. dryer capacity
6 cycles / 3 temperatures

WASHER

2.5 cu. ft. washer capacity
Two-piece Surgilator® agitator
8 cycles / 4 temperatures

Step-up features
highlighted by
yellow bar



Most Whirlpool® washers
are ENERGY STAR® qualified.

Compact Laundry Pairs



WED7500V 3.8 cu. ft. W

DRYER

- AutoDry™ drying system
- Stainless steel dryer drum
- Moisture sensor control
- Dryer stack kit included
- 11 cycles / 2 temperatures

WFC7500V 2.0 cu. ft. W

WASHER

- ENERGY STAR® qualified
- Meets CEE Tier 1* standards
- Stainless steel wash basket
- Cycle status bar
- Estimated time remaining display
- 8 cycles / 3 temperatures



Shown with optional stack stand (49971)

LER3622P 3.4 cu. ft. Q

DRYER

- 3 cycles / 2 temperatures

LDR3822P 3.4 cu. ft. Q

DRYER

- AccuDry™ sensor drying system
- 3 cycles / 2 temperatures

LCE4332P 2.1 cu. ft. Q

WASHER

- Straight vane agitator
- 4 cycles / 3 temperatures

*Based on the Consortium for Energy Efficiency qualifying product lists. Visit cee1.org for more information.

Feature descriptions can be found in the glossary on pages 212–213. Complete product specifications can be found on pages 222–224.

Accessories



affresh® Washer Cleaner (W10135699)

Effectively remove odor-causing residue in all washers. Keeps your machine fresher and cleaner when used monthly. Contains 3 pucks.



Front Load Stack Kits (W10298318RP)

Install a 7.5 cu. ft. front load dryer on top of its matching washer with this stack kit. Retail polybag over pack of 12.



Precision Dispense HE Detergent Dispenser (W10250743A)

Adds the right amount of detergent at the right time during the cycle. Extra dispenser provides flexibility in changing detergent.



Compact Model Stack Stand (49971)

Install compact dryer model LER3622P or LDR3822P on top of the LCE4332P compact washer model with this stack stand.



Washable Delicates Bag (W10180464RP)

Protect delicate items from snags, tangles and tears while machine washing and drying. 15-1/2" (L) x 16-1/2" (W).



Dryer Lint Brush (8212614)

Extend dryer life, lower utility bills and reduce drying time by regularly and thoroughly removing lint with this cleaning brush. For lint screen on top. Size 40" (L) x 2" (W) x 2" (D).



Laundry 1-2-3™ Adjustable Clothes Rack (XHS1000XX)

Hang garments straight from the washer or dryer with this clothes rack. It's also collapsible for quick, easy storage.



Top Load Washer/Dryer Cover (W10214580RP)

Protect your top load washer or dryer from environmental damage with this gray cover. The cover also cleans easily with a damp cloth.



Industrial-Grade Washer Hoses 8212638RP: (2) 6' Nylon Braided w/90° elbow

8212487RP: (2) 5' Nylon Braided
8212545RP: (2) 5' Red & Blue EPDM
8212656RP: (2) 10' Black EPDM
8212546RP: (2) 4' Black EPDM
8212641RP: (2) 5' Black EPDM

Industrial strength hoses safely and efficiently transport hot and cold water to the washer.

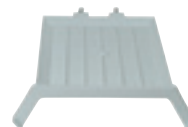

Dryer Racks

Models 70HEB, 71HEB, 80HEB, 86HEB, 88HEA, 94HEA, 96HEA: W10322470A
Models 8000B, 8100B, 8500B and 8900B: 8577312A
Models 5500B and 5800B: 8212450A
Models 4800B and 4850B: 3406839

The dryer rack is convenient for flat items such as sweaters and hats, or for bulky items like footwear and stuffed animals. A quick and easy insertion of this lightweight rack means tumble-free drying.



Steam Dryer Hose kit Models 86HEB, 88HEA, 94HEA, 96HEA: W10473735

This dryer hose kit is especially made for steam dryers and includes (1) 5' hook-up hose, (1) 2' hook-up hose and O-rings.

To acquire pricing information, order Whirlpool® laundry accessories and determine delivery time, visit whirlpool.com/accessories or call 1-800-462-3819.

Accessories

Optional Accessories



DRYER CORDS	
4', 3-wire, 30 amp	PT220L
4', 4-wire, 30 amp	PT400L
6', 4-wire, 30 amp	PT600L
Gas dryer connector kit	20-48KITRC

LP GAS CONVERSION KITS	
24" Thin Twin® laundry and compacts	49573 (10,500 BTU)
27" Thin Twin® laundry centers	3392235 (16,000 BTU)
Full-size gas dryers (lint screen on top)	49572A (22,000 BTU)
Duet® dryers (70HEB, 80HEB, 86HEB, 88HEA, 94HEA and 96HEA)	W10307153 (20,000 BTU)
Duet® dryers (lint screen front)*	W10317689 (20,000 BTU)

WASHER ACCESSORIES	
(2) 5' Reinforced braid fill hoses (all washers)	8212487RP
2' Siphon break kit (27" & 29" washers)	285834
Drain reducer kit (29" washers)	40923
4' Drain extension kit (includes coupler, 2 clamps and 4' drain hose with fitted end)	DRNEXT4

Exhaust Information

All dryers require the equivalent of a 4-inch diameter exhaust duct. Whirlpool Corporation recommends using a rigid metal duct to minimize the risk of lint fires and melted venting.

27" & 29" DRYER VENTING REQUIREMENTS	4" HOOD (4396007RW)	4" HOOD (8212662)
		
Number of 90° turns	4"	4"
0	64' / 36"	64' / 36"
1	54' / 31"	54' / 31"
2	44' / 27"	44' / 27"
3	35' / 25"	35' / 25"
4	27' / 23"	27' / 23"

24" Compact long vent drying requirements (WED7500V)

NUMBER OF 90° TURNS OR ELBOWS	TYPE OF VENT	BOX OR LOUVERED HOODS	ANGLED HOODS
0	Rigid metal / Flexible metal	90' (27.4 m) / 64' (19.5 m)	80' (24.4 m) / 58' (17.7 m)
1	Rigid metal / Flexible metal	80' (24.4 m) / 58' (17.7 m)	70' (21.3 m) / 52' (15.8 m)
2	Rigid metal / Flexible metal	70' (21.3 m) / 50' (15.2 m)	60' (18.3 m) / 42' (12.8 m)

8' DuraSafe™ Dryer Vent Installer's Kit (4396013RB)

Kit Contains:

- (1) 4' pipe section attached to (1) close elbow
- (1) 4' pipe section attached to (1) wall-offset elbow
- (1) Extension collar
- (2) Clamps for wall and dryer connection
- Installation instructions

*Refer to Use & Care Guide for specific model. **Maximum length of 4" diameter rigid metal duct and flexible metal duct.

Glossary

AccuDry™ sensor drying system

Measures moisture and temperature levels to reduce overdrying and automatically stop the cycle when the load is dry. Dryers with the AccuDry™ system use less energy than Whirlpool® top load dryers equipped with the AutoDry™ system.*

Active Spray technology

Sprays the load with detergent in a cone-shaped pattern to completely and evenly cover the fabrics.

Adaptive wash actions

Up to 14 different adaptive wash actions in front load laundry and up to 11 in top load laundry, from rocking to tumbling, adapt to the cleaning needs of each load. These adaptive wash actions provide a combination of powerful cleaning and gentle fabric care, handling everything from heavily soiled jeans to delicate silks.

Adaptive Wash technology

Colors stay vibrant as Adaptive Wash technology delivers better cleaning performance** and gentleness. It combines Precision Dispense, adaptive wash actions and the Care Control temperature management system to help clothes look their best.

Advanced Moisture Sensing

Stop shrinking with Whirlpool brand's most advanced drying system. It uses precise drying and three built-in sensors, including an inlet thermistor and moisture sensing strips, to read temperature and moisture levels, so the drying cycle can end when everything is thoroughly dry, saving time and energy.

Allergen cycle

Remove up to 95% of common allergens from your clothes with the Allergen cycle.†

AutoDry™ drying system

Automatically senses when clothes have reached the right temperature and stops the cycle to save energy.

Care Control temperature management system

Adjusts the cold and hot water inlets to reach temperatures that are warm enough to dissolve detergents. Water is kept from overheating to help reduce shrinking and color bleeding.

CEE Tier standards

Based on the Consortium for Energy Efficiency (CEE) qualifying product lists—with Tier 3 being the most efficient. These models feature advanced water and energy savings and may qualify for rebates from local utility companies. Visit cee1.org for more information.

Clean Washer cycle with affresh® Washer cleaner

Deep-fills the washer to clean areas that low-water systems don't typically reach. All it takes is one cup of bleach. Using affresh® Washer cleaner also effectively eliminates odor-causing residue and cleans mold and mildew stains.

Cold Wash cycle

Uses adaptive wash actions together with a concentrated solution of HE detergent and cold water to gently lift stains and soils from fabrics. This cycle delivers great cleaning while protecting fabrics from heat damage and using less energy.

Deep Clean option

Penetrates deep into fabric fibers, breaking down and dissolving stains without pretreating. Select models add steam enhancement for even better cleaning.

Deep Water Wash option

Helps break down loose soils and using more water and thorough cleaning.

Delay Wash option

Sets the washer to begin cleaning up to 18 hours later, during off-peak hours when utility rates may be lower or when unloading the washer is more convenient.

Direct drive motor

Handles larger capacity loads, enhances the spin speed for improved energy savings and uses fewer moving parts so there's less wear and tear over time.

EasyView™ glass lid

Framed models feature a see-through glass lid that allows you to look inside and see the wash action while the load is in progress. It features a frameless design for a larger viewable area and a Smooth Close lid that opens and closes easily without slamming.

EcoBoost™ option with Eco Monitor

In the washer, this option uses a lower temperature and increased spin speed or mechanical action to provide excellent cleaning and reduce your overall energy use. In the dryer, this option saves energy by using less heat and an increased cycle time. You can even track the energy use of this eco-friendly option with the Eco Monitor.

Eco Normal cycle

Saves up to 40% dryer energy when paired with a matching Duet® or Cabrio® washer, compared to a traditional top load laundry pair.††

ENERGY STAR® qualified

Meets government standards to help conserve natural resources and save money on your utility bills.

Fabric Sense™ wash system

Available in select top load washers, the Fabric Sense™ wash system automatically matches your needs to the optimal temperature, cycle time and agitation speed for customized care and cleaning.

FanFresh® option with Dynamic Venting Technology®

After the wash cycle, the FanFresh® option's built-in washer fan circulates air in the washer, keeping your clean clothes fresh and free from odors for up to 12 hours. When activated, select models will automatically tumble clothes for up to 12 hours. You can even wash and dry a small load right in the washer.‡

*Electric models only. **Compared to traditional top load washers. †Allergens tested were dust mites and pet dander. ††Electric models only. ‡Based on a 2-lb load of lightweight fabrics.

Glossary

High efficiency (HE) sensor drying

Whirlpool brand brings high efficiency to the dryer with models featuring AccuDry™ sensor drying systems. Select models with Advanced Moisture Sensing also save energy and deliver better cleaning by adjusting dry time and temperature as needed and stopping the cycle when clothes are dry.

Oxi Dispense option

Enhances whitening performance with an eco-friendly alternative to bleach. An automatic dispenser distributes the oxygenated additive at the appropriate time, sending oxygen through the load to brighten fabrics.

Precision Dispense

Senses and adapts to each load, adding detergent, bleach or fabric softener at just the right time. A concentrated burst of detergent showers directly onto clothes to penetrate stains and pretreat soils. Precision Dispense Plus models add the ability to release oxi additives.

Precision Dispense Ultra

Penetrates stains and pretreats soils with a concentrated burst of detergent and holds enough 2X concentration HE detergent for up to 12 loads of laundry in a single filling.

Quad dryer baffles

Four shorter, staggered baffles increase the effectiveness of the dryer and promote better, more even tumbling.

Quick Wash/Dry cycle

Designed to clean or dry small, lightly soiled loads in less time using increased spin speeds to extract more water. The Quick Dry cycle even allows you to finish drying a load in as little as 13 minutes.

Quiet Spin technology

Install your top load laundry pair on a second floor and be assured of great out-of-balance performance and vibration control. Quiet Spin 360 technology's dual-ring ball-balancing system makes it our highest level of vibration control in front load laundry.

Quiet Wash/Dry noise reduction systems

Keep operational sounds inside the washer and dryer and out of living areas with sound-absorbing materials around the wash basket and dryer drum. Escalating levels of sound reduction are available, up to Quiet Wash Ultra and Quiet Dry Ultra.

Reduce Static/Static Reduce option

Uses tumbling and a spray mist in the dryer to evenly reduce the amount of static in an entire load of clothes.

Sanitization cycles/options

Eliminate 99.9% of certain household bacteria.^{††} In select dryers, this feature provides excellent care for your clothes while eliminating 99.9% of three common household bacteria without washing.[§]

SilentSteel™ dryer drum

Forget about the sound of metal buttons and zippers making noise as they tumble, thanks to a unique sound-dampening material that surrounds the stainless steel dryer drum. The dryer runs quieter, even when you load items with metal accents.

Smooth impeller

Select high-efficiency wash systems feature a specially designed low-profile plate at the bottom of the wash basket to give you more wash capacity and better fabric care.

Smooth motion agitator

Brings your laundry to the bottom of the wash basket where cleaning takes place. It can effectively roll over and clean twice the average size load (based upon a 7-lb average load size).

Smooth Spiral stainless steel wash basket

The stainless steel wash basket resists odors and rust and features a spiral design for greater fabric care and gentle cleaning performance.

Stainless steel washer and dryer drum

The drum's stainless steel construction has a smooth surface that resists odors, rust and chipping and helps prevent fabrics from snagging or tearing.

Steam technology

In the washer, steam breaks down and dissolves tough stains without pretreating. In the dryer, features like the Enhanced Touch Up Steam cycle and Quick Refresh Steam cycle combine mist with heat to create steam to relax wrinkles and refresh dry clothes. Whirlpool® steam dryers also feature a Y-connector so you don't have to add water manually before starting a steam cycle.

Tap Touch controls

Allows direct access to washer and dryer functions, and its sleek appearance enhances the appeal of any space.

TumbleFresh™ option

Activates after the wash cycle is finished and rolls clean clothes periodically to help prevent wrinkles from setting in. Clothes stay fresh without having to transfer them to the dryer immediately.^{§§}

Unique soft-touch impeller

Moves clothes gently through the water to provide excellent cleaning performance and gentle fabric care. To protect fabrics and fibers during the wash cycle, a specially designed material fully wraps the impeller vanes.

Wrinkle Shield™/Wrinkle Shield™ Plus option with Steam

Tumbles the dryer every 5 minutes after the cycle is complete to help prevent wrinkles from setting into clean, dry fabrics. The intermittent tumbling can continue for up to 150 minutes (based on the model), or until the door is opened and the load is removed. Wrinkle Shield™ Plus option adds the power of steam to the tumbling for improved results.

^{††}Bacteria tested were *K. pneumonia*, *P. aureginosa* and *S. aureus*. [§]Bacteria tested were *K. pneumonia*, *staphylococcus aureus* and *P. aureginosa*.
^{§§}Intermittent tumbling in the washer helps reduce the growth of odor-causing bacteria.

Duet® HE Front Load Washers

SPECIFICATIONS AND DIMENSIONS

WASHER MODEL RECOMMENDED DRYER	WHIRLPOOL®					
	WFW70HEB WE/GD70HEB WED71HEB	WFW80HEB WE/GD80HEB	WFW86HEB WE/GD86HEB	WFW88HEA WE/GD88HEA	WFW94HEA WE/GD94HEA	WFW96HEA WE/GD96HEA
New 2013 model	-	-	-	-	-	-
Capacity (cu. ft.)	4.1	4.1	4.1	4.3	4.3	4.3
High-efficiency washer	-	-	-	-	-	-
ENERGY STAR® qualified	-	-	-	-	-	-
Meets CEE Tier standards*	Tier 3	Tier 3	Tier 3	Tier 3	Tier 3	Tier 3
Water use/Energy use**	77% less / 81% less	77% less / 81% less	77% less / 81% less	83% less / 85% less	83% less / 85% less	83% less / 85% less
Tap Touch controls	-	-	-	-	-	-
Estimated time remaining display	LED	LED	LED	LED	LED	LED
Eco Monitor	-	◆	-	-	-	-
Add-a-Garment indicator	-	-	-	-	-	-
End-of-cycle signal	-	On/Off	On/Off	On/Off	On/Off	On/Off
LED basket light	-	-	-	-	On/Off	On/Off
Stainless steel wash basket	-	-	-	-	-	-
Water heater	-	-	◆	-	-	-
Designed, engineered and assembled in the U.S.A.	-	-	-	-	-	-
WASH SYSTEM						
Active Spray technology	-	-	-	-	-	◆
Adaptive Wash technology	-	-	-	-	-	-
Precision Dispense	-	-	-	-	-	Ultra
Adaptive wash actions	14	14	14	14	14	14
Automatic dispensers	Detergent, bleach, fabric softener	Detergent, bleach, fabric softener	Detergent, bleach, fabric softener	Detergent, bleach, fabric softener	Detergent, bleach, fabric softener	Bulk detergent, bleach, fabric softener
Care Control temperature management system	-	-	-	-	-	-
Quiet Spin 360 technology	-	-	-	-	-	-
Quiet Wash Ultra system	-	-	-	-	-	-
Max spin speed (RPM)	up to 1,200	up to 1,200	up to 1,200	up to 1,400	up to 1,400	up to 1,400
Total number of temperatures	4	4	4	4	5	5
Suds sensor	-	-	-	-	-	-
CYCLES AND OPTIONS						
Total number of cycles	7	9	10	11	12	12
Steam-enhanced cycles	-	-	-	◆	-	-
Wash and Dry cycle	-	-	-	-	◆	-
Quick Wash cycle	-	-	-	-	-	-
Delicate cycle	-	-	-	-	-	-
Cold Wash cycle	-	-	-	-	-	-
Normal cycle	-	-	-	-	-	-
Whites cycle	-	◆	-	-	-	-
Heavy Duty cycle	-	-	-	-	-	-
Towels cycle	-	-	◆	-	-	-
Allergen cycle	-	-	-	◆	-	-
Sanitize cycle	-	Eco with Oxi	with Steam	with Steam	with Steam	with Steam
Clean Washer cycle with affresh® Washer cleaner	-	-	-	-	-	-
EcoBoost™ option	-	-	-	◆	-	-
FanFresh® option with Dynamic Venting Technology®	-	-	-	-	12-hour	12-hour
TumbleFresh™ option	-	◆	-	-	-	-
Deep Clean option	-	-	with Steam	with Steam	with Steam	with Steam
Delay Wash option	up to 8 hours	up to 8 hours	up to 8 hours	up to 12 hours	up to 12 hours	up to 12 hours
Presoak option	-	-	◆	-	-	-
Steam Clean option	-	-	◆	-	-	-
ACCESSORIES						
Pedestal	XHPC155X	XHPC155X	XHPC155X/Y	XHPC155X/Y	XHPC155X/Y	XHPC155X/Y
Washer detergent cartridge	-	-	-	-	-	W10250743A
5' Washer Inlet Hose kit (2 pack)	8212641RP	8212641RP	8212641RP	8212641RP	8212641RP	8212641RP
Washer drip tray	8212526	8212526	8212526	8212526	8212526	8212526
DIMENSIONS AND COLORS						
Max height (A)	39 3/4"	39 3/4"	39 3/4"	39 3/4"	39 3/4"	39 3/4"
Width (B)	27"	27"	27"	27"	27"	27"
Depth (C)	33 1/2"	33 1/2"	33 1/2"	33 3/8"	33 3/8"	33 3/8"
Depth with door open (D)	52 3/4"	52 3/4"	52 3/4"	52 3/4"	52 3/4"	52 3/4"
Available colors	W	W	W C	W C	W C	W C U

Bold type indicates a step-up feature

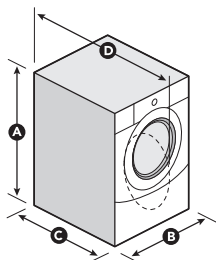

*Based on the Consortium for Energy Efficiency qualifying product lists. Visit cee1.org for more information.
**Compared to pre-2004 traditional top load washers.

DIMENSIONS ARE SHOWN FOR PLANNING PURPOSES ONLY.
For complete information, see Installation Instructions packed with product.

Duet® HE Dryers

SPECIFICATIONS AND DIMENSIONS

DRYER MODEL	WHIRLPOOL®						
	WED70HEB WGD70HEB	WED71HEB	WED80HEB WGD80HEB	WED86HEB WGD86HEB	WED88HEA WGD88HEA	WED94HEA WGD94HEA	WED96HEA WGD96HEA
RECOMMENDED WASHER	WFW70HEB	WFW70HEB	WFW80HEB	WFW86HEB	WFW88HEA	WFW94HEA	WFW96HEA
New 2013 model	-	-	-	-	-	-	-
Capacity (cu. ft.)	7.4	7.4	7.4	7.4	7.4	7.4	7.4
High-efficiency dryer	•	•	•	•	•	•	•
Tap Touch controls	•	•	•	•	•	•	•
Estimated time remaining LED display	•	•	•	•	•	•	•
Eco Monitor	•	•	♦	•	•	•	•
Damp Dry signal	•	•	Loud/Soft/Off	Loud/Soft/Off	Loud/Soft/Off	Loud/Soft/Off	Loud/Soft/Off
End-of-cycle signal	•	•	On/Off	On/Off	On/Off	On/Off	On/Off
Dryer drum	Powder coated	Powder coated	Powder coated	Powder coated	Stainless steel	Stainless steel	SilentSteel™
Drum light	•	•	♦	LED	LED	LED	LED
Quad baffles	•	•	•	•	•	•	•
Long vent	•	♦	•	•	•	•	•
Designed, engineered and assembled in the U.S.A.	•	•	•	•	•	•	•
DRYING SYSTEM							
Advanced Moisture Sensing	•	•	•	•	•	•	•
Quiet Dry Ultra system	•	•	•	•	•	•	•
Timed dry	•	•	•	•	•	•	•
Total number of temperatures	4	4	4	5	5	5	5
CYCLES AND OPTIONS							
Total number of cycles	6	6	7	9	10	10	10
Steam-enhanced cycles	•	•	•	•	♦	•	•
Quick Dry cycle	•	•	•	•	•	•	•
Delicate cycle	•	•	•	•	•	•	•
Casual cycle	•	•	♦	•	•	•	•
Normal cycle	•	•	•	•	•	•	•
Bulky Items cycle	•	•	•	•	•	•	•
Heavy Duty cycle	•	•	•	•	•	•	•
Towels cycle	•	•	•	•	♦	•	•
Sanitize cycle	•	•	•	•	•	•	•
Steam Refresh cycle	•	•	•	♦	•	•	•
EcoBoost™ option	•	•	•	•	♦	•	•
Wrinkle Shield™ Plus option	up to 140 minutes	up to 140 minutes	up to 140 minutes	up to 140 minutes with Steam	up to 140 minutes with Steam	up to 140 minutes with Steam	up to 140 minutes with Steam
Static Reduce option	•	•	•	•	•	♦	•
ACCESSORIES							
Pedestal	XHPC155X	XHPC155X	XHPC155X	XHPC155X/Y	XHPC155X/Y	XHPC155X/Y	XHPC155X/Y
Dryer rack	W10322470A	W10322470A	W10322470A	W10322470A	W10322470A	W10322470A	W10322470A
Duet® Stack kit	W10298318RP	W10298318RP	W10298318RP	W10298318RP	W10298318RP	W10298318RP	W10298318RP
4-Way Internal Vent Kit back (standard), left/right/bottom, universal color midnight grey	W10323246	W10323246	W10323246	W10323246	W10323246	W10323246	W10323246
LP Gas Conversion kit	W10307153	W10307153	W10307153	W10307153	W10307153	W10307153	W10307153
4" Gas Dryer Hook-Up kit	20-48KITRC	20-48KITRC	20-48KITRC	20-48KITRC	20-48KITRC	20-48KITRC	20-48KITRC
4', 3-wire, 30 amp dryer cord	PT220L	PT220L	PT220L	PT220L	PT220L	PT220L	PT220L
4', 4-wire, 30 amp dryer cord	PT400L	PT400L	PT400L	PT400L	PT400L	PT400L	PT400L
6', 3-wire, 30 amp dryer cord	PT500L	PT500L	PT500L	PT500L	PT500L	PT500L	PT500L
6', 4-wire, 30 amp dryer cord	PT600L	PT600L	PT600L	PT600L	PT600L	PT600L	PT600L
DIMENSIONS AND COLORS							
Max height (A)	39 3/4"	39 3/4"	39 3/4"	39 3/4"	39 3/4"	39 3/4"	39 3/4"
Width (B)	27"	27"	27"	27"	27"	27"	27"
Depth (C)	33 1/8"	33 1/8"	33 1/8"	33 1/8"	33 1/8"	33 1/8"	33 1/8"
Depth with door open (D)	52 1/4"	52 1/4"	52 1/4"	52 1/4"	52 1/4"	52 1/4"	52 1/4"
Available colors	W	W	W	W C	W C	W C	W C U

Bold type indicates a step-up feature

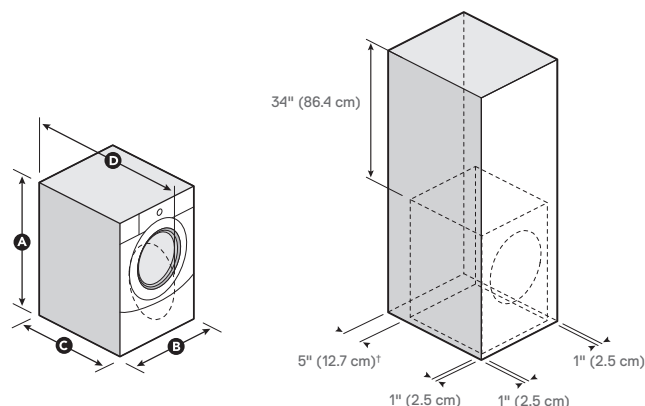

†Add 5-1/2" for proper venting of gas dryers.

DIMENSIONS ARE SHOWN FOR PLANNING PURPOSES ONLY.
For complete information, see Installation Instructions packed with product.

Cabrio® HE Top Load Washers

SPECIFICATIONS AND DIMENSIONS

WASHER MODEL RECOMMENDED DRYER	WHIRLPOOL®	
	WTW5500B WE/GD5500B	WTW5800B WE/GD5800B
New 2013 model	.	.
Capacity (cu. ft.)	3.8	3.8
High-efficiency washer	.	.
ENERGY STAR® qualified	.	.
Meets CEE Tier standards*	Tier 3	Tier 3
Water use/Energy use**	74% less / 81% less	74% less / 81% less
Cycle status bar	.	.
Estimated time remaining LED display	.	◆
Eco Monitor	.	◆
End-of-cycle signal	.	Loud/Soft/Off
Lid	Wide open	EasyView™ framed glass
Smooth Spiral stainless steel wash basket	.	.
Designed, engineered and assembled in the U.S.A.	.	.
WASH SYSTEM		
Adaptive Wash technology	.	.
Adaptive wash actions	5	5
Precision Dispense	.	.
Automatic dispensers	Detergent, bleach, fabric softener	Detergent, bleach, fabric softener
Care Control temperature management system	.	.
Quiet Spin technology	.	.
Quiet Wash noise reduction system	.	.
Max spin speed (RPM)	up to 800	up to 800
Total number of water levels	Auto Load Sensing	Auto Load Sensing
Wash action	Smooth impeller	Smooth impeller
Total number of temperatures	5	5
CYCLES AND OPTIONS		
Total number of cycles	11	13
Quick Wash cycle	.	.
Delicate cycle	.	.
Normal cycle	.	.
Casual cycle	.	.
Cold Wash cycle	.	.
Bulky Items cycle	.	.
Super Wash cycle	.	.
Whites cycle	.	◆
Clean Washer cycle with affresh® Washer cleaner	.	.
Deep Water Wash cycle	.	.
Soak cycle	.	◆
EcoBoost™ option	.	◆
Deep Clean option	.	◆
Delay Wash option	.	up to 9 hours
Extra Rinse option	.	.
Presoak option	.	◆
ACCESSORIES		
5' Washer Inlet Hose kit (2-pack)	8212641RP	8212641RP
5' Nylon Braided Washer Fill Hose kit (2-pack)	8212487RP	8212487RP
6' Gooseneck Nylon Braided Fill Hose kit (2-pack)	8212638RP	8212638RP
10' Washer Inlet Hose kit (2-pack)	8212656RP	8212656RP
Washer drip tray	8212526	8212526
DIMENSIONS AND COLORS		
Max height (A)	43½"	43½"
Width (B)	27½"	27½"
Depth (C)	27"	27"
Height with lid open (D)	53½"	53½"
Top height (E)	36¾"	36¾"
Available colors	W	W C

Bold type indicates a step-up feature

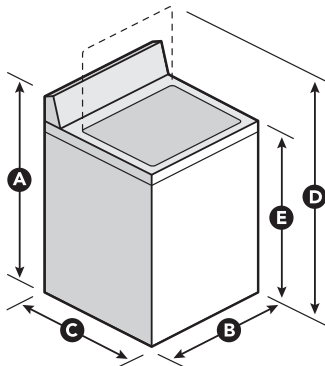

*Based on the Consortium for Energy Efficiency qualifying product lists. Visit cee1.org for more information.
**Compared to pre-2004 traditional top load washers.

DIMENSIONS ARE SHOWN FOR PLANNING PURPOSES ONLY.
For complete information, see Installation Instructions packed with product.

Cabrio® HE Dryers

SPECIFICATIONS AND DIMENSIONS

DRYER MODEL	WHIRLPOOL®	
	WED5500B WGD5500B	WED5800B WGD5800B
RECOMMENDED WASHER	WTW5500B	WTW5800B
New 2013 model	.	.
Capacity (cu. ft.)	7.4	7.4
High-efficiency dryer	.	.
Estimated time remaining LED display	.	♦
Eco Monitor	.	♦
Damp Dry signal	.	♦
End-of-cycle signal	On/Off	Loud/Soft/Off
Drum light	.	On/Off
Door style	Hamper	Hamper with window
Designed, engineered and assembled in the U.S.A.	.	.
DRYING SYSTEM		
AccuDry™ sensor drying system	.	.
Quiet Dry noise reduction system	.	.
Timed dry	.	.
4-way venting	.	.
Total number of temperatures	4	5
CYCLES AND OPTIONS		
Total number of cycles	10	9
Sanitize cycle	.	♦
Quick Dry cycle	.	♦
Delicate cycle	.	♦
Normal cycle	.	.
Eco Normal cycle	.	♦
Casual cycle	.	♦
Less Dry cycle	.	.
Heavy Duty cycle	.	♦
Wrinkle Shield™ option	up to 90 minutes	up to 150 minutes
ACCESSORIES		
Dryer rack	8212450A	8212450A
4-Way Internal Vent Kit Back (standard), left/right/bottom, universal color midnight grey	W10186596	W10186596
LP Gas Conversion kit	W10317689	W10317689
4' Gas Dryer Hook-Up kit	20-48KITRC	20-48KITRC
4', 3-wire, 30 amp dryer cord	PT220L	PT220L
4', 4-wire, 30 amp dryer cord	PT400L	PT400L
6', 3-wire, 30 amp dryer cord	PT500L	PT500L
6', 4-wire, 30 amp dryer cord	PT600L	PT600L
DIMENSIONS AND COLORS		
Max height (A)	43 1/2"	43 1/2"
Width (B)	27"	27"
Depth (C)	29 1/2"	29 1/2"
Depth with door open (D)	43 1/4"	43 1/4"
Top height (E)	36 1/2"	36 1/2"
Available colors	W	W C

Bold type indicates a step-up feature

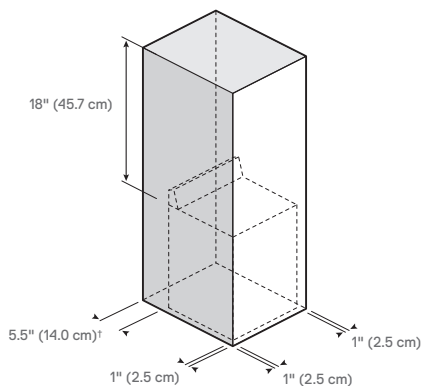
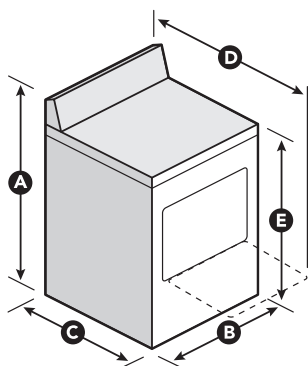

†Add 5-1/2" for proper venting of gas dryers.

DIMENSIONS ARE SHOWN FOR PLANNING PURPOSES ONLY.
For complete information, see Installation Instructions packed with product.

Cabrio® Platinum HE Top Load Washers

SPECIFICATIONS AND DIMENSIONS

WASHER MODEL RECOMMENDED DRYER	WHIRLPOOL®			
	WTW8000B WE/GD8000B	WTW8100B WE/GD8100B	WTW8500B WE/GD8500B	WTW8900B WE/GD8900B
New 2013 model
Capacity (cu. ft.)	4.5	4.5	4.8	4.8
High-efficiency washer
ENERGY STAR® qualified
Meets CEE Tier standards*	Tier 3	Tier 3	Tier 3	Tier 3
Water use/Energy use**	74% less / 82% less	74% less / 82% less	74% less / 82% less	74% less / 82% less
Estimated time remaining LED display
Eco Monitor
End-of-cycle signal	On/Off	On/Off	Loud/Soft/Off	Loud/Soft/Off
Lid	Wide open	EasyView™ framed glass	EasyView™ framed glass	EasyView™ frameless glass with slow-close hinge
Interior LED light	.	.	.	♦
Smooth Spiral stainless steel wash basket
Chrome accents	.	.	.	♦
Designed, engineered and assembled in the U.S.A.
WASH SYSTEM				
Adaptive Wash technology
Adaptive wash actions	11	11	11	11
Precision Dispense	Plus	Plus	Plus	Plus
Automatic dispensers	Detergent, bleach, fabric softener	Detergent, bleach, fabric softener	Detergent, bleach, fabric softener	Detergent, oxi /bleach, fabric softener
Care Control temperature management system
Quiet Spin technology
Quiet Wash noise reduction system	Ultra	Ultra	Ultra	Ultra
Max spin speed (RPM)	up to 1,100	up to 1,100	up to 1,100	up to 1,100
Total number of water levels	Auto Load Sensing	Auto Load Sensing	Auto Load Sensing	Auto Load Sensing
Wash action	Smooth impeller	Smooth impeller	Unique soft-touch impeller	Unique soft-touch impeller
Direct drive motor	♦	.	.	.
Total number of temperatures	4	4	4	5
Water heater	.	.	♦	.
CYCLES AND OPTIONS				
Total number of cycles	11	11	13	16
Quick Wash cycle
Delicate cycle
Active Wear cycle	.	.	♦	.
Sheets cycle	♦	.	.	.
Towels cycle	.	.	.	♦
Casual cycle
Normal cycle
Cold Wash cycle	.	.	♦	.
Bulky Items cycle
Whites cycle
Allergen cycle	.	.	.	♦
Sanitary cycle with Steam and Oxi	.	.	.	♦
Clean Washer cycle with affresh® Washer cleaner
Deep Water Soak cycle	.	.	.	♦
Heavy Duty cycle	♦	.	.	.
Soak cycle	.	.	♦	.
EcoBoost™ option
Deep Clean option	.	.	.	with Heater
Oxi Dispense option	.	.	.	♦
Delay Wash option	up to 8 hours	up to 10 hours	up to 12 hours	up to 12 hours
Extra rinse option
ACCESSORIES				
5' Washer Inlet Hose kit (2-pack)	8212641RP	8212641RP	8212641RP	8212641RP
5' Nylon Braided Washer Fill Hose kit (2-pack)	8212487RP	8212487RP	8212487RP	8212487RP
6' Gooseneck Nylon Braided Fill Hose kit (2-pack)	8212638RP	8212638RP	8212638RP	8212638RP
10' Washer Inlet Hose kit (2-pack)	8212656RP	8212656RP	8212656RP	8212656RP
Washer drip tray	8212526	8212526	8212526	8212526
DIMENSIONS AND COLORS				
Max height (A)	44"	44"	45½"	45½"
Width (B)	27⅝"	27⅝"	27⅝"	27⅝"
Depth (C)	27⅝"	27⅝"	27⅝"	27⅝"
Height with lid open (D)	58"	58"	58½"	58½"
Top height (E)	39"	39"	39½"	39½"
Available colors	W	W	W C	W C

Bold type indicates a step-up feature

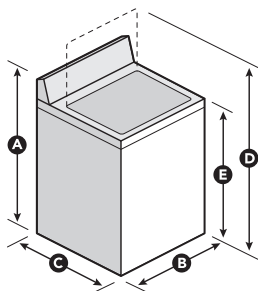

*Based on the Consortium for Energy Efficiency qualifying product lists. Visit cee1.org for more information.
**Compared to pre-2004 traditional top load washers.

DIMENSIONS ARE SHOWN FOR PLANNING PURPOSES ONLY.
For complete information, see Installation Instructions packed with product.

Cabrio® Platinum HE Dryers

SPECIFICATIONS AND DIMENSIONS

	WHIRLPOOL®			
DRYER MODEL	WED8000B WGD8000B	WED8100B WGD8100B	WED8500B WGD8500B	WED8900B WGD8900B
RECOMMENDED WASHER	WTW8000B	WTW8100B	WTW8500B	WTW8900B
New 2013 model
Capacity (cu. ft.)	7.6	7.6	7.6	7.6
High-efficiency dryer
Estimated time remaining LED display
Eco Monitor
Damp Dry signal	On/Off	On/Off	On/Off	On/Off
End-of-cycle signal	On/Off	On/Off	Loud/Soft/Off	Loud/Soft/Off
Check vent indicator	♦	.	.	.
Drum light
Door style	Reversible side-swing	Reversible side-swing with window	Reversible side-swing with window	Reversible side-swing with window
Chrome accents	.	.	.	♦
Designed, engineered and assembled in the U.S.A.
DRYING SYSTEM				
Advanced Moisture Sensing	♦	.	.	.
Quiet Dry Ultra noise reduction system	♦	.	.	.
Venting options	2-way	2-way	2-way	2-way
Dual heating element	♦	.	.	.
Y connector	.	.	♦	.
Timed dry
Total number of temperatures	5	5	5	5
CYCLES AND OPTIONS				
Total number of cycles	9	9	11	14
Steam-enhanced cycles	.	.	♦	.
Sanitize cycle
Quick Dry cycle
Quick Refresh Steam cycle	.	.	.	♦
Enhanced Touch Up Steam cycle	.	.	♦	.
Delicate cycle
Active Wear cycle	.	.	♦	.
Sheets cycle	.	.	♦	.
Bulky Items cycle	♦	.	.	.
Casual cycle
Normal cycle
Towels cycle	.	.	.	♦
Jeans cycle	.	.	.	♦
Heavy Duty cycle
EcoBoost™ option
Wrinkle Shield™ Plus option	.	.	.	up to 150 minutes with Steam
Wrinkle Shield™ option	up to 150 minutes	up to 150 minutes	up to 150 minutes	.
Static Reduce option	.	.	.	♦
ACCESSORIES				
Dryer rack	8577312A	8577312A	8577312A	8577312A
LP Gas Conversion kit	W10317689	W10317689	W10317689	W10317689
4' Gas Dryer Hook-Up kit	20-48KITRC	20-48KITRC	20-48KITRC	20-48KITRC
4', 3-wire, 30 amp dryer cord	PT220L	PT220L	PT220L	PT220L
4', 4-wire, 30 amp dryer cord	PT400L	PT400L	PT400L	PT400L
6', 3-wire, 30 amp dryer cord	PT500L	PT500L	PT500L	PT500L
6', 4-wire, 30 amp dryer cord	PT600L	PT600L	PT600L	PT600L
DIMENSIONS AND COLORS				
Max height (A)	44"	44"	45½"	45½"
Width (B)	29"	29"	29"	29"
Depth (C)	29¼"	29¼"	29¼"	29¼"
Depth with door open (D)	52¾"	52¾"	52¾"	52¾"
Top height (E)	39"	39"	39½"	39½"
Available colors	W	W	W C	W C

Bold type indicates a step-up feature

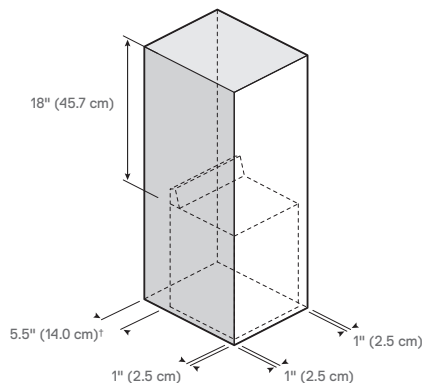
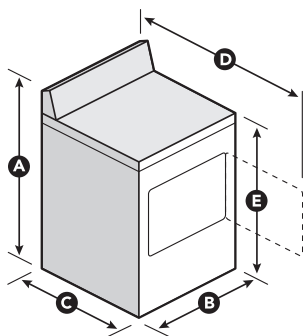

†Add 5-1/2" for proper venting of gas dryers.

DIMENSIONS ARE SHOWN FOR PLANNING PURPOSES ONLY.
For complete information, see Installation Instructions packed with product.

Traditional Top Load Washers

SPECIFICATIONS AND DIMENSIONS

WASHER MODEL	WHIRLPOOL®		
	WTW4800B	WTW4850B WE/GD4850B WE/GD4890B	WTW4900B WE/GD4850B WE/GD4890B
RECOMMENDED DRYERS	WE/GD4800B		
New 2013 model	.	.	.
Capacity (cu. ft.)	3.6	3.6	3.8
High-efficiency washer	.	.	♦
ENERGY STAR® qualified	.	♦	.
Meets CEE Tier standards*	.	.	Tier 3
Water use/Energy use**	.	60% less / 77% less	74% less / 81% less
Cycle status bar	.	.	.
Wide open lid	.	.	.
Wash basket	White porcelain	White porcelain	Smooth Spiral stainless steel
Designed, engineered and assembled in the U.S.A.	.	.	.
WASH SYSTEM			
Fabric Sense™ wash system	.	.	.
Adaptive wash actions	.	.	5
Additive dispensers	Bleach, fabric softener	Bleach, fabric softener	Bleach
Care Control temperature management system	.	.	.
Quiet Spin technology	.	.	.
Max spin speed (RPM)	up to 700	up to 800	up to 800
Total number of water levels	4	Auto Load Sensing	Auto Load Sensing
Wash action	Smooth motion agitator	Smooth motion agitator	Smooth impeller
Total number of temperatures	5	5	5
CYCLES AND OPTIONS			
Total number of cycles	9	12	12
Quick Wash cycle	.	♦	.
Delicate cycle	.	.	.
Casual cycle	.	.	.
Cold Wash cycle	.	♦	.
Normal cycle	.	.	.
Deep Water Wash cycle	.	♦	.
Bulky Items/Sheets cycle	.	♦	.
Clean Washer cycle with affresh® Washer cleaner	.	.	.
Heavy Duty cycle	.	♦	.
Soak cycle	.	♦	.
Extra Rinse option	.	.	.
Extra Large Load Size option	.	.	.
Presoak option	.	♦	.
ACCESSORIES			
5' Washer Inlet Hose kit (2-pack)	8212641RP	8212641RP	8212641RP
5' Nylon Braided Washer Fill Hose kit (2-pack)	8212487RP	8212487RP	8212487RP
6' Gooseneck Nylon Braided Fill Hose kit (2-pack)	8212638RP	8212638RP	8212638RP
10' Washer Inlet Hose kit (2-pack)	8212656RP	8212656RP	8212656RP
Washer drip tray	8212526	8212526	8212526
DIMENSIONS AND COLORS			
Max height (A)	43"	43"	43"
Width (B)	27½"	27½"	27½"
Depth (C)	27"	27"	27"
Height with door open (D)	53"	53"	53"
Top height (E)	36"	36"	36"
Available colors	Q	W	W

Bold type indicates a step-up feature

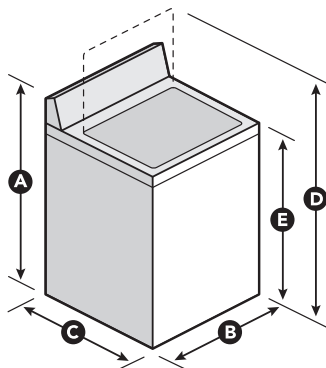

*Based on the Consortium for Energy Efficiency qualifying product lists. Visit cee1.org for more information.
**Compared to pre-2004 traditional top load washers.

DIMENSIONS ARE SHOWN FOR PLANNING PURPOSES ONLY.
For complete information, see Installation Instructions packed with product.

Traditional Dryers

SPECIFICATIONS AND DIMENSIONS

DRYER MODEL	WHIRLPOOL®		
	WED4800B WGD4800B	WED4850B WGD4850B	WED4890B WGD4890B
RECOMMENDED WASHERS	WTW4800B	WTW4850B WTW4900B	WTW4850B WTW4900B
New 2013 model	-	-	-
Capacity (cu. ft.)	7.0	7.0	6.4
High-efficiency dryer	-	♦	-
On/Off end-of-cycle signal	-	-	-
Drum light	-	♦	-
Door style	Reversible side-swing	Wide-opening hamper	Reversible side-swing
Smooth, flat back design	-	-	♦
Designed, engineered and assembled in the U.S.A.	-	-	-
DRYING SYSTEM			
AccuDry™ sensor drying system	-	♦	-
AutoDry™ drying system	-	-	-
Timed Dry	-	-	-
Total number of temperatures	5	5	5
CYCLES AND OPTIONS			
Total number of cycles	15	12	12
Very Dry cycle	-	-	-
Delicate cycle	-	♦	-
Jeans cycle	-	♦	-
Less Dry cycle	-	-	-
Energy Preferred cycles	-	-	-
Heavy Dry cycle	-	-	-
Wrinkle Shield™ option	up to 40 minutes	up to 90 minutes	up to 90 minutes
ACCESSORIES			
Dryer rack	3406839	3406839	-
LP Gas Conversion kit	49572	49572	49572
4' Gas Dryer Hook-Up kit	20-48KITRC	20-48KITRC	20-48KITRC
4', 3-wire, 30 amp dryer cord	PT220L	PT220L	PT220L
4', 4-wire, 30 amp dryer cord	PT400L	PT400L	PT400L
6', 3-wire, 30 amp dryer cord	PT500L	PT500L	PT500L
6', 4-wire, 30 amp dryer cord	PT600L	PT600L	PT600L
DIMENSIONS AND COLORS			
Max height (A)	43"	43"	43"
Width (B)	29"	29"	29"
Depth (C)	29½"	29½"	25½"
Depth with door open (D)	50½"	42"	50½"
Top height (E)	36"	36"	36"
Available colors	Q	W	W

Bold type indicates a step-up feature

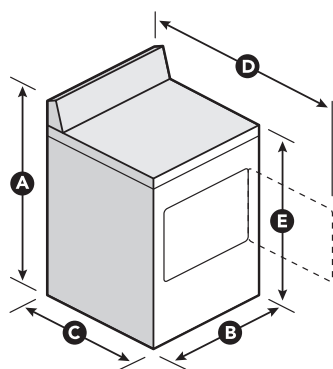

Reversible side-swing door

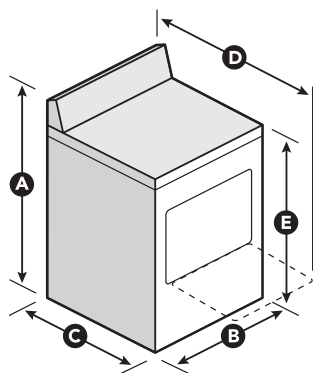

Wide-opening hamper door

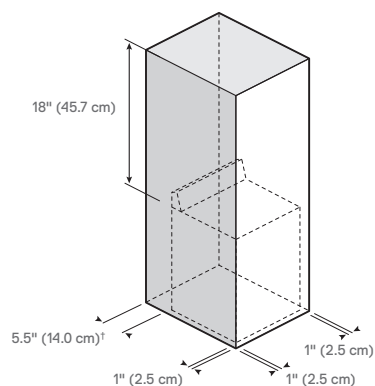

†Add 5-1/2" for proper venting of gas dryers.

DIMENSIONS ARE SHOWN FOR PLANNING PURPOSES ONLY.
For complete information, see Installation Instructions packed with product.

Thin Twin® Laundry Centers

SPECIFICATIONS AND DIMENSIONS

	WHIRLPOOL®	
MODEL	LTE/G5243D	WE/GT3300X
Washer capacity (cu. ft.)	1.5	2.5
Thin Twin® Laundry Center	.	.
Tough Top™ II top and lid	.	.
Wash basket	Spreckle	White porcelain
Designed, engineered and assembled in the U.S.A.	.	.
WASH SYSTEM		
Additive dispensers		Bleach, fabric softener
Selectable water levels	3	3
Wash action	Surgilator® agitator	Two-piece Surgilator® agitator
Total number of temperatures	4	4
WASH CYCLES		
Total number of cycles	5	8
Delicate cycle	.	.
Prewash cycle	.	.
Super Wash cycle	.	.
DRYER FEATURES		
Dryer capacity (cu. ft.)	3.4	5.9
Total number of cycles	18	6
Total number of temperatures	4	3
Timed drying	.	.
Automatic Dry	.	.
Tumble Press® cycle	.	.
2-way venting	.	.
End-of cycle signal	.	.
ACCESSORIES		
Dryer rack	N/A	N/A
LP Gas Conversion kit	49573	3392235
24"/27" Thin Twin® (stacked LDY) side exhaust vent extension kit	279823	279823
4" Gas Dryer Hook-Up kit	20-48KITRC	20-48KITRC
4', 3-wire, 30 amp dryer cord	PT220L	PT220L
4', 4-wire, 30 amp dryer cord	PT400L	PT400L
6', 3-wire, 30 amp dryer cord	PT500L	PT500L
6', 4-wire, 30 amp dryer cord	PT600L	PT600L
DIMENSIONS AND COLORS		
Max height (A)	71¾"	71⅝"
Width (B)	24"	27"
Depth (C)	27¼"	32"
Available colors	Q	Q

Bold type indicates a step-up feature

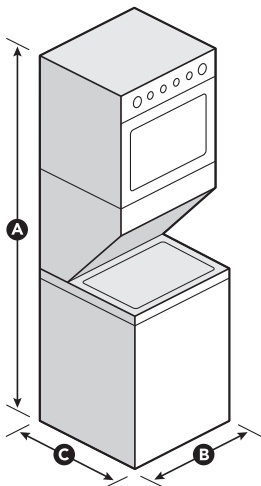

DIMENSIONS ARE SHOWN FOR PLANNING PURPOSES ONLY.
For complete information, see Installation Instructions packed with product.

Compact Laundry Pairs

SPECIFICATIONS AND DIMENSIONS

WASHER MODEL		WHIRLPOOL®
WFC7500V		
Washer capacity (cu. ft.)		2.0
Washer configuration		Front load
ENERGY STAR® qualified		-
Meets CEE Tier standards*		Tier 1
Estimated time remaining display		-
Cycle status bar		-
Lighted cycle indicators		-
Wash basket		Stainless steel
WASH SYSTEM		
Gentle wash system		-
Additive dispensers		Detergent, bleach, fabric softener
Noise reduction system		Quiet Wash
Max spin speed (RPM)		up to 1,200
Automatic water level control		-
Total number of temperatures		3
CYCLES AND OPTIONS		
Total number of cycles		8
Heavy Duty cycle		-
Quick Wash cycle		-
Clean Washer cycle		-
Delicate cycle		-
Prewash option		-
Delay Wash option		up to 12 hours
Extra Rinse option		-
DIMENSIONS AND COLORS		
Max height (A)		32 ¹⁵ / ₁₆ "
Width (B)		23 ⁷ / ₈ "
Depth (C)		23 ¹ / ₈ "
Depth with door open (D)		36 ¹ / ₄ "
Available colors		W
DRYER MODEL		WED7500V
Capacity (cu. ft.)		3.8
Drum material		Stainless steel
End-of-cycle signal		-
Door window		-
Side-swing door		-
DRYING SYSTEM		
AutoDry™ drying system		-
Moisture sensor control		-
Long vent exhaust		-
Total number of temperatures		2
Power source		240 Volt
CYCLES AND OPTIONS		
Total number of cycles		11
Damp Dry cycle		-
Normal cycle		-
ACCESSORIES		
Dryer stack kit		Included
Compact Dryer Stand kit		N/A
4', 3-wire, 30 amp dryer cord		PT220L
4', 4-wire, 30 amp dryer cord		PT400L
6', 3-wire, 30 amp dryer cord		PT500L
6', 4-wire, 30 amp dryer cord		PT600L
DIMENSIONS AND COLORS		
Max height (A)		33 ¹ / ₄ "
Width (B)		23 ⁷ / ₈ "
Depth (C)		23 ¹ / ₄ "
Depth with door open (D)		39"
Available colors		W

Bold type indicates a step-up feature

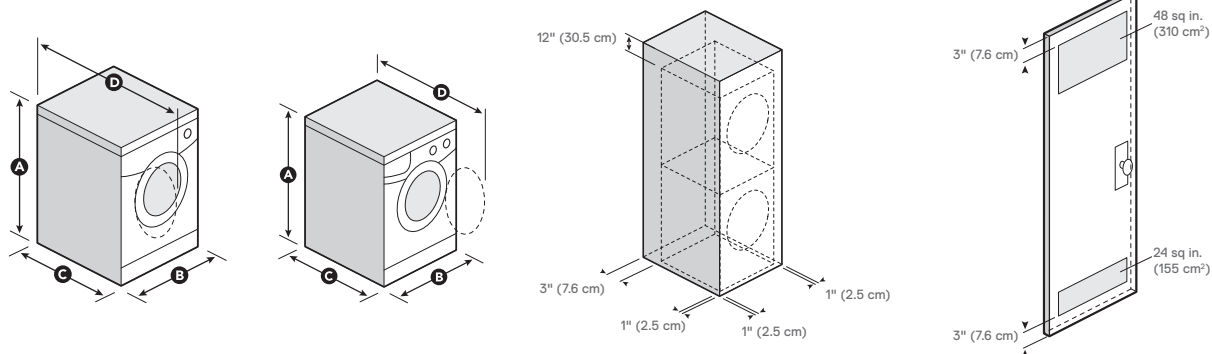

*Based on the Consortium for Energy Efficiency qualifying product lists. Visit cee1.org for more information.

DIMENSIONS ARE SHOWN FOR PLANNING PURPOSES ONLY.
For complete information, see Installation Instructions packed with product.

Compact Laundry Pairs

SPECIFICATIONS AND DIMENSIONS

WASHER MODEL	WHIRLPOOL® LCE4332P
Washer capacity (cu. ft.)	2.1
Washer configuration	Top load
Lighted cycle indicators	-
Wash basket	Stainless steel
WASH SYSTEM	
Gentle wash system	-
Additive dispensers	Detergent, bleach, fabric softener
Wash speeds	3
Selectable water levels	2
Straight vane agitator	-
Total number of temperatures	3
CYCLES AND OPTIONS	
Total number of cycles	4
Heavy Duty cycle	-
Quick Wash cycle	-
Delicate cycle	-
DIMENSIONS AND COLORS	
Max height (A)	35"
Width (B)	22½"
Depth (C)	24"
Height with door open (D)	49¼"
Available colors	Q

DRYER MODEL	LER3622P	LDR3822P
Capacity (cu. ft.)	3.4	3.4
Drum material	DuraWhite™	DuraWhite™
End-of-cycle signal	-	-
Side-swing door	-	-
Designed, engineered and assembled in the U.S.A.	-	-
DRYING SYSTEM		
AccuDry™ sensor drying system	-	◆
Gentle heat system	-	-
Total number of temperatures	2	2
Power source	240 Volt	120 Volt
CYCLES AND OPTIONS		
Total number of cycles	3	3
ACCESSORIES		
Dryer rack	N/A	N/A
Compact Dryer Stand kit	49971	49971
4', 3-wire, 30 amp dryer cord	PT220L	PT220L
4', 4-wire, 30 amp dryer cord	PT400L	PT400L
6', 3-wire, 30 amp dryer cord	PT500L	PT500L
6', 4-wire, 30 amp dryer cord	PT600L	PT600L
DIMENSIONS AND COLORS		
Max height (A)	31"	31"
Width (B)	23⅞"	24"
Depth (C)	21⅝"	21⅝"
Depth with door open (D)	37⅝"	37⅝"
Available colors	Q	Q

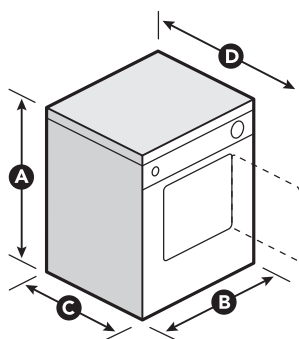
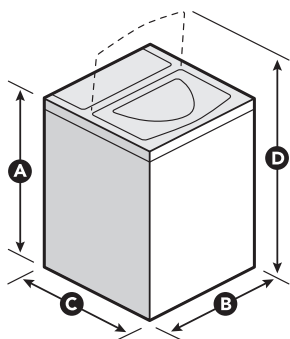

DIMENSIONS ARE SHOWN FOR PLANNING PURPOSES ONLY.
For complete information, see Installation Instructions packed with product.

Laundry 1-2-3™ Pedestals

SPECIFICATIONS AND DIMENSIONS

MODEL	LAB0050P	XHP1000X	XHPC155X	XHPC155Y
Storage drawer			♦	•
Duet® pair compatible		♦	•	•
Chrome handle			♦	•
Designed, engineered and assembled in the U.S.A.	•	•	•	•
DIMENSIONS AND COLORS				
Height	11.8"	10"	15.5"	15.5"
Width	23.4"	27"	27"	27"
Depth	20.1"	26.8"	27.3"	27.3"
Available colors	Q	W	W	C U

Bold type indicates a step-up feature

Whirlpool brand is constantly improving and innovating our products, so the specifications and dimensions in this catalog are subject to change without notice.

DIMENSIONS ARE SHOWN FOR PLANNING PURPOSES ONLY.
For complete information, see Installation Instructions packed with product.



Whirlpool Corporation donates a range and an ENERGY STAR® qualified refrigerator to every new Habitat for Humanity home built in North America.



With 20,000 workers throughout the country, America is home to Whirlpool Corporation as it delivers world-class appliances and exceptional service.



**American
Pride**

Designed, engineered and
assembled in the U.S.A.

Designed to Simplify™  Whirlpool®